

**Draft Recommendation for  
Space Data System Standards**

**PROXIMITY-1 SPACE LINK  
PROTOCOL—CODING AND  
SYNCHRONIZATION  
SUBLAYER**

**DRAFT RECOMMENDED STANDARD**

**CCSDS 211.2-P-3.2**

**PINK BOOK**  
**April 2026**

**Recommendation for Space Data System Standards**

**PROXIMITY-1 SPACE LINK  
PROTOCOL—CODING AND  
SYNCHRONIZATION  
SUBLAYER**

**RECOMMENDED STANDARD**

**CCSDS 211.2-P-3.2**

**PINK BOOK**

**April 2026**

## AUTHORITY

Issue:	Draft Recommended Standard, Issue 3
Date:	January 2026
Location:	Washington, DC, USA

This document has been approved for publication by the Management Council of the Consultative Committee for Space Data Systems (CCSDS) and represents the consensus technical agreement of the participating CCSDS Member Agencies. The procedure for review and authorization of CCSDS documents is detailed in *Organization and Processes for the Consultative Committee for Space Data Systems* (CCSDS A02.1-Y-4), and the record of Agency participation in the authorization of this document can be obtained from the CCSDS Secretariat at the e-mail address below.

This document is published and maintained by:

CCSDS Secretariat  
National Aeronautics and Space Administration  
Washington, DC, USA  
Email: [secretariat@mailman.ccsds.org](mailto:secretariat@mailman.ccsds.org)

## STATEMENT OF INTENT

The Consultative Committee for Space Data Systems (CCSDS) is an organization officially established by the management of its members. The Committee meets periodically to address data systems problems that are common to all participants, and to formulate sound technical solutions to these problems. Inasmuch as participation in the CCSDS is completely voluntary, the results of Committee actions are termed **Recommended Standards** and are not considered binding on any Agency.

This **Recommended Standard** is issued by, and represents the consensus of, the CCSDS members. Endorsement of this **Recommendation** is entirely voluntary. Endorsement, however, indicates the following understandings:

- o Whenever a member establishes a CCSDS-related **standard**, this **standard** will be in accord with the relevant **Recommended Standard**. Establishing such a **standard** does not preclude other provisions which a member may develop.
- o Whenever a member establishes a CCSDS-related **standard**, that member will provide other CCSDS members with the following information:
  - The **standard** itself.
  - The anticipated date of initial operational capability.
  - The anticipated duration of operational service.
- o Specific service arrangements shall be made via memoranda of agreement. Neither this **Recommended Standard** nor any ensuing **standard** is a substitute for a memorandum of agreement.

No later than five years from its date of issuance, this **Recommended Standard** will be reviewed by the CCSDS to determine whether it should: (1) remain in effect without change; (2) be changed to reflect the impact of new technologies, new requirements, or new directions; or (3) be retired or canceled.

In those instances when a new version of a **Recommended Standard** is issued, existing CCSDS-related member standards and implementations are not negated or deemed to be non-CCSDS compatible. It is the responsibility of each member to determine when such standards or implementations are to be modified. Each member is, however, strongly encouraged to direct planning for its new standards and implementations towards the later version of the Recommended Standard.

## FOREWORD

Attention is drawn to the possibility that some of the elements of this document may be the subject of patent rights. CCSDS has processes for identifying patent issues and for securing from the patent holder agreement that all licensing policies are reasonable and non-discriminatory. However, CCSDS does not have a patent law staff, and CCSDS shall not be held responsible for identifying any or all such patent rights.

Through the process of normal evolution, it is expected that expansion, deletion, or modification of this document may occur. This Recommended Standard is therefore subject to CCSDS document management and change control procedures, which are defined in *Organization and Processes for the Consultative Committee for Space Data Systems* (CCSDS A02.1-Y-4). Current versions of CCSDS documents are maintained at the CCSDS Web site:

<http://www.ccsds.org/>

Questions relating to the contents or status of this document should be sent to the CCSDS Secretariat at the email address indicated on page i.

## DOCUMENT CONTROL

<b>Document</b>	<b>Title</b>	<b>Date</b>	<b>Status</b>
CCSDS 211.0-B-1	Proximity-1 Space Link Protocol	October 2002	Original issue, superseded
CCSDS 211.2-B-1	Proximity-1 Space Link Protocol— Coding and Synchronization Sublayer	April 2003	Superseded
CCSDS 211.2-B-2	Proximity-1 Space Link Protocol— Coding and Synchronization Sublayer, Recommended Standard, Issue 2	December 2013	Issue 2, superseded
CCSDS 211.2-B-3	Proximity-1 Space Link Protocol— Coding and Synchronization Sublayer, Recommended Standard, Issue 3	October 2019	Issue 3, superseded: Updates specification to include applicability to Unified Space Data Link Protocol, CCSDS 732.1-B-1.
CCSDS 211.2-B-4	Proximity-1 Space Link Protocol— Coding and Synchronization Sublayer, Recommended Standard, Issue 4	July 2025	Current issue:  New LDPC coding options

## CONTENTS

<u>Section</u>	<u>Page</u>
<b>1 INTRODUCTION.....</b>	<b>1-1</b>
1.1 PURPOSE.....	1-1
1.2 SCOPE.....	1-1
1.3 APPLICABILITY.....	1-1
1.4 RATIONALE.....	1-2
1.5 DOCUMENT STRUCTURE .....	1-2
1.6 CONVENTIONS AND DEFINITIONS .....	1-3
1.7 REFERENCES .....	1-6
<b>2 OVERVIEW.....</b>	<b>2-1</b>
2.1 LAYERS OF THE PROTOCOL.....	2-1
2.2 PHYSICAL LAYER.....	2-1
2.3 DATA LINK LAYER .....	2-2
2.4 CODING AND SYNCHRONIZATION SUBLAYER.....	2-2
<b>3 CODING AND SYNCHRONIZATION SUBLAYER .....</b>	<b>3-1</b>
3.1 OVERVIEW .....	3-1
3.2 PROXIMITY LINK TRANSMISSION UNIT.....	3-1
3.3 IDLE DATA .....	3-3
3.4 CHANNEL CODING.....	3-6
3.5 SEND SIDE PROCEDURES IN THE C&S SUBLAYER.....	3-13
3.6 RECEIVE SIDE PROCEDURES IN THE C&S SUBLAYER.....	3-14
<b>ANNEX A PROTOCOL IMPLEMENTATION CONFORMANCE</b>	
<b>STATEMENT PROFORMA (NORMATIVE).....</b>	<b>A-1</b>
<b>ANNEX B SERVICE (NORMATIVE).....</b>	<b>B-1</b>
<b>ANNEX C CRC-32 CODING PROCEDURES (NORMATIVE) .....</b>	<b>C-1</b>
<b>ANNEX D SECURITY, SANA, AND PATENT CONSIDERATIONS</b>	
<b>(INFORMATIVE) .....</b>	<b>D-6</b>
<b>ANNEX E INFORMATIVE REFERENCES (INFORMATIVE) .....</b>	<b>E-1</b>
<b>ANNEX F ABBREVIATIONS AND ACRONYMS (INFORMATIVE).....</b>	<b>F-1</b>

Figure

1-1 BIT NUMBERING CONVENTION.....	1-5
1-2 PROXIMITY-1 RATE TERMINOLOGY .....	1-5
2-1 SIMPLIFIED OVERVIEW OF PROXIMITY-1 LAYERS.....	2-1
2-2 CODING & SYNCHRONIZATION SUBLAYER SEND SIDE INTERACTIONS .....	2-4

CCSDS RECOMMENDED STANDARD FOR PROXIMITY-1 SPACE LINK PROTOCOL—  
CODING AND SYNCHRONIZATION SUBLAYER

3-1	PROXIMITY-1 LINK TRANSMISSION UNIT (PLTU).....	3-2
3-2	BEHAVIOR OF THE C&S SUBLAYER.....	3-7
3-3	LDPC CODING PROCEDURE.....	3-11
3-4	PSEUDO-RANDOMIZER LOGIC DIAGRAM.....	3-13
C-1	A POSSIBLE IMPLEMENTATION OF THE ENCODER.....	<b>ERROR!</b>
	<b>BOOKMARK NOT DEFINED.</b>	
C-2	A POSSIBLE IMPLEMENTATION OF THE DECODER.....	C-5

## 1 INTRODUCTION

### 1.1 PURPOSE

The purpose of this Recommended Standard is to specify synchronization and channel coding schemes used with the Proximity-1 Data Link Protocol (reference [3]) and Physical Layer (reference [4]). Proximity space links are defined to be short-range, bi-directional, fixed or mobile radio links, generally used to communicate among probes, landers, rovers, orbiting constellations, and orbiting relays. These links are characterized by short time delays, moderate (not weak) signals, and short, independent sessions.

### 1.2 SCOPE

This Recommended Standard defines synchronization and channel coding schemes for Proximity-1 links in terms of

- a) the services provided to the users of this specification;
- b) data formats; and
- c) the procedures performed to generate and process the data formats.

It does not specify

- a) individual implementations or products;
- b) the methods or technologies required to perform the procedures; or
- c) the management activities required to configure and control the protocol.

The Coding and Synchronization Sublayer is part of the Data Link Layer. The rest of the Data Link Layer is defined in the separate CCSDS Recommended Standard entitled, *Proximity-1 Space Link Protocol—Data Link Layer* (reference [3]). The Physical Layer is defined in the separate CCSDS Recommended Standard entitled, *Proximity-1 Space Link Protocol—Physical Layer* (reference [4]).

### 1.3 APPLICABILITY

This Recommended Standard applies to the creation of Agency standards and to future data communications over space links between CCSDS Agencies in cross-support situations. It also applies to internal Agency links for which no cross-support is required. It includes specification of the services and protocols for inter-Agency cross support. It is neither a specification of, nor a design for, systems that may be implemented for existing or future missions.

The Recommended Standard specified in this document is to be invoked through the normal standards programs of each CCSDS Agency and is applicable to those missions for which cross support based on capabilities described in this Recommended Standard is anticipated. Where mandatory capabilities are clearly indicated in sections of the Recommended Standard, they must be implemented when this document is used as a basis for cross support. Where options are allowed or implied, implementation of these options is subject to specific bilateral cross support agreements between the Agencies involved.

## 1.4 RATIONALE

The CCSDS believes it is important to document the rationale underlying the recommendations chosen, so that future evaluations of proposed changes or improvements will not lose sight of previous decisions. The concept and rationale behind the decisions that formed the basis for Proximity-1 is documented in the CCSDS Proximity-1 Space Link Green Book (reference [E1]).

## 1.5 DOCUMENT STRUCTURE

This document is divided into three numbered sections and four annexes:

- a) section 1 presents the purpose, scope, applicability, and rationale of this Recommended Standard and lists the conventions, definitions, and references used throughout the document;
- b) section 2 provides an overview of Proximity-1 synchronization and channel coding;
- c) section 3 specifies convolutional coding;
- d) annex A contains the Protocol Implementation Conformance Statement (PICS) proforma for this specification;
- e) annex B defines the service provided to the users;
- f) annex C defines CRC-32 Coding Procedure;
- g) annex D discusses security, SANA, and patent considerations;
- h) annex E contains informative references;
- i) annex F contains a list of abbreviations and acronyms.

## 1.6 CONVENTIONS AND DEFINITIONS

### 1.6.1 DEFINITIONS

#### 1.6.1.1 Terms from the Open Systems Interconnection Basic Reference Model

This Recommended Standard makes use of a number of terms defined in reference [1]. In this Recommended Standard, those terms are used in a generic sense, that is, in the sense that those terms are generally applicable to any of a variety of technologies that provide for the exchange of information between real systems. Those terms are as follows:

- a) Data Link Layer;
- b) Physical Layer;
- c) protocol data unit;
- d) real system;
- e) service;
- f) service data unit.

#### 1.6.1.2 Terms Defined in This Recommended Standard

For the purposes of this Recommended Standard, the following definitions also apply. Many other terms that pertain to specific items are defined in the appropriate sections.

**forward link:** That portion of a Proximity space link in which the caller transmits and the responder receives (typically a command link).

**physical channel:** The RF channel upon which the stream of channel symbols is transferred over a space link in a single direction.

**Proximity Link Transmission Unit, PLTU:** Data unit composed of the Attached Synchronization Marker, the Transfer Frame, and the attached Cyclic Redundancy Check (CRC)-32.

**Proximity link:** A full-duplex, half-duplex, or simplex link for the transfer of data between Proximity-1 entities in a session.

**return link:** That portion of a Proximity space link in which the responder transmits and the caller receives (typically a telemetry link).

**space link:** A communications link between transmitting and receiving entities, at least one of which is in space.

**Transfer Frame:** The protocol data unit of the protocol sublayer of the Data Link Layer.

NOTE – In this document, ‘Transfer Frame’ refers exclusively to either a Version-3 (Proximity-1) or a Version-4 (USLP) Transfer Frame.

## 1.6.2 NOMENCLATURE

### 1.6.2.1 NORMATIVE TEXT

The following conventions apply for the normative specifications in this Recommended Standard:

- a) the words ‘shall’ and ‘must’ imply a binding and verifiable specification;
- b) the word ‘should’ implies an optional, but desirable, specification;
- c) the word ‘may’ implies an optional specification;
- d) the words ‘is’, ‘are’, and ‘will’ imply statements of fact.

NOTE – These conventions do not imply constraints on diction in text that is clearly informative in nature.

### 1.6.2.2 INFORMATIVE TEXT

In the normative section of this document (section 3 and annexes B and C), informative text is set off from the normative specifications either in notes or under one of the following subsection headings:

- Overview;
- Background;
- Rationale;
- Discussion.

## 1.6.3 CONVENTIONS

In this document, the following convention is used to identify each bit in an  $N$ -bit field. The first bit in the field to be transmitted (i.e., the most left justified when drawing a figure) is defined to be ‘Bit 0’, the following bit is defined to be ‘Bit 1’, and so on up to ‘Bit  $N-1$ ’. When the field is used to express a binary value (such as a counter), the Most Significant Bit (MSB) shall be the first transmitted bit of the field, that is, ‘Bit 0’, as shown in figure 1-1.

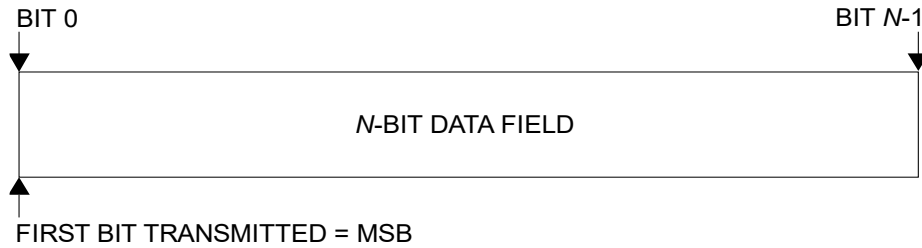

**Figure 1-1: Bit Numbering Convention**

In accordance with standard data-communications practice, data fields are often grouped into eight-bit ‘words’ that conform to the above convention. Throughout this Recommended Standard, such an eight-bit word is called an ‘octet’. The numbering for octets within a data structure begins with zero. Octet zero is the first octet to be transmitted.

Throughout this Recommended Standard, directive, parameter, variable, and signal names are presented with all upper-case characters; data-field and MIB-parameter names are presented with initial capitalization; values and state names are presented with predominantly lower-case characters and are italicized.

In Proximity-1, data rate ( $R_d$ ), coded symbol rate ( $R_{cs}$ ) and channel symbol rate ( $R_{chs}$ ) are used to denote respectively:

- the data rate of the bitstream composed by PLTUs and Idle data measured at the encoder input;
- the coded data rate measured at the interface between the Coding and Synchronization Sublayer and the Physical Layer, and
- the rate measured at the output of the transmitter.

The terms are used as shown in figure 1-2.

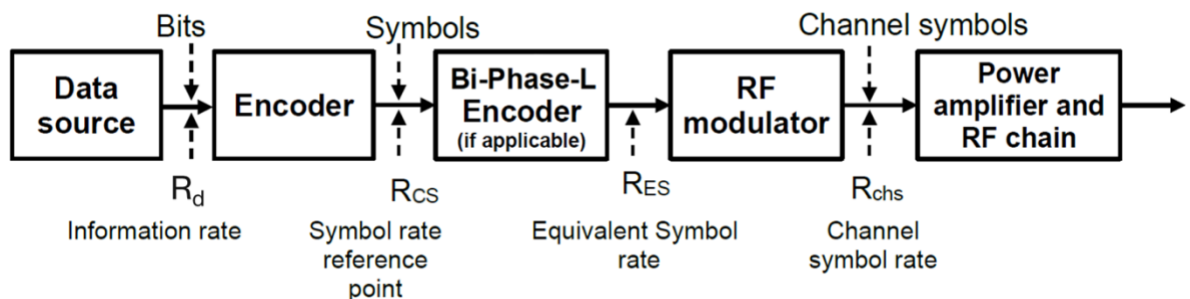

**Figure 1-2: Proximity-1 Rate Terminology**

## 1.7 REFERENCES

The following publications contain provisions which, through reference in this text, constitute provisions of this document. At the time of publication, the editions indicated were valid. All publications are subject to revision, and users of this document are encouraged to investigate the possibility of applying the most recent editions of the publications indicated below. The CCSDS Secretariat maintains a register of currently valid CCSDS publications.

- [1] *Information Technology—Open Systems Interconnection—Basic Reference Model: The Basic Model*. 2nd ed. International Standard, ISO/IEC 7498-1:1994. Geneva: ISO, 1994.
- [2] *TM Synchronization and Channel Coding*. Issue 6. Recommendation for Space Data System Standards (Blue Book), CCSDS 131.0-B-6. Washington, D.C.: CCSDS, Forthcoming.
- [3] *Proximity-1 Space Link Protocol—Data Link Layer*. Issue 7. Recommendation for Space Data System Standards (Blue Book), CCSDS 211.0-B-7. Washington, D.C.: CCSDS, Forthcoming.
- [4] *Proximity-1 Space Link Protocol—Physical Layer*. Issue 5. Recommendation for Space Data System Standards (Blue Book), CCSDS 211.1-B-5. Washington, D.C.: CCSDS, Forthcoming.
- [5] *Unified Space Data Link Protocol*. Issue 3. Recommendation for Space Data System Standards (Blue Book), CCSDS 732.1-B-3. Washington, D.C.: CCSDS, June 2024.
- [6] *Space Communications Session Control*. Issue 1. Recommendation for Space Data System Standards (Blue Book), CCSDS 235.1-B-1. Washington, D.C.: CCSDS, Forthcoming.

## 2 OVERVIEW

### 2.1 LAYERS OF THE PROTOCOL

Proximity-1 is a bi-directional Space Link Layer protocol for use by space missions. It has been designed to meet the requirements of space missions for efficient transfer of space data over various types and characteristics of Proximity space links. The protocol consists of a Data Link Layer (reference [3]) and a Physical Layer (reference [4]), combined with the Generic Session Establishment Procedure [6]. The Coding and Synchronization (C&S) Sublayer defined in this document is part of the Data Link Layer.

Proximity-1 activities are divided between a send side and a receive side. The send side is concerned with the transmitted physical channel, and also with the acquisition of the received physical channel in order to establish a Proximity-1 link. The receive side is concerned with the reception of data on the received physical channel: the input symbol stream and the protocol data units it contains.

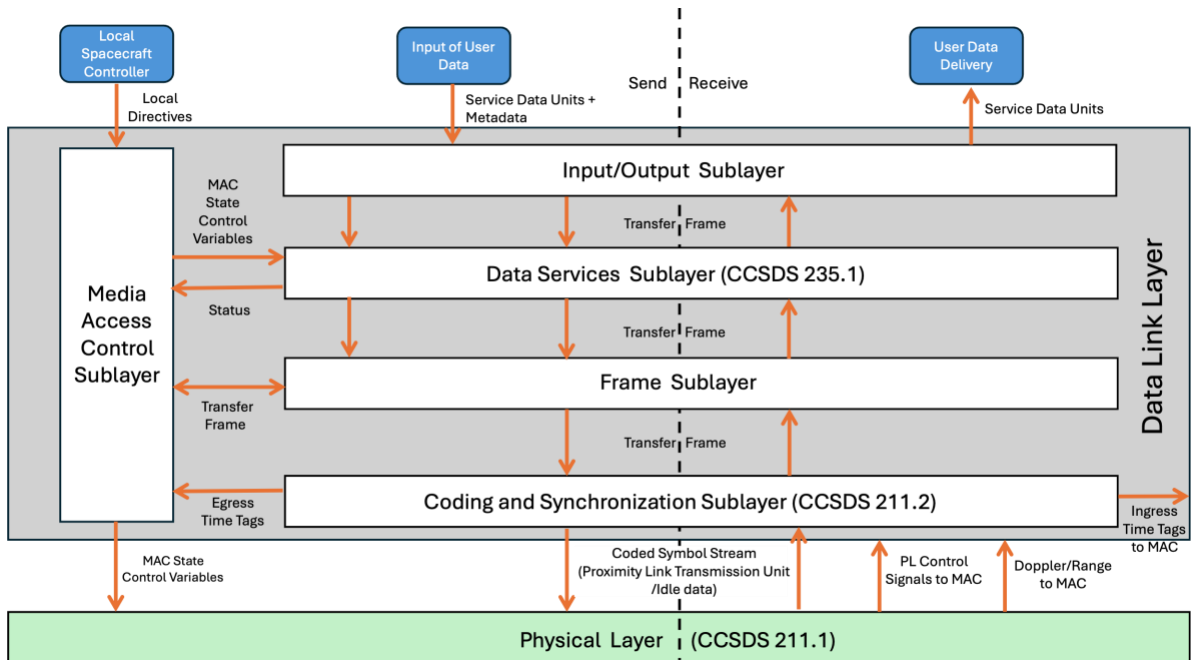

Figure 2-1: Overview of Proximity-1 Layers/Sublayers

### 2.2 PHYSICAL LAYER

On the send side, the Physical Layer

- accepts control variables from the Data Link Layer for control of the transceiver; and
- accepts a stream of Proximity-1 coded symbols from the Data Link Layer for modulation onto the radiated carrier.

On the receive side, the Physical Layer

- provides the serial stream output of Proximity-1 coded symbols from the receiver to the Data Link Layer; and
- provides status signals (CARRIER\_ACQUIRED and SYMBOL\_INLOCK\_STATUS) to the Data Link Layer.

## 2.3 DATA LINK LAYER

This subsection provides a brief overview of the Data Link Layer, with emphasis on the features relevant to the C&S Sublayer. Reference [3] contains a more complete description of the overall Proximity-1 layered protocol, of the Data Link Layer, and of its sublayers.

On the send side, the Data Link Layer is responsible for providing data to be transmitted by the Physical Layer. On the receive side, the Data Link Layer accepts the serial coded symbol stream output from the receiver in the Physical Layer and processes the protocol data units contained in it. The Coding and Synchronization sublayer receives and sends either Proximity-1 or USLP transfer frames.

Within the Data Link Layer, the Medium Access Control (MAC) Sublayer, the Proximity-1 Frame Sublayer, and the USLP Data Link Protocol Sublayer have interfaces to the C&S Sublayer.

The MAC Sublayer controls the operational state of the Data Link and Physical Layers, using control variables. It accepts Proximity-1 directives from both the local vehicle controller and across the Proximity link to control its operations. The MAC Sublayer is also responsible for the storage and distribution of the Management Information Base (MIB) parameters.

Both the Proximity-1 Frame Sublayer and the USLP Data Link Protocol Sublayer include the processing associated with the fields contained in the frame header of the associated Transfer Frame. On the send side, the Proximity-1 Frame Sublayer and the USLP Data Link Protocol Sublayer determine the order of frame transmission and deliver frames to the C&S Sublayer. On the receive side, the Proximity-1 Frame Sublayer and the USLP Data Link Protocol Sublayer receive and validate frames from the C&S Sublayer (reference [6]) and deliver them to the Data Services Sublayer or to the MAC Sublayer, depending on their frame type.

## 2.4 CODING AND SYNCHRONIZATION SUBLAYER

On the send side, the actions of the C&S Sublayer include

- constructing PLTUs, with each PLTU containing a Transfer Frame received from the Proximity-1 Frame Sublayer or the USLP Data Link Protocol Sublayer;
- generation of the bitstream for encoding, inserting Idle data as required;

- channel coding; when the LDPC code is used, the Codeword Sync Marker (CSM) described in 3.4.4 is added for codeword synchronization, as illustrated in figure 3-2; and
- provision of the coded symbols stream at a constant rate ( $R_{cs}$ ) to the Physical Layer for modulation onto the radiated carrier.

On the receive side, the C&S Sublayer actions include

- reception of the coded symbols stream from the receiver in the Physical Layer at a constant rate ( $R_{cs}$ );
- channel decoding; when the LDPC code is used, codeword synchronization using CSM described in 3.4.4 is achieved before channel decoding;
- delimiting of each PLTU, including validation; and
- for each valid PLTU, delivering the delimited Transfer Frame to the Proximity-1 Frame Sublayer or the USLP Data Link Protocol Sublayer.

On both the send and receive sides, the C&S Sublayer supports Proximity-1 timing services defined in reference [3] by capturing the values of the clock, frame sequence number, Quality Of Service (QOS) Indicator, and direction (ingress or egress) associated with each Transfer Frame over the commanded interval.

The (simplified) interaction of the Coding & Synchronization Sublayer with the other (sub) layers at the transmitting (i.e., encoding) side of Proximity-1 is shown in figure 2-2.

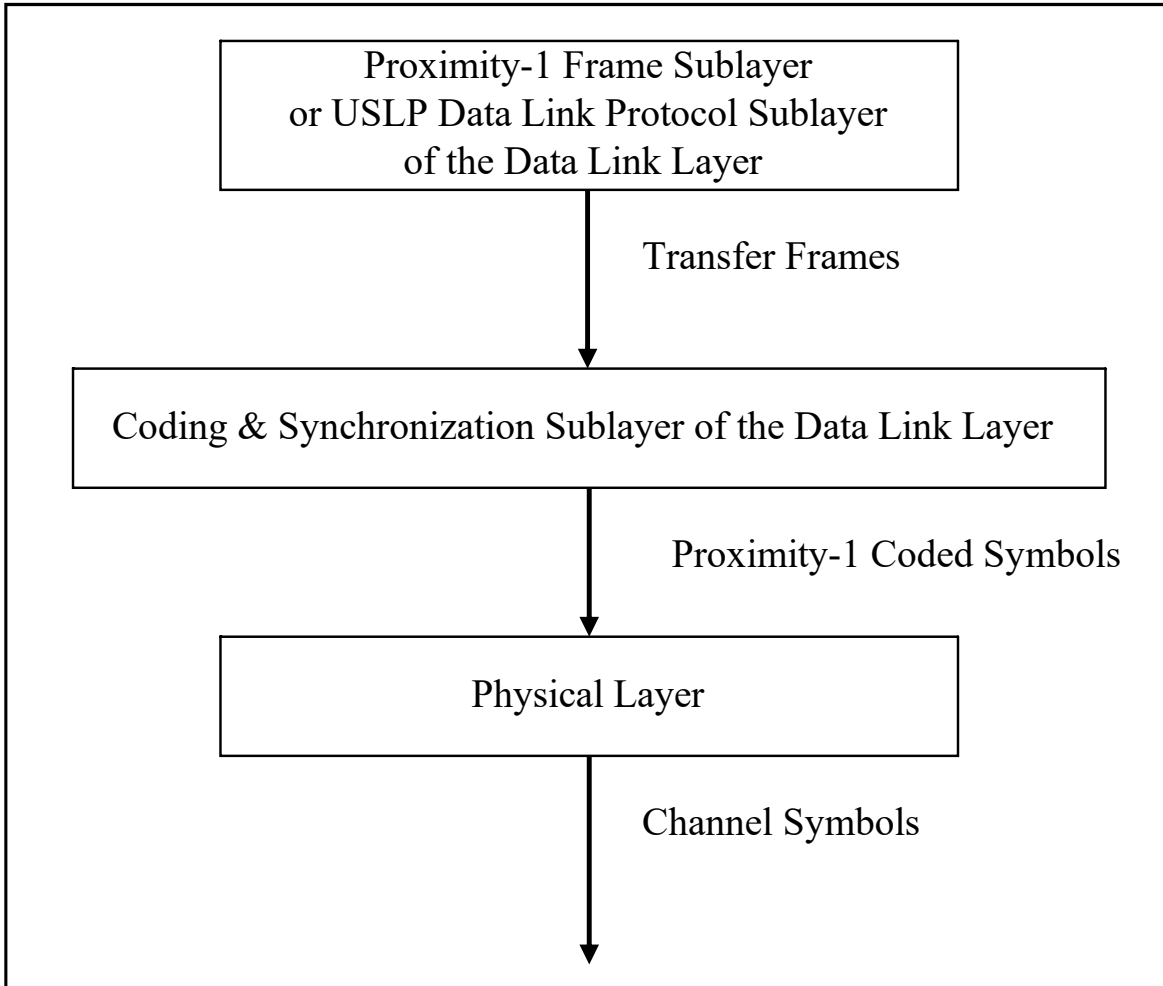

**Figure 2-2: Coding & Synchronization Sublayer Send Side Interactions**

## **3 CODING AND SYNCHRONIZATION SUBLAYER**

### **3.1 OVERVIEW**

On the send side, the C&S Sublayer generates the output coded symbols stream (including PLTUs and Idle data) to be delivered to the Physical Layer for modulation onto the radiated carrier. The PLTU is specified in 3.2. Each PLTU contains a Transfer Frame, specified in either reference [3] or reference [5], that also defines an Output Bitstream FIFO, which holds coded symbol-stream data ready for delivery to the Physical Layer.

The PLTUs form a non-continuous serial stream, consisting of a sequence of variable-length PLTUs, which can have a delay between the end of one PLTU and the start of the next. While establishing a Proximity-1 session for a full- or half-duplex link, synchronization is reacquired for each PLTU, and Idle data is provided for the acquisition process. When no PLTU is available, Idle data is transmitted to maintain synchronization. Idle data is specified in 3.3. The procedures for the session establishment, data services, and session termination phases of a Proximity-1 session are specified in reference [3].

The channel coding options for Proximity-1 are specified in 3.4. The send side and receive side procedures in the C&S Sublayer are specified in 3.5 and 3.6.

### **3.2 PROXIMITY LINK TRANSMISSION UNIT**

#### **3.2.1 PLTU OVERVIEW**

The C&S Sublayer handles the Proximity Link Transmission Unit (PLTU) specified here and the Transfer Frame specified in reference [3] or reference [5]. The PLTU and the Transfer Frame are variable-length data structures.

For the sending end of a link, the C&S Sublayer constructs PLTUs, with each PLTU containing a Transfer Frame. For the receiving end, the C&S Sublayer processes each PLTU and delimits the Transfer Frame.

#### **3.2.2 PLTU STRUCTURE**

A PLTU shall encompass the following three fields, positioned contiguously, in the following sequence:

- a) 24-bit Attached Synchronization Marker (ASM);
- b) Transfer Frame;
- c) 32-bit Cyclic Redundancy Check.

NOTES

- 1 The length of a PLTU depends on the length of the Transfer Frame it contains. The maximum Transfer Frame length for a given mission is established by the MIB parameter `Maximum_Frame_Length` in annex C in reference [3] or in the Managed Parameter Section in reference [5].
- 2 The structural components of the PLTU are shown in figure 3-1.

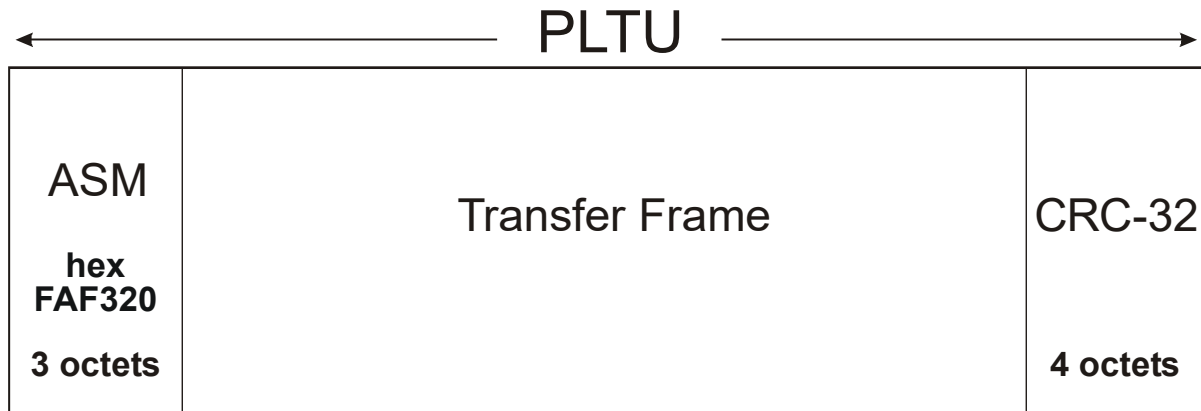

**Figure 3-1: Proximity-1 Link Transmission Unit (PLTU)**

**3.2.3 ATTACHED SYNCHRONIZATION MARKER**

- 3.2.3.1 The ASM shall occupy the first 24 bits of the PLTU.
- 3.2.3.2 The ASM shall consist of the following bit pattern (in hexadecimal): FAF320.

NOTE – At the receiving end, the ASM is used to detect the start of a PLTU.

**3.2.4 TRANSFER FRAME**

- 3.2.4.1 PLTUs shall contain either a Version-3 (Proxymity-1) or a Version-4 (USLP) Transfer Frame.
- 3.2.4.2 The Transfer Frame in a PLTU shall immediately follow the ASM.
- 3.2.4.3 Only transfer frames of the same version number shall be contained in the same PLTU stream.

NOTES

- 1 Transfer Frames with different version numbers in the same PLTU stream are not allowed. This is to avoid the case of mixing variable length with fixed length frames in the same symbol stream.

- 2 The Specification of the Version-3 Transfer Frame is contained in reference [3].
- 3 The Specification of the Version-4 Transfer Frame is contained in reference [5].

### **3.2.5 CYCLIC REDUNDANCY CHECK-32**

**3.2.5.1** The CRC-32 shall occupy the last 32 bits of the PLTU.

**3.2.5.2** The CRC-32 shall immediately follow the Transfer Frame.

**3.2.5.3** The CRC-32 shall be calculated by applying the encoding procedure specified in annex C to the Transfer Frame.

**3.2.5.4** The ASM shall NOT be a part of the encoded data space of the CRC-32.

NOTE – As shown in figure 3-1, the CRC is part of the PLTU, but it is not part of the Transfer Frame. In this respect, Proximity-1 coding differs from other CCSDS space data link protocols.

## **3.3 IDLE DATA**

### **3.3.1 OVERVIEW**

Idle data are included in the bitstream for encoding

- for the purpose of data acquisition (Acquisition sequence);
- when no PLTU is available (Idle sequence); and
- prior to terminating transmission (Tail sequence).

A Pseudo-Noise (PN) sequence defines the bit pattern used for the Idle data in each of these sequences. The PN sequence is cyclic and is repeated as needed.

Reference [3] specifies the uses of the Acquisition sequence, Idle sequence, and Tail sequence in the phases of a Proximity-1 session. It also specifies the MIB parameters *Acquisition\_Idle\_Duration* and *Tail\_Idle\_Duration*, which represent the time that is used to radiate the Acquisition sequence and the Tail sequence.

### **3.3.2 GENERAL**

**3.3.2.1** Idle data shall be included in the bitstream for encoding as follows:

- a) an Acquisition sequence (defined in 3.3.3) shall be inserted when transmission commences;

- b) Idle sequence(s) (defined in 3.3.2 and 3.3.4) shall be inserted when no PLTU is available; and
- c) a Tail sequence (defined in 3.3.5) shall be inserted prior to terminating transmission.

**3.3.2.2** Idle data shall consist of the PN sequence 352EF853 (in hexadecimal), repeated as needed.

**3.3.2.3** When LDPC coding is used, octet synchronization shall be maintained between the PLTUs and LDPC codewords as follows.

- a) The first LDPC message block shall start with the first bit of the Acquisition Sequence, and this shall be the first bit of the PN sequence defined in 3.3.2.2.
- b) The Acquisition Sequence shall be an integer number of octets in lengths.
- c) Idle data inserted between PLTUs shall start with the first bit of the PN sequence defined in 3.3.2.2 and shall be an integer number of octets in length.

NOTE – These synchronization requirements apply only when LDPC coding is used.

**3.3.2.4** Whenever the end of the PN sequence is reached, the sequence shall be repeated starting from the first bit of the PN sequence.

NOTE – An Idle Data Generator can be used to generate Idle data for insertion into the bitstream to be encoded.

### **3.3.3 ACQUISITION SEQUENCE**

#### **3.3.3.1 Overview**

The Physical Layer provides the modulation necessary for the partners in a session to acquire and process each other's transmission. When transmission commences, the transmitter's modulation is sequenced (first carrier only followed by an Acquisition Sequence) such that the receiving unit can acquire the signal and achieve a reliable channel symbol stream in preparation for acceptance of the transmitted data units. If convolutional code is applied (see 3.4), the Acquisition Sequence is also used to achieve node synchronization in the decoder (reference [E1]). If LDPC code is used, the acquisition sequence duration is set long enough for a valid CSM to be detected after symbol synchronization is established and before the first PLTU begins.

#### **3.3.3.2 Requirements**

**3.3.3.2.1** The Acquisition sequence shall consist of data as specified by the requirements in 3.3.3.2 above.

**3.3.3.2.2** The Acquisition sequence shall be transmitted for the duration specified by the MIB parameter `Acquisition_Idle_Duration` specified in reference [3].

NOTE – In case of LDPC, the acquisition sequence must be composed of an integer number of octets, as specified in section 3.3.2.3b.

### **3.3.4 IDLE SEQUENCE**

#### **3.3.4.1 Overview**

While in the data transfer phase of a Proximity-1 session, (encoded) PLTUs are transmitted within a continuous stream of channel symbols from the transmitter to the receiver. When no PLTU is available, the Idle sequence is injected into the bit stream to be encoded in order to keep the channel symbols stream flowing and to enable the receiver to maintain synchronization.

#### **3.3.4.2 Requirements**

**3.3.4.2.1** The Idle sequence shall consist of data as specified by the requirements in 3.3.3.2 above.

**3.3.4.2.2** During the data services phase, if no PLTU is ready for transfer, then the Idle sequence shall be transmitted.

### **3.3.5 TAIL SEQUENCE**

#### **3.3.5.1 Overview**

Prior to terminating transmission (removing modulation), the transmitter transmits a series of idle bits (Tail sequence) for a fixed period. This can help the receiving unit to maintain bit lock and convolutional decoding while it completes the processing of the final received data unit.

#### **3.3.5.2 Requirements**

**3.3.5.2.1** The Tail sequence shall consist of data as specified by the requirements in 3.3.3.2, above.

**3.3.5.2.2** The Tail sequence shall be transmitted for the duration specified by the MIB parameter `Tail_Idle_Duration`, specified in reference [3].

## 3.4 CHANNEL CODING

### 3.4.1 OVERVIEW OF PROXIMITY-1 CHANNEL CODING

This document defines four channel codes for use on Proximity-1 links: an optional convolutional code and three optional LDPC code.

NOTE – Some transceivers implement additional channel codes to those defined in the Proximity-1 recommended standards. The additions include a pair of Reed-Solomon codes, which can be enabled or disabled by the SET PL EXTENSIONS Type 1 directive defined in annex B1 of reference [3]. The Reed-Solomon codes are not specified in the CCSDS Proximity-1 space link Recommended Standards, and their use is not intended for cross-support applications.

### 3.4.2 CODING OPTIONS

**3.4.2.1** The C&S Sublayer shall process the incoming Transfer Frames and produce a bitstream for encoding (including PLTUs and Idle Data) at data rate  $R_d$ .

#### NOTES

- 1 The configuration  $R_d$  of the current data rate varies depending on whether the Data Link Layer protocol adheres to Type 1 or Type 5 of the referenced document [3].
- 2 The current data rate is configured using the SET TRANSMITTER PARAMETERS and SET PL EXTENSIONS directives defined as part of the Type 1 directives of reference [3], and it is selected among the following discrete data rates, shown in bits per second: 1000, 2000, 4000, 8000, 16000, 32000, 64000, 128000, 256000, 512000, 1024000, 2048000. When LDPC codes are used, these  $R_d$  values are approximated, and the true values can be found in annex A of reference [3].
- 3 The current data rate is configured using the Link Establishment & Control directive defined as part of the Type 5 directives of reference [3], and it is selected in such a way that the corresponding  $R_{cs}$  value falls in the interval 1000 sps – 4096000 sps.

**3.4.2.2** The C&S Sublayer shall generate the output stream of Proximity-1 coded symbols applying only one of the following coding options:

- a) no coding;
- b) convolutional code (see 3.4.3);
- c) LDPC code (see 3.4.4)  $k=1024$  and  $R=1/2$ ;
- d) LDPC code (see 3.4.5)  $k=4096$  and  $R=2/3$ .
- e) LDPC code (see 3.4.6)  $k=7136$  and  $R=7/8$ .

NOTES

- 1 Depending on the selected Data Link Layer specific protocol, Type 1 or Type 5 of reference [3], some of the coding option listed above may be not available. In particular:
  - Coding option a) is only possible with Bi-Phase-L Modulation both for Type 1 and Type 5 directives.
  - Coding option b) is only possible for Type 1 directives.
  - Coding option c) is possible with both Type 1 and Type 5 directives.
  - Coding options d) and e) are only Type 5 directives.
  
- 2 The directives SET TRANSMITTER PARAMETERS and SET RECEIVER PARAMETERS defined in Type 1 directives of reference [3] include an option to concatenate the convolutional code with one of the Reed-Solomon codes. Neither the Reed-Solomon code nor the concatenation with the convolutional code is specified here.

Figure 3-2 below shows the principal behavior of the C&S Sublayer.

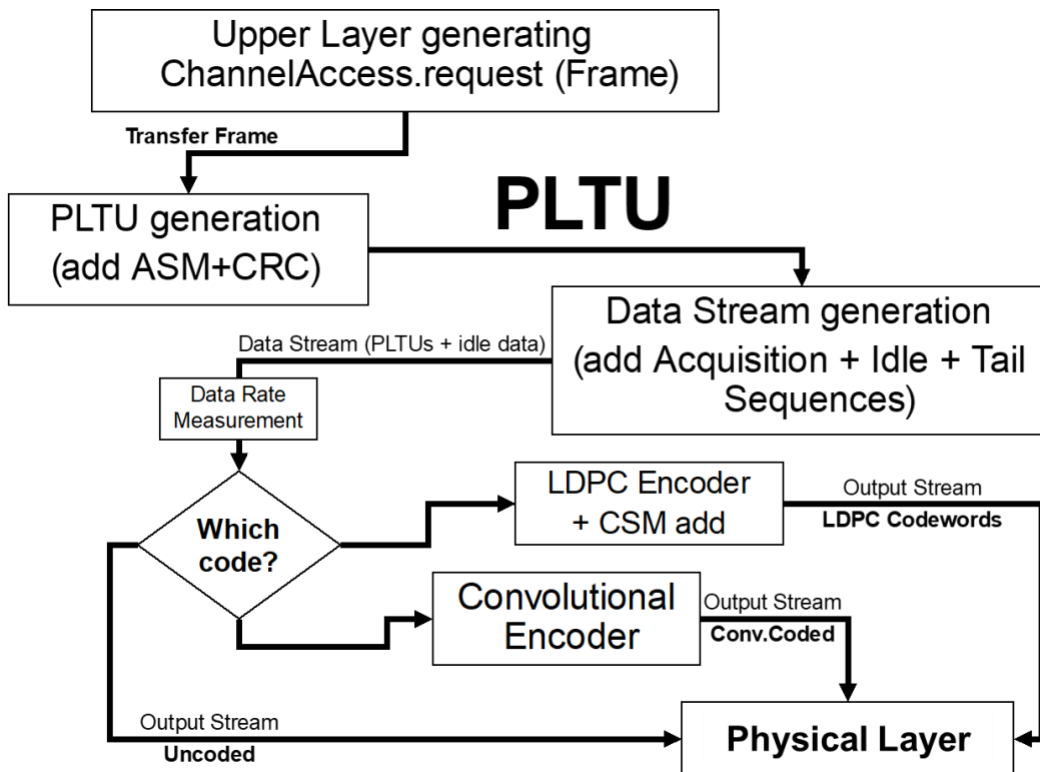

Figure 3-2: Behavior of the C&S Sublayer

### 3.4.3 CONVOLUTIONAL CODE

**3.4.3.1** The convolutional code shall be the rate  $1/2$ , constraint-length 7 convolutional code defined in reference [2].

#### NOTES

- 1 The convolutional encoding process does contain symbol inversion on the output path of connection vector  $G_2$ .
- 2 Only the non-punctured convolutional code from reference [2] is specified for use on Proximity-1 links.

**3.4.3.2** When the convolutional code is applied, all data to be transmitted, that is, PLTUs and Idle data, shall be convolutionally encoded.

#### NOTES

- 1 The format of Idle data is specified in 3.3.
- 2 All transmitted bits are convolutionally encoded; therefore the ASM and CRC in the PLTU are also encoded.

**3.4.3.3** Soft bit decisions with at least three bits quantization are recommended whenever constraints (such as complexity of decoder) permit.

### 3.4.4 LDPC CODE $k=1024$ AND $r=1/2$

**3.4.4.1** When the LDPC  $k=1024$  and  $R=1/2$  code is used, fixed-length LDPC message blocks of length  $k=1024$  bits shall be constructed as follows.

- a) PLTUs shall be generated as described in 3.2.
- b) Idle data shall then be inserted between PLTUs as necessary (i.e., before the first PLTU, between PLTUs, and after the last PLTU), according to 3.3.
- c) The resulting bitstream shall then be partitioned into LDPC message blocks 1024 bits in length.

NOTE – Idle Data include Acquisition, Idle, and Tail Sequences.

**3.4.4.2** The first LDPC message block shall start with the first bit of the Acquisition sequence, and this shall be the first bit of the PN sequence defined in 3.3.2.2.

**3.4.4.3** Each LDPC message block shall be encoded using the LDPC code ( $n=2048$ ,  $k=1024$ ) rate  $1/2$  code defined in reference [2].

**3.4.4.4** The LDPC Codewords shall be randomized according to 3.4.7.

**3.4.4.5** LDPC Codewords shall be synchronized by using a stream of fixed-length LDPC Codewords with a CSM between them.

NOTE – Synchronization is acquired on the receiving end by recognizing the specific pattern of the CSM in the physical channel data stream; synchronization shall then customarily be verified by making further checks.

**3.4.4.6** The CSM shall consist of a 64-bit (8-octet) marker with the following bit pattern (in hexadecimal): 0347 76C7 2728 95B0.

**3.4.4.7** The CSM shall immediately precede the LDPC codeword.

**3.4.4.8** The CSM shall immediately follow the end of the preceding LDPC codeword; that is, there shall be no intervening bits (data or fill) preceding the CSM.

NOTE – The LDPC coding procedure is shown in figure 3-3.

### **3.4.5 LDPC CODE $k=4096$ AND $r=2/3$**

**3.4.5.1** When the LDPC  $k=4096$  and  $R=2/3$  code is used, fixed length LDPC message blocks of length  $k=4096$  bits shall be constructed as follows.

- a) PLTUs shall be generated as described in 3.2.
- b) Idle data shall then be inserted between PLTUs as necessary (i.e., before the first PLTU, between PLTUs, and after the last PLTU), according to 3.3.
- c) The resulting bitstream shall then be partitioned into LDPC message blocks 4096 bits in length.

NOTE – Idle Data include Acquisition, Idle, and Tail Sequences.

**3.4.5.2** The first LDPC message block shall start with the first bit of the Acquisition sequence, and this shall be the first bit of the PN sequence defined in 3.3.2.2.

**3.4.5.3** Each LDPC message block shall be encoded using the LDPC code ( $n=6144$ ,  $k=4096$ ) rate  $2/3$  code defined in reference [2].

**3.4.5.4** The LDPC Codewords shall be randomized according to 3.4.7.

**3.4.5.5** LDPC Codewords shall be synchronized by using a stream of fixed-length LDPC Codewords with a CSM between them.

NOTE – Synchronization is acquired on the receiving end by recognizing the specific pattern of the CSM in the physical channel data stream; synchronization shall then customarily be verified by making further checks.

**3.4.5.6** The CSM shall consist of a 64-bit (8-octet) marker with the following bit pattern (in hexadecimal): 0347 76C7 2728 95B0.

**3.4.5.7** The CSM shall immediately precede the LDPC codeword.

**3.4.5.8** The CSM shall immediately follow the end of the preceding LDPC codeword; that is, there shall be no intervening bits (data or fill) preceding the CSM.

NOTE – The LDPC coding procedure is shown in figure 3-3.

### **3.4.6 LDPC CODE $k=7136$ AND $r=7/8$**

**3.4.6.1** When the LDPC  $k=7136$  and  $R=7/8$  code is used, fixed length LDPC message blocks of length  $k=7136$  bits shall be constructed as follows.

- a) PLTUs shall be generated as described in 3.2.
- b) Idle data shall then be inserted between PLTUs as necessary (i.e., before the first PLTU, between PLTUs, and after the last PLTU), according to 3.3.
- c) The resulting bitstream shall then be partitioned into LDPC message blocks 4096 bits in length.

NOTE – Idle Data include Acquisition, Idle, and Tail Sequences.

**3.4.6.2** The first LDPC message block shall start with the first bit of the Acquisition sequence, and this shall be the first bit of the PN sequence defined in 3.3.2.2.

**3.4.6.3** Each LDPC message block shall be encoded using the LDPC code ( $n=8160$ ,  $k=7136$ ) rate  $7/8$  code defined in reference [2].

**3.4.6.4** The LDPC Codewords shall be randomized according to 3.4.7.

**3.4.6.5** LDPC Codewords shall be synchronized by using a stream of fixed-length LDPC Codewords with a CSM between them.

NOTE – Synchronization is acquired on the receiving end by recognizing the specific pattern of the CSM in the physical channel data stream; synchronization shall then customarily be verified by making further checks.

**3.4.6.6** The CSM shall consist of a 32-bit (4-octet) marker with the following bit pattern (in hexadecimal): 1ACFFC1D.

**3.4.6.7** The CSM shall immediately precede the LDPC codeword.

**3.4.6.8** The CSM shall immediately follow the end of the preceding LDPC codeword; that is, there shall be no intervening bits (data or fill) preceding the CSM.

NOTE – The LDPC coding procedure is shown in figure 3-3.

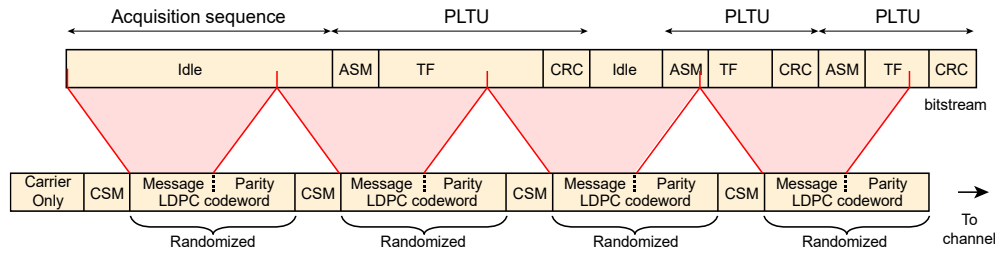

**Figure 3-3: LDPC Coding Procedure**

### 3.4.7 RANDOMIZATION OF LDPC CODEWORDS

#### 3.4.7.1 Discussion

Since the LDPC code is quasi-cyclic, the LDPC codewords require randomization in order to minimize the probability of false synchronization due to potential symbol slips. When LDPC coding is used, this is achieved using the pseudo-randomizer defined in this section. When LDPC coding is used, a random sequence is exclusively ORed with the LDPC codewords to increase the frequency of bit transitions. On the receiving end, the same random sequence is exclusively ORed with the decoded LDPC codewords, restoring the original data form. The random sequence is generated by the pseudo-randomizer defined in this section.

#### 3.4.7.2 Requirements

**3.4.7.2.1** On the sending end, the pseudo-randomizer shall be applied to the LDPC Codeword.

**3.4.7.2.2** On the receiving end, the pseudo-randomizer shall be applied to de-randomize the randomized LDPC Codewords before decoding.

**3.4.7.2.3** The CSM shall be used for synchronizing the pseudo-randomizer.

**3.4.7.2.4** The pseudo-random sequence shall be applied starting with the first bit of the LDPC Codeword.

**3.4.7.2.5** On the sending end, the LDPC Codeword shall be randomized by exclusive-ORing the first bit of the Codeword with the first bit of the pseudo-random sequence, followed by the second bit of the Codeword with the second bit of the pseudo-random sequence, and so on.

**3.4.7.2.6** On the receiving end, the original Codeword shall be reconstructed (i.e., de-randomized) using the same pseudo-random sequence.

**3.4.7.2.7** After locating the CSM in the received data stream, the data immediately following the CSM shall be de-randomized.

NOTES

- 1 The CSM was not randomized and is not de-randomized.
- 2 De-randomization can be accomplished by performing exclusive-OR with hard bits or inversion with soft bits.

**3.4.7.2.8** The random sequence shall be generated using the following polynomial:

$$h(x) = x^8 + x^6 + x^4 + x^3 + x^2 + x + 1$$

NOTE – This is the same polynomial used in reference [E3]. Designers should note that this length-255-bit pseudo-randomizer may introduce spectral lines at 1/255 of the symbol rate, and these may be significant in some systems.

**3.4.7.2.9** The random sequence shall begin at the first bit of the LDPC Codeword and shall repeat after 255 bits, continuing repeatedly until the end of the Codeword.

**3.4.7.2.10** The sequence generator shall be initialized with the all-ones state at the start of each Codeword.

NOTES

- 1 The first 40 bits of the pseudo-random sequence from the generator are shown below. The leftmost bit is the first bit of the sequence to be exclusive-ORed with the first bit of the Codeword; the second bit of the sequence is exclusive-ORed with the second bit of the Codeword; and so on.

1111 1111 0011 1001 1001 1110 0101 1010 0110 1000

- 2 Figure 3-4 represents a possible generator for the specified sequence.

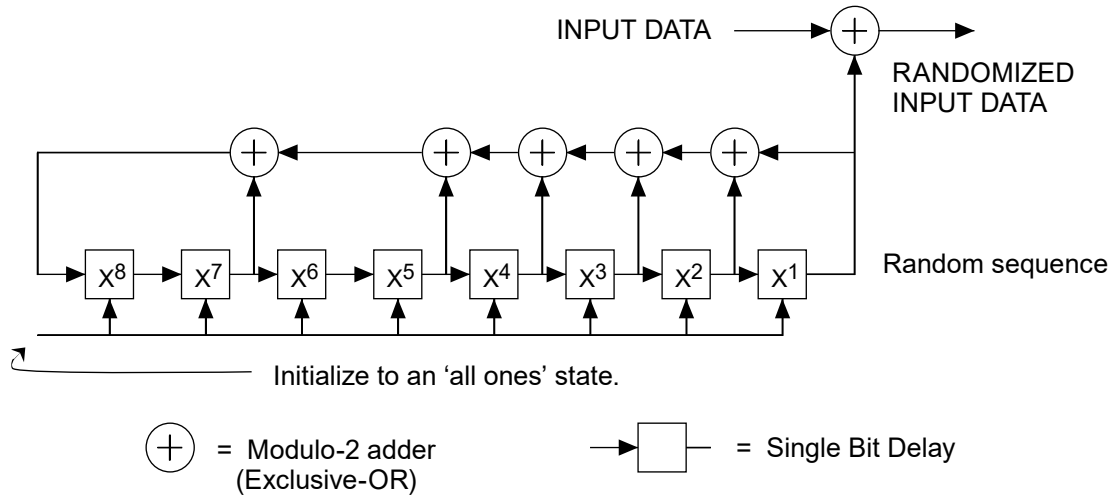

**Figure 3-4: Pseudo-Randomizer Logic Diagram**

### 3.5 SEND SIDE PROCEDURES IN THE C&S SUBLAYER

**3.5.1** The C&S Sublayer shall accept Transfer Frames from the Proximity-1 Frame Sublayer or the USLP Data Link Protocol Sublayer.

**3.5.2** For each frame, the C&S Sublayer shall construct a PLTU containing the frame.

**3.5.3** The C&S Sublayer shall generate the bitstream for encoding by inserting Idle data as required.

**3.5.4** The C&S Sublayer shall apply the selected encoding (see 3.4.2.2) and generate the output coded symbol stream. When the LDPC code is used, the CSM shall be added as described in 3.4.4.

**3.5.5** The C&S Sublayer shall deliver the generated output coded symbol stream to the Physical Layer at a constant rate ( $R_{cs}$ ).

**3.5.6** When time tag collection is active,

- a) before computing CRC, the C&S Sublayer shall store the values of the clock, frame sequence number, QOS Indicator, and direction (egress) of each outgoing Transfer Frame; and
- b) the captured clock value shall correspond to when the trailing edge of the last bit of the ASM of the outgoing PLTU crosses the clock capture point (defined by the implementation) within the transceiver.

NOTE – The captured clock value is eventually processed to provide a value corresponding to a common reference point as described in reference [3] section 5, Proximity-1 Timing Services.

### 3.6 RECEIVE SIDE PROCEDURES IN THE C&S SUBLAYER

**3.6.1** The C&S Sublayer shall accept the received coded symbols stream from the Physical Layer.

NOTE – The Physical Layer delivers the coded symbols stream at a given rate. Such a rate is configured using either Type 1 or Type 5 directives defined in Annex B of reference [3].

**3.6.2** The C&S Sublayer shall apply the decoding of the selected channel coding option defined in 3.4.2.2. When the LDPC codes are used, codeword synchronization shall be achieved using CSM as described in 3.4.4 and 3.4.5.

**3.6.3** The C&S Sublayer shall use the ASM to locate the beginning of a PLTU for frame synchronization with the Transfer Frame it contains.

NOTE – For the purpose of frame synchronization, an implementation can choose to recognize an ASM with bit errors.

**3.6.4** For each frame, the C&S Sublayer shall test for the value of the Transfer Frame Version Number (TFVN) to aid in locating the position of the CRC-32 field of the PLTU as follows:

- a) If the first two bits of the Transfer Frame header are ‘10’, indicating a 2-bit TFVN field and a Transfer Frame version of 10 binary (i.e., Version-3 Proximity-1 frame), then the C&S Sublayer shall use the Proximity-1 Frame Length Field of the Transfer Frame to locate the position of the CRC-32 field in the PLTU.
- b) If the first two bits of the Transfer Frame header are ‘11’, indicating a 4-bit TFVN field, and the version of the Transfer Frame is 1100 binary (i.e., Version-4 USLP frame),
  - 1) if the USLP End of Frame Primary Header Flag is ‘0’ (i.e., USLP *non-truncated* Transfer Frame is present), then the C&S Sublayer shall use the USLP Frame Length Field of the Transfer Frame to locate the position of the CRC-32 field in the PLTU;
  - 2) if the USLP End of Frame Primary Header Flag is ‘1’ (i.e., USLP *truncated* Transfer Frame present), then the C&S Sublayer shall use the USLP Truncated Transfer Frame Length Managed Parameter to locate the position of the CRC-32 field in the PLTU.
- c) If the version number of the Transfer Frame is not recognized, the C&S Sublayer shall continue searching the received coded symbol stream for the ASM of the next PLTU.

#### NOTES

- 1 The CRC-32 marks the end of the PLTU, which can be followed by Idle data. The C&S Sublayer searches the received coded symbol stream following the end of the PLTU, looking for the ASM of the next PLTU, so any intervening idle bits are discarded.

- 2 The location and the size of the Frame Length field are protocol dependent. Version-3 Transfer Frames use a 2-bit TFVN. Version 4 Transfer Frames use a 4-bit TFVN. (See references [3] or [5] for specific details.)
- 3 Version 4 USLP frames that contain a Truncated Transfer Frame Primary Header do not contain a Length Field and are always of fixed size.

**3.6.5** The C&S Sublayer shall apply the CRC-32 decoding procedure to the received CRC-32 codeword in a PLTU, to check for errors in the received frame.

**3.6.6** If the CRC-32 decoding detects any error in the CRC-32 codeword, the C&S Sublayer shall mark the received frame as invalid.

NOTE – As defined in annex B, which provides service definition in the form of primitives, the received frame indication is passed from the service provider to the service user at the receiving end, and frame handling depends on the specific implementation approaches (e.g., the invalid frames may be discarded or not).

**3.6.7** The C&S Sublayer shall deliver the received frames to the Proximity-1 Frame Sublayer or the USLP Data Link Protocol Sublayer.

**3.6.8** When time tag collection is active,

- a) after decoding, the C&S Sublayer shall store the values of the clock, frame sequence number, QOS Indicator, and direction (ingress) of each received Transfer Frame; and
- b) the captured clock value shall correspond to when the trailing edge of the last bit of the ASM of the received PLTU crosses the clock capture point (defined by the implementation) within the transceiver.

NOTE – The captured clock value is eventually processed to provide a value corresponding to a common reference point as described in reference [3] section 5, Proximity-1 Timing Services.

## ANNEX A

### PROTOCOL IMPLEMENTATION CONFORMANCE STATEMENT PROFORMA

#### (NORMATIVE)

#### A1 INTRODUCTION

##### A1.1 OVERVIEW

This annex provides the Protocol Implementation Conformance Statement (PICS) Requirements List (RL) for an implementation of *Proximity-1 Space Link Protocol—Coding and Synchronization Sublayer* (CCSDS 211.2-B-4). The PICS for an implementation is generated by completing the RL in accordance with the instructions below. An implementation claiming conformance must satisfy the mandatory requirements referenced in the RL.

The RL support column in this annex is blank. An implementation's completed RL is called the PICS. The PICS states which capabilities and options have been implemented. The following can use the PICS:

- the implementer, as a checklist to reduce the risk of failure to conform to the standard through oversight;
- a supplier or potential acquirer of the implementation, as a detailed indication of the capabilities of the implementation, stated relative to the common basis for understanding provided by the standard PICS proforma;
- a user or potential user of the implementation, as a basis for initially checking the possibility of interworking with another implementation (it should be noted that, while interworking can never be guaranteed, failure to interwork can often be predicted from incompatible PICSes);
- a tester, as the basis for selecting appropriate tests against which to assess the claim for conformance of the implementation.

##### A1.2 ABBREVIATIONS AND CONVENTIONS

The RL consists of information in tabular form. The status of features is indicated using the abbreviations and conventions described below.

##### Item Column

The item column contains sequential numbers for items in the table

### Feature Column

The feature column contains a brief descriptive name for a feature. It implicitly means: ‘is this feature supported by the implementation?’

### Status Column

The status column uses the following notations:

- M            mandatory.
- O            optional.
- O.<n>        optional, but support of at least one of the group of options labeled by the same numeral <n> is required.
- N/A        Not applicable.

### Support Column Symbols

The support column is to be used by the implementer to state whether a feature is supported by entering Y, N, or N/A, indicating:

- Y        Yes, supported by the implementation.
- N        No, not supported by the implementation.
- N/A     Not applicable.

The support column should also be used, when appropriate, to enter values supported for a given capability.

## **A1.3 INSTRUCTIONS FOR COMPLETING THE RL**

An implementer shows the extent of compliance to the Recommended Standard by completing the RL; that is, the state of compliance with all mandatory requirements and the options supported are shown. The resulting completed RL is called a PICS. The implementer shall complete the RL by entering appropriate responses in the support or values supported column, using the notation described in A1.2. If a conditional requirement is inapplicable, N/A should be used. If a mandatory requirement is not satisfied, exception information must be supplied by entering a reference  $X_i$ , where  $i$  is a unique identifier, to an accompanying rationale for the noncompliance.

**A2 PICS PROFORMA FOR PROXIMITY-1 SPACE LINK PROTOCOL—CODING AND SYNCHRONIZATION SUBLAYER (CCSDS 211.2-B-3)**

**A2.1 GENERAL INFORMATION**

**A2.1.1 Identification of PICS**

Date of Statement (DD/MM/YYYY)	
PICS serial number	
System Conformance statement cross-reference	

**A2.1.2 Identification of Implementation Under Test (IUT)**

Implementation name	
Implementation version	
Special Configuration	
Other Information	

**A2.1.3 Identification of Supplier**

Supplier	
Contact Point for Queries	
Implementation Name(s) and Versions	
Other information necessary for full identification, e.g., name(s) and version(s) for machines and/or operating systems;	
System Name(s)	

**A2.1.4 Identification of Specification**

CCSDS 211.2-B-3	
Have any exceptions been required?	Yes [ ] No [ ]
<p>NOTE – A YES answer means that the implementation does not conform to the Recommended Standard. Non-supported mandatory capabilities are to be identified in the PICS, with an explanation of why the implementation is non-conforming.</p>	

## A2.2 REQUIREMENTS LIST

Item	Description	Reference	Status	Support
1	PLTU structure: ASM, Transfer Frame, CRC	3.2	M	
2	Idle data	3.3	M	
3	Coding option: uncoded data	3.4	O.1	
4	Coding option: convolutional	3.4.3	O.1	
5	Coding option: LDPC	3.4.4, 3.4.5, 3.4.6	O.1	
6	Randomizer	3.4.7	O.1	
7	Time tag support	3.5.6, 3.6.8	O	
8	Transfer Frame Version Number	3.6.4	M	
8.1	Proximity-1 Frame Length Field	Reference [3], subsection 3.2.2.10	M	
8.2	USLP Frame Length Field	Reference [5], subsection 4.1.2.7	M	
8.3	USLP Truncated Transfer Frame Length	Reference [5], table 5-3	M	
9	Handling of invalid received frames	3.6.6	M	

O.1 It is mandatory to support at least one of these items.

## **ANNEX B**

### **SERVICE**

#### **(NORMATIVE)**

#### **B1 BACKGROUND**

This annex provides service definitions in the form of primitives, which present an abstract model of the logical exchange of data and control information between the service provider and the service user. The definitions of primitives are independent of specific implementation approaches.

The parameters of the primitives are specified in an abstract sense and specify the information to be made available to the user of the primitives. The way in which a specific implementation makes this information available is not constrained by this specification. In addition to the parameters specified in this annex, an implementation can provide other parameters to the service user (e.g., parameters for controlling the service, monitoring performance, facilitating diagnosis, and so on).

#### **B2 OVERVIEW OF THE SERVICE**

**B2.1** The Proximity-1 Synchronization and Channel Coding provides unidirectional (one-way) transfer of a sequence of variable-length Transfer Frames at a variable frame rate over a physical channel across a space link, with optional error detection/correction.

**B2.2** Only one user can use this service on a physical channel, and Transfer Frames from different users are not multiplexed together within one physical channel.

#### **B3 SERVICE PARAMETERS**

##### **B3.1 FRAME**

The Frame parameter is the service data unit of this service and shall be a Transfer Frame defined in reference [3] or in reference [5].

##### **B3.2 QUALITY INDICATOR**

The Quality Indicator parameter shall be used to notify the user at the receiving end of the service that there is an uncorrectable error in the received Transfer Frame.

## **B4 SERVICE PRIMITIVES**

### **B4.1 GENERAL**

**B4.1.1** The service primitives associated with this service are

- a) ChannelAccess.request; and
- b) ChannelAccess.indication.

**B4.1.2** The ChannelAccess.request primitive shall be passed from the service user at the sending end to the service provider to request that a Frame be transferred through the physical channel to the user at the receiving end.

**B4.1.3** The ChannelAccess.indication shall be passed from the service provider to the service user at the receiving end to deliver a Frame.

### **B4.2 CHANNELACCESS.REQUEST**

#### **B4.2.1 Function**

The ChannelAccess.request primitive is the service request primitive for this service.

#### **B4.2.2 Semantics**

The ChannelAccess.request primitive shall provide a parameter as follows:

ChannelAccess.request      (Frame)

#### **B4.2.3 When Generated**

The ChannelAccess.request primitive shall be passed to the service provider to request it to process and send the Frame.

#### **B4.2.4 Effect on Receipt**

Receipt of the ChannelAccess.request primitive shall cause the service provider to transfer the Frame through the physical channel to the user at the receiving end.

#### **B4.2.5 Additional Comments**

None.

### **B4.3 CHANNELACCESS.INDICATION**

#### **B4.3.1 Function**

The ChannelAccess.indication primitive is the service indication primitive for this service.

#### **B4.3.2 Semantics**

The ChannelAccess.indication primitive shall provide parameters as follows:

ChannelAccess.indication (Frame,  
Quality Indicator)

#### **B4.3.3 When Generated**

The ChannelAccess.indication primitive shall be passed from the service provider to the service user at the receiving end to deliver a Frame.

#### **B4.3.4 Effect on Receipt**

The effect on receipt of the ChannelAccess.indication primitive by the service user is undefined.

#### **B4.3.5 Additional Comments**

None.

## ANNEX C

### CRC-32 CODING PROCEDURES

#### (NORMATIVE)

#### C1 CRC-32 ENCODING PROCEDURE

**C1.1** For the encoding procedure, the  $(n-32)$ -bit Transfer Frame shall be the information message.

**C1.2** The encoding procedure shall accept an  $(n-32)$ -bit Transfer Frame and generate a systematic binary  $(n, n-32)$  block code by appending a CRC-32 as the final 32 bits of the PLTU, as shown in figure 3-1.

#### NOTES

- 1 The Bit Numbering Convention as specified in 1.6.2 is applicable below.
- 2 The ASM is NOT used for computing the CRC-32.

**C1.3** If  $M(X)$  is the  $(n-32)$ -bit information message to be encoded expressed as a polynomial with binary coefficients, with the first bit transferred being the most significant bit  $M_0$  taken as the coefficient of the highest power of  $X$ , then the equation for the 32-bit Cyclic Redundancy Check, expressed as a polynomial  $R(X)$  with binary coefficients, shall be

$$R(X) = [X^{32} \cdot M(X)] \text{ modulo } G(X),$$

where  $G(X)$  is the generating polynomial given by

$$G(X) = X^{32} + X^{23} + X^{21} + X^{11} + X^2 + 1,$$

and where the first transferred bit of the Cyclic Redundancy Check is the most significant bit  $R_0$  taken as the coefficient of the highest power of  $X$ .

**C1.4** The  $n$ -bit CRC-32–encoded block, expressed as a polynomial  $C(X)$  with binary coefficients, shall be

$$C(X) = X^{32} \cdot M(X) + R(X).$$

The  $(n-32)$  bits of the message are input in the order  $M_0, \dots, M_{n-33}$ , and the  $n$  bits of the codeword are output in the order  $C_0, \dots, C_{n-1} = M_0, \dots, M_{n-33}, R_0, \dots, R_{31}$ .

NOTE – A possible implementation of an encoder is described in Figure C-1. For each frame, the shift register is preset to the ‘all zero’ state prior to encoding. This initialization differs from that performed for the 16-bit CRC described in other CCSDS books, for which the cells are initialized to all ‘ones’. The ganged switch is in position 1 while the information bits are being transferred and in position 2 for the 32 Cyclic Redundancy Check bits.

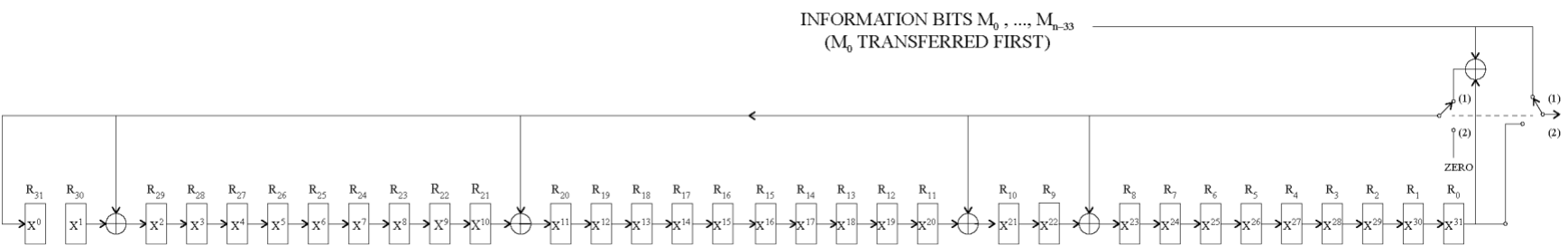

**Figure C-1: A Possible Implementation of Encoder**

## C2 CRC-32 DECODING PROCEDURE

**C2.1** The decoding procedure shall accept an  $n$ -bit received codeword, including the 32-bit Cyclic Redundancy Check, and generates a 32-bit syndrome. An error is detected if and only if at least one of the syndrome bits is non-‘zero’.

**C2.2** The received block  $C^*(X)$  shall equal the transmitted codeword  $C(X)$  plus (modulo two) the  $n$ -bit error block  $E(X)$ ,  $C^*(X) = C(X) + E(X)$ , where both are expressed as polynomials of the same form, that is, with the most significant bit  $C_0$  or  $E_0$  taken as the binary coefficient of the highest power of  $X$ .

**C2.3** With  $C^*(X)$  being the  $n$ -bit received codeword with the first transferred bit being the most significant bit  $C_0^*$  taken as the coefficient of the highest power of  $X$ , then the equation for the 32-bit syndrome, expressed as a polynomial  $S(X)$  with binary coefficients, shall be

$$S(X) = [X^{32} \cdot C^*(X)] \text{ modulo } G(X).$$

The syndrome polynomial will be ‘zero’ if no error is detected and non-‘zero’ if an error is detected, with the most significant bit  $S_0$  taken as the coefficient of the highest power of  $X$ .

NOTE – A possible implementation of the syndrome polynomial generator is described in figure C-2. For each frame, the shift register cells are initialized to ‘zero’. This initialization differs from that performed for the 16-bit CRC described in other CCSDS books, for which the cells are initialized to all ‘ones’. The codeword includes  $n$  bits, that is,  $(n-32)$  information message bits plus the 32 bits of the Cyclic Redundancy Check. All the  $n$  bits of the codeword are clocked into the input, and then the storage stages are examined. For an error-free block, the contents of the shift register cells will be zero. A non-zero content indicates an erroneous block.

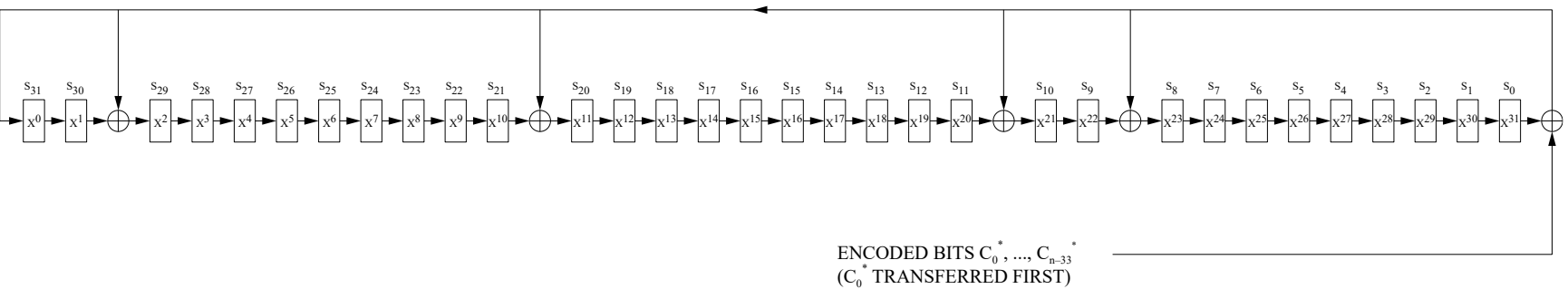

**Figure C-2: A Possible Implementation of the Decoder**

## **ANNEX D**

### **SECURITY, SANA, AND PATENT CONSIDERATIONS**

#### **(INFORMATIVE)**

#### **D1 SECURITY CONSIDERATIONS**

##### **D1.1 BACKGROUND**

It is assumed that security is provided by encryption, authentication methods, and access control to be performed at higher layers (Application and/or Transport Layers). Mission and service providers are expected to select from recommended security methods, suitable to the specific application profile. Specification of these security methods and other security provisions is outside the scope of this Recommended Standard. The C&S Sublayer has the objective of delivering data with the minimum possible amount of residual errors. The Proximity-1 codes ensure a very low error probability, and the Frame Error Control Field is used to ensure that residual errors are detected and the frame flagged. There is an extremely low probability of additional undetected errors that may escape this scrutiny. These errors may affect the encryption process in unpredictable ways, possibly affecting the decryption stage and producing data loss, but will not compromise the security of the data.

##### **D1.2 SECURITY CONCERNS**

Security concerns in the areas of data privacy, authentication, access control, availability of resources, and auditing are to be addressed in higher layers and are not related to this Recommended Standard. The C&S Sublayer does not affect the proper functioning of methods used to achieve such protection at higher layers, except for undetected errors, as explained above.

The physical integrity of data bits is protected from channel errors by the coding systems specified in this Recommended Standard. In case of congestion or disruption of the link, the C&S Sublayer provides methods for frame re-synchronization.

##### **D1.3 POTENTIAL THREATS AND ATTACK SCENARIOS**

An eavesdropper can receive and decode the codewords, but will not be able to get to the user data if proper encryption is performed at a higher layer. An interferer could affect the performance of the decoder by congesting it with unwanted data, but such data would be rejected by the authentication process. Such interference or jamming must be dealt with at the Physical Layer and through proper spectrum regulatory entities.

#### **D1.4 CONSEQUENCES OF NOT APPLYING SECURITY**

There are no specific security measures prescribed for the C&S Sublayer. Therefore, consequences of not applying security are only imputable to the lack of proper security measures in other layers. Residual undetected errors may produce additional data loss when the link carries encrypted data.

#### **D2 SANA CONSIDERATION**

The current issue of this Recommended Standard does not require any action from SANA.

#### **D3 PATENT CONSIDERATIONS**

No patents are known to apply to this Recommended Standard. Information concerning patent rights and licensing for LDPC coding is contained in annex B of reference [2].

## ANNEX E

### INFORMATIVE REFERENCES

#### (INFORMATIVE)

- [E1] *Proximity-1 Space Link Protocol—Rationale, Architecture, and Scenarios*. Issue 2. Report Concerning Space Data System Standards (Green Book), CCSDS 210.0-G-2. Washington, D.C.: CCSDS, December 2013.
- [E2] *Radio Frequency and Modulation Systems—Part 1: Earth Stations and Spacecraft*. Issue 32. Recommendations for Space Data System Standards (Blue Book), CCSDS 401.0-B-32. Washington, D.C.: CCSDS, October 2021.
- [E3] *TC Synchronization and Channel Coding*. Issue 4. Recommendation for Space Data System Standards (Blue Book), CCSDS 231.0-B-4. Washington, D.C.: CCSDS, July 2021.

## ANNEX F

### ABBREVIATIONS AND ACRONYMS

#### (INFORMATIVE)

ASM Attached Synchronization Marker

C&S Coding and Synchronization

CRC Cyclic Redundancy Check

CSM Codeword Sync Marker

FIFO First In, First Out

LDPC Low-Density Parity-Check

MAC Medium Access Control

MIB Management Information Base

PLTU Proximity Link Transmission Unit

PN Pseudo-Noise

QOS Quality of Service

$R_{chs}$  channel symbol rate

$R_{cs}$  coded symbol rate

$R_d$  data rate

SANA Space Assigned Numbers Authority

USLP Unified Space Data Link Protocol