

CCSDS Spring 2026 Opening Plenary

Opening Remarks

Sami Asmar, NASA/JPL



Time	Topic	Presenter
08:30-08:40	Welcome/Logistics Overview	Sami Asmar / Amber Massaquoi CCSDS Secretariat
08:40-09:15	Introduce UPRM Admin/Keynote Remarks by UPRM	Dr. Miguel A. Muñoz, UPRM Chancellor
09:15-09:30	Keynote Remarks – NASA/SCaN	Kevin Coggins, Deputy Associate Administrator for NASA Space Communication and Navigation (SCaN) Program
09:30-09:40	Department of Commerce Perspectives	Gabriel Swiney, Acting Deputy Director, Office of Space Commerce, US Dept of Commerce (v)
09:40-09:50	CONFERS Consortium (TBC)	Jon Beam President and Chief Strategy Officer, Rogue Space Systems Corporation, Inc. Executive Committee and Board of Directors, Consortium for Execution of Rendezvous and Servicing Operations (CONFERS) (v)
09:50-10:00	CCSDS LunaNet Special Interest Group (SIG)	Daniel Pettitt Shannon Rodriguez
10:00-10:15	Break	
10:15-11:25	CESG Report and CCSDS Area Workplans	Daniel Fischer, CESG Chair Tim Pham, CESG Deputy Chair CESG Area Directors
11:25-11:40	CCSDS Technical Editor Report	Natalya Stepanova
11:40-11:50	CCSDS Group Photo	

★ Visitante2026

✧ PW:visitante@2026

Plenary Week Logistics @ CROEM

- **Up to 3 shuttles available for the week; daily schedule to be set for Tues-Fri**
- **Today's Lunch 11:50-13:30**
- **Daily Lunch at 12:00-13:00 and coffee breaks 10:00 and 15:00**
- **Group photo at conclusion of Opening Plenary session**
- **Onsite technical support for the week**
- **NASA-provided webcams available, Wi-Fi, CleverShare via Bluetooth, smartboard (via HDMI)**

UPRM hosted Dinner on Tuesday, 18:30

**Venue: College of Engineers and Surveyors of Puerto Rico –
Mayaguez**

**Address: Calle Obispado, esquina Los Ingenieros, Mayagüez, Puerto
Rico, 00680**



A New Era of Space Communications

Keynote Remarks at CCSDS Spring 2026 Meeting

Kevin Coggins

Deputy Associate Administrator

Space Communications & Navigation (SCaN)

May 25, 2026

Space Communications and Navigation

Organization Chart

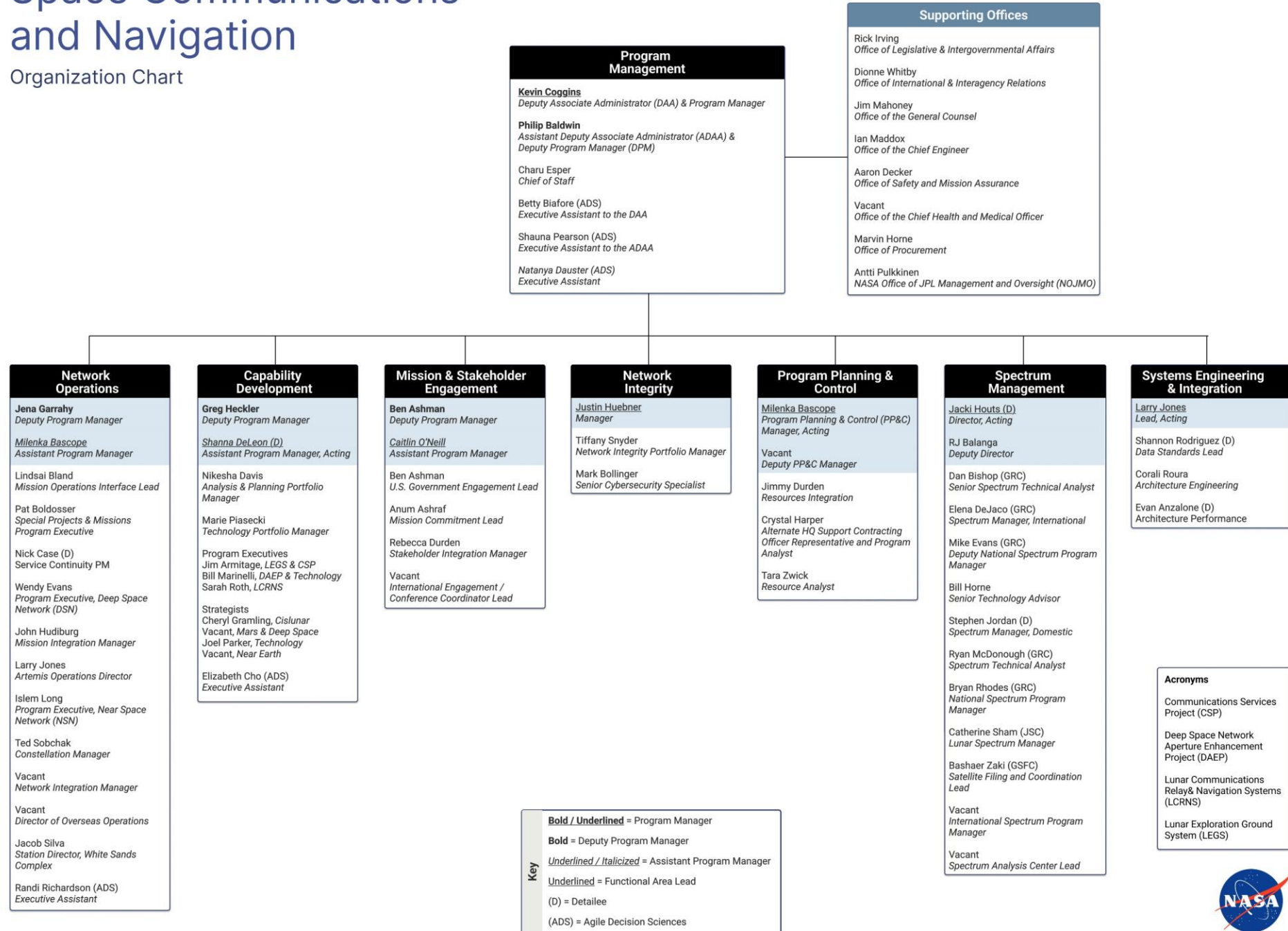



Moon to Mars Demands A New Approach

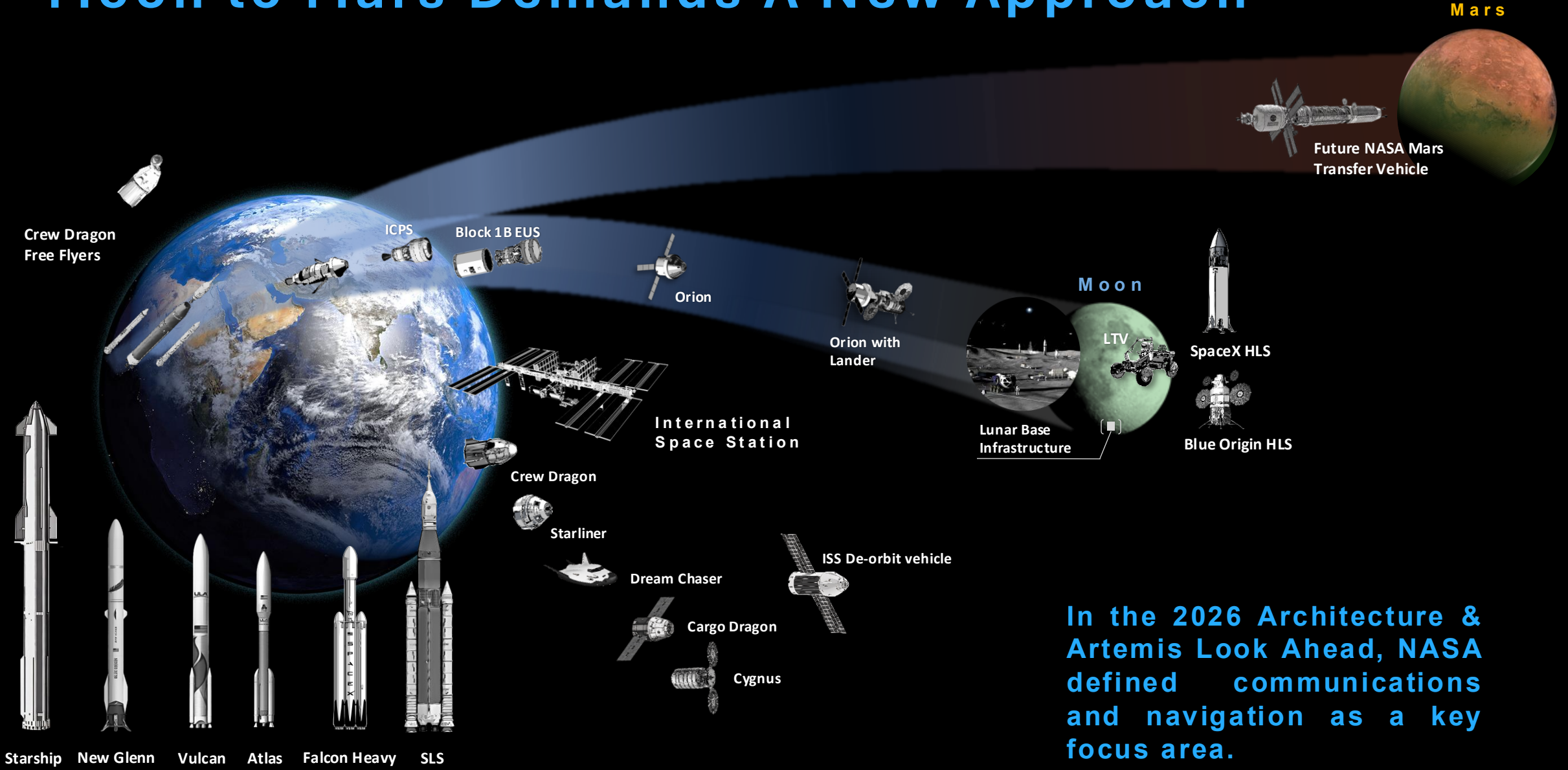

In the 2026 Architecture & Artemis Look Ahead, NASA defined communications and navigation as a key focus area.

Ignition



Replicating Earth's Infrastructure Off World

On Earth, infrastructure you don't see enables everything you do.
The Moon will be no different.



Interoperability is Key



Lunar Time

In coordination with commercial and international partners, NASA is developing Lunar Coordinated Time (LTC). This will enable a lunar ecosystem and...

- Support sustained operations at the Moon, including astronauts on the surface, autonomous vehicles, infrastructure, scientific observers, and more.
- Set a precedent for how we determine time at other celestial bodies.



We rely on extremely accurate timing to measure how long it takes a signal to travel between spacecraft and ground stations, so **even tiny timing errors can translate into large position errors over lunar distances**. LTC will increase safety among missions.

LunaNet & The Lunar Relay

LunaNet is an interoperable and scalable lunar network:

- Framework of mutually agreed-upon standards that result in a cooperative network.
- Real-time communication, data transfer, and precise navigation.
- International coordination with ESA and JAXA.
- Encourages commercial service providers and users.

NASA's Lunar Relay (LCRNS) is the first physical instantiation of the LunaNet Interoperability Specification (LNIS).



Mars Telecommunications Network

NASA is partnering with industry to create the Mars Telecommunications Network and establish a reliable communications and navigation infrastructure around Mars to support robotic and human exploration.

- Enables scalable, shared services that reduce mission complexity and support multiple users simultaneously.
- Leverages commercial partnerships and emerging technologies to accelerate capability delivery and innovation.
- Provides resilient, high-capacity connectivity needed for sustained operations and future human presence at Mars.



A Future Working Hand in Hand

NASA + INDUSTRY

COMMERCIAL

PUBLIC / PRIVATE PARTNERSHIPS

Embracing the expanding aerospace industry to bring new expertise and cost savings to users.



NASA + OGAs

INTERNATIONAL

AGENCY PARTNERSHIPS

Collaborating with national and international agencies for interoperability and security.

The Model that Got Us Here Won't Work for the Future



← THEN NOW →

Thank you!



scan@nasa.gov



nasa.gov/SCaN

SCaN

SPACE COMMUNICATIONS AND NAVIGATION



CONFERS is an industry-led standards engine

Created to turn RPO/OOS operating experience and consensus into voluntary standards.

2017/2018

DARPA mandate: technical standards for RPO/OOS safety and mission success

>80

member companies and multiple international government partners

ISO 24330

capstone RPO/OOS international standard: principles, practices, mission definition

LEO → cislunar

workspace extending from OOS to assembly and manufacturing

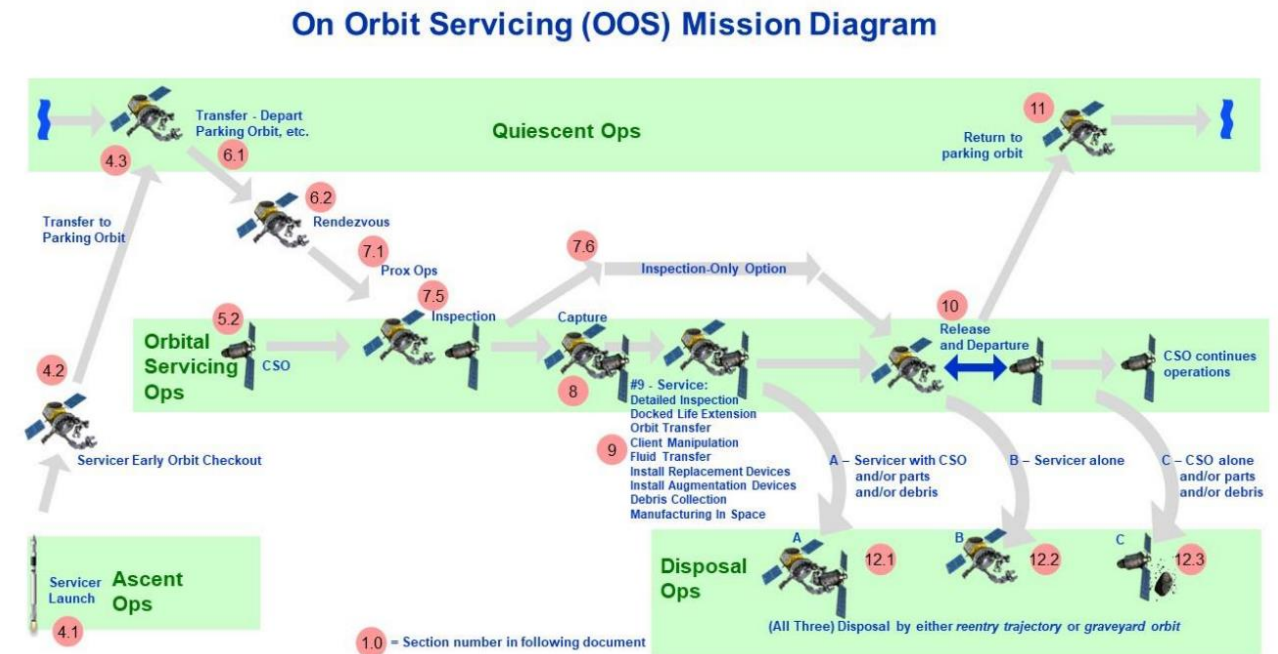

CONFERS translates operational needs into shared technical products, then routes mature products into ISO, AIAA, CCSDS, or other SDO paths as appropriate.

CONFERS began with the mission, not the interfaces

Architecture first: mission phases, lexicon, risks, operations, and client/servicer relationships.

On Orbit Servicing (OOS) Mission Diagram

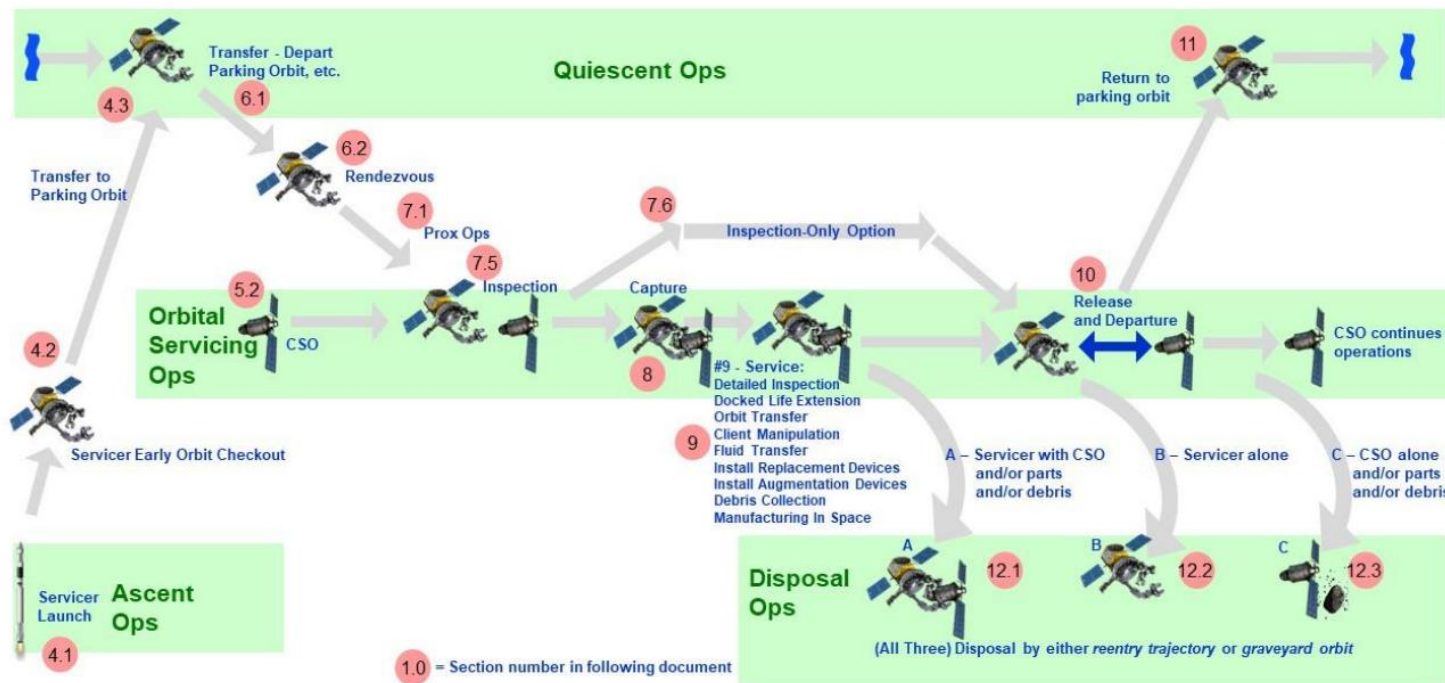

Mission phases

Rendezvous, proximity operations, inspection, capture, servicing, release, disposal.



Shared lexicon

Client space object, servicer spacecraft, prepared interfaces, and other terms of art.



Risk-to-mitigation logic

Common structure for discussing behaviors, hazards, and acceptable practices.



Standards route

High-level practices to ISO, technical interfaces to AIAA, data, communications, architecture, and security topics where CCSDS may be the right home.

Mission success starts when two teams can describe the same operation the same way.

From consensus products to voluntary consensus standards

The CONFERS technical tree connects industry work products to the right standards bodies.

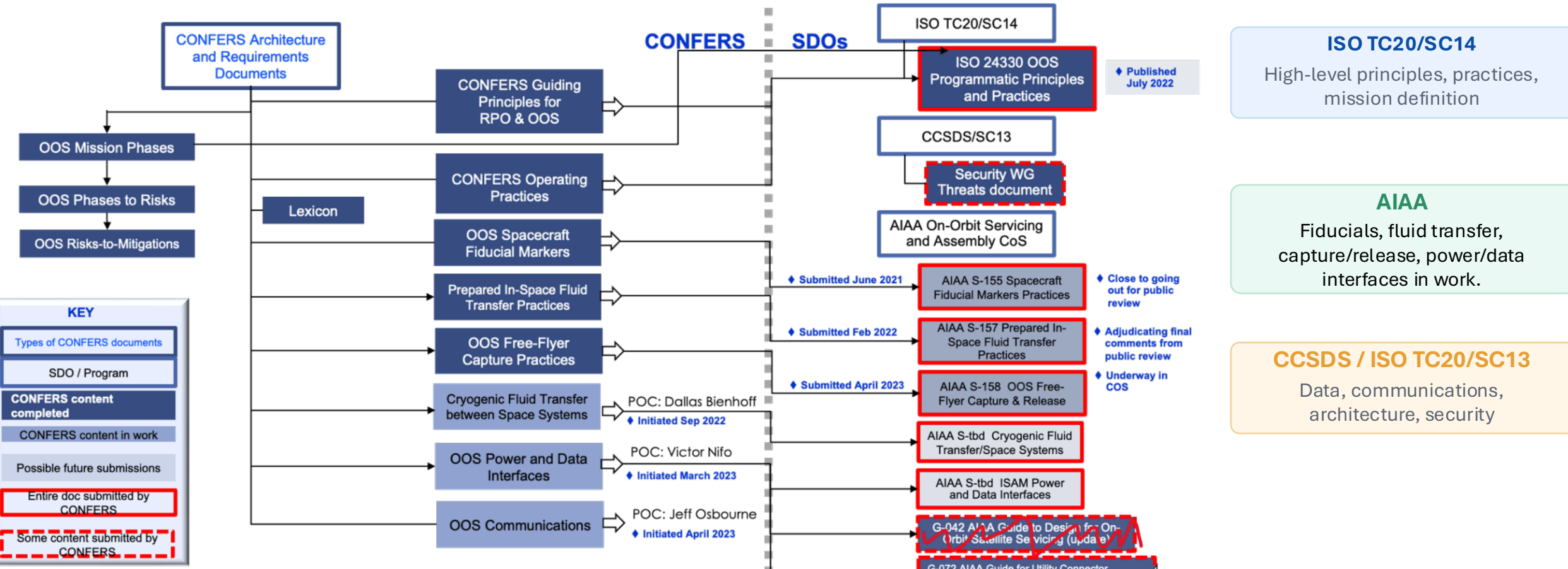

Strategic principle: choose the SDO by the maturity and nature of the work, not by “habit”.

CONFERS uses RASDS* as a standards architecture map

For RPO/OOS, the question is not only “what interface?” It is “what level of the architecture?”

* RASDS = CCSDS Reference Architecture for Space Data Systems.

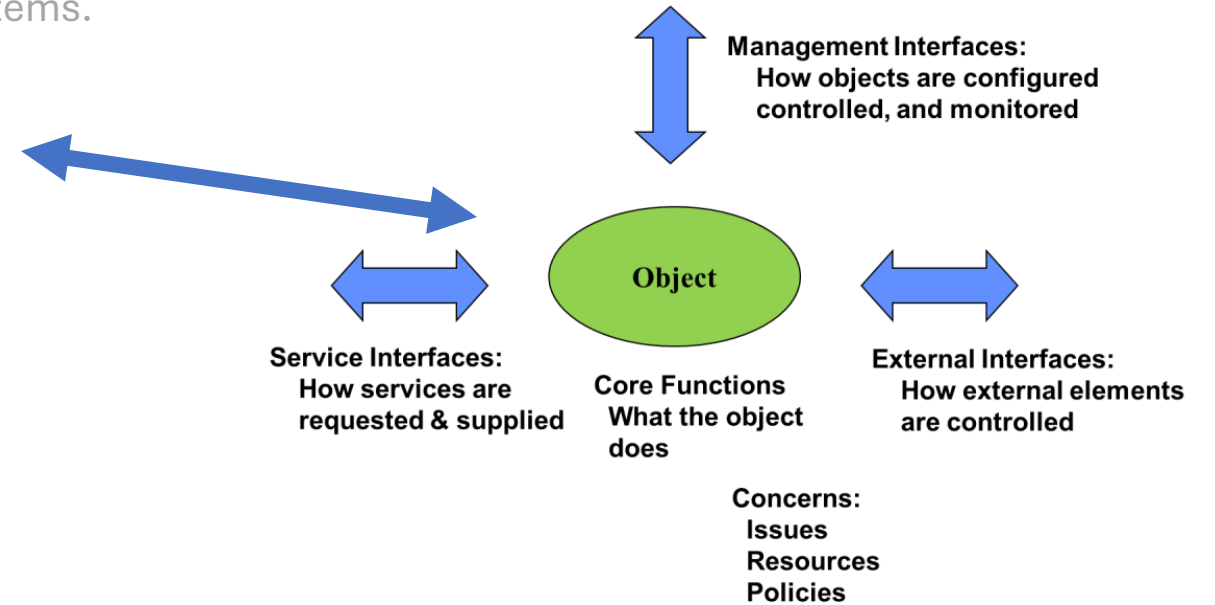
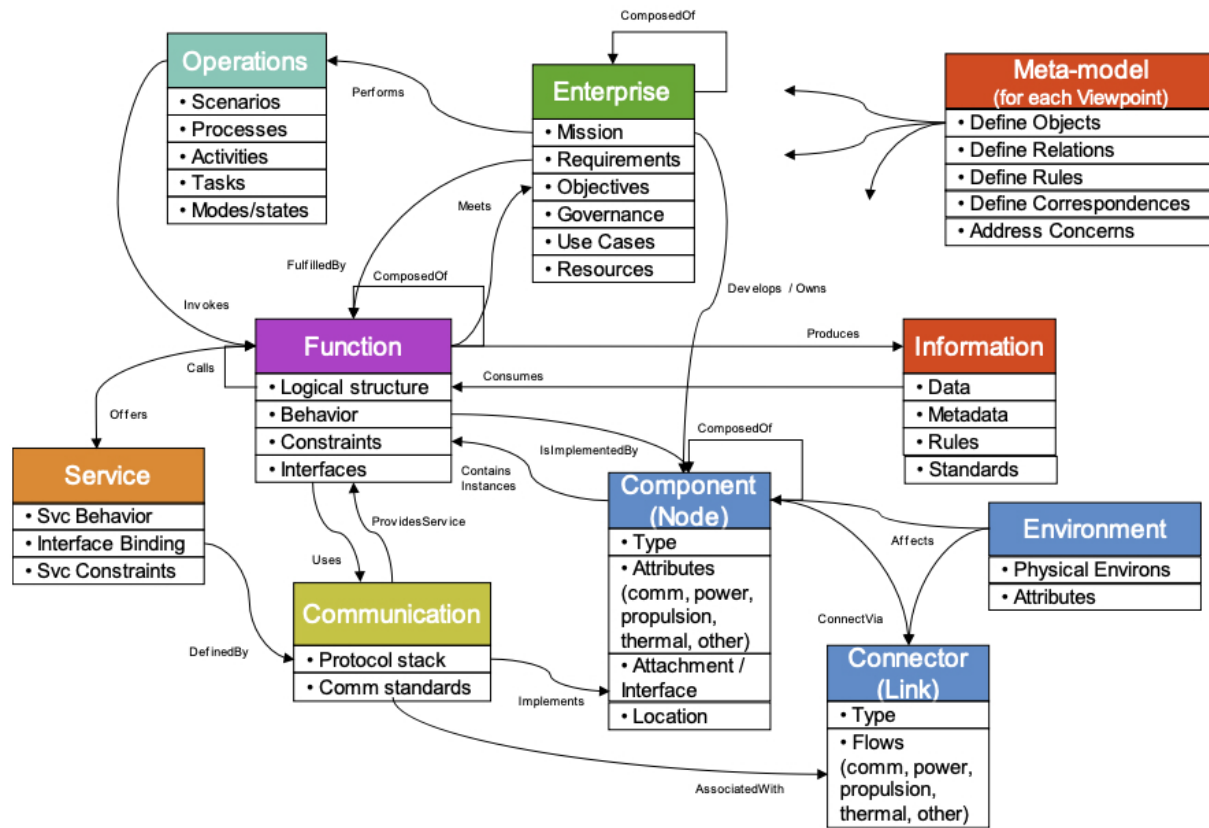

Enterprise

Mission definition, principles, governance, authority, and use cases.

Information

Lexicon, data, metadata, semantics, and rules that must remain consistent across SDOs.

Operations

Mission phases, client/servicer roles, behaviors, monitoring, and recovery.

Interfaces across views

Physical interfaces, service requests, communications paths, and verification expectations.

Interoperability is a chain, not a checkbox

CONFERS standards reduce ambiguity at each handoff between intent and execution.

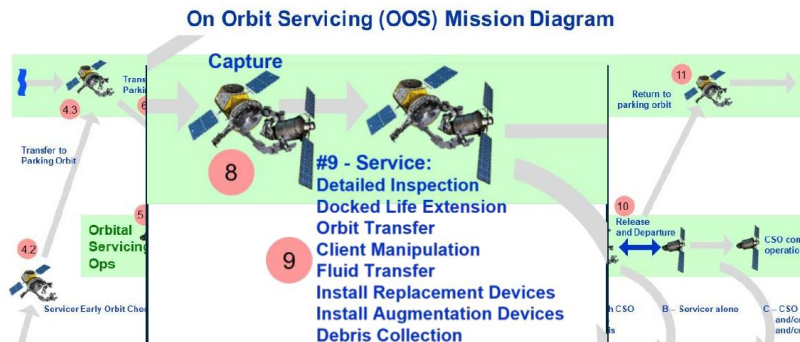
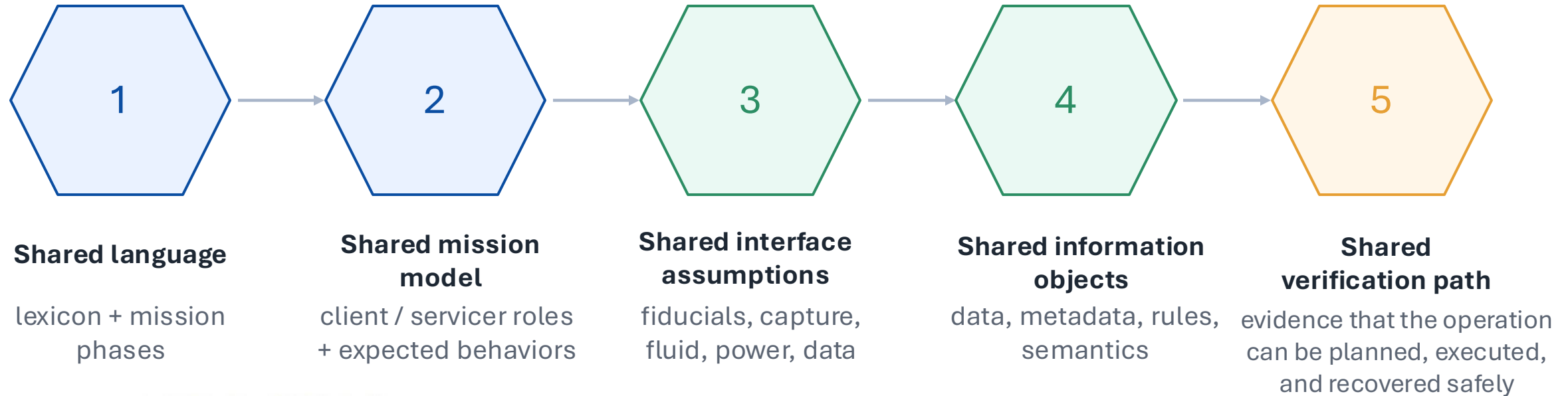

Mission success is the product of the whole chain. Breaking one link can make a technically brilliant mission operationally fragile.

Lunar, cislunar, and deep-space missions raise the interoperability bar

The standards ecosystem must span communications, operations, servicing, logistics, and information architecture.

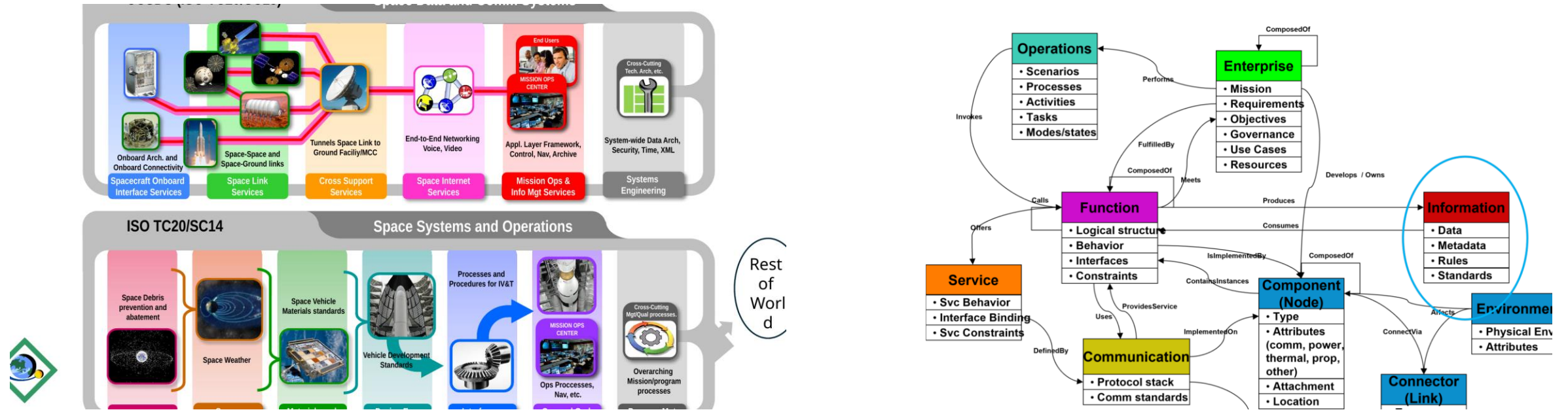

Extend OOS / ISAM assumptions beyond LEO

Keep information objects and lexicons consistent

Coordinate industry needs with ISO, AIAA, and CCSDS

For deep-space missions, the distance makes ambiguity more expensive. Standards need to be designed for delayed, disrupted, multi-operator environments, not only near-Earth convenience.

What CONFERS should keep doing

Refresh

Review architecture assumptions as the environment expands from LEO and GEO to cislunar.

Harmonize

Keep lexicons, data, metadata, and information objects aligned across SDOs.

Route

Send mature technical products to the SDO best suited for the maturity and domain.

Engage

Keep industry, government, and standards developers in the same conversation.

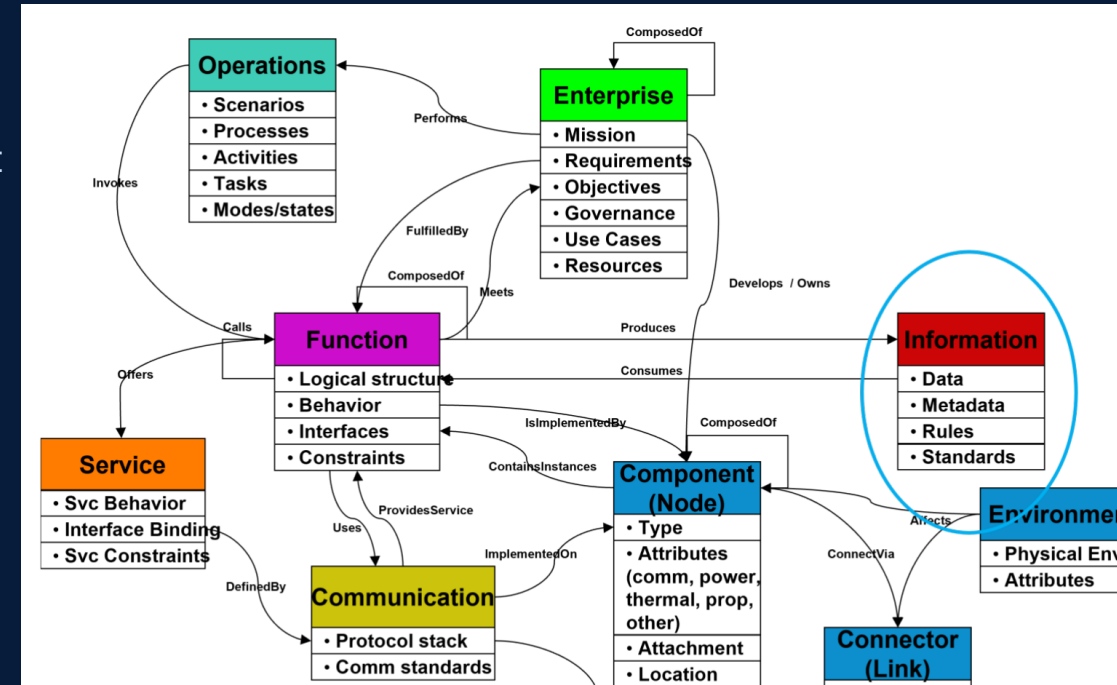

Thank you!

Common ground is not only the theme of this meeting; it is an operating condition for the next phase of the space economy.

Questions or Comments:

Please email me at: jon.beam@rogue.space

CCSDS LunaNet Special Interest Group

CCSDS Common Ground Forum, 25th May 2026

Co-chairs Shannon Rodríguez (NASA), Daniel Pettitt (ESA)

Agenda

- Overview of LunaNet SIG
- Scope and Objectives
- Delegates
- Tasks Update

CCSDS LunaNet SIG (**S**pecial **I**nterest **G**roup)

The LunaNet Special Interest Group (SIG) is established to coordinate and promote the standardization, and interoperability of communication, navigation, and networking services and technologies for lunar exploration and operations within CCSDS.

The SIG will serve as a collaborative group for CCSDS member agencies (including those that are not part of LunaNet), industrial vendors and stakeholders to align on the architecture, protocols, and services defined under the LunaNet framework.

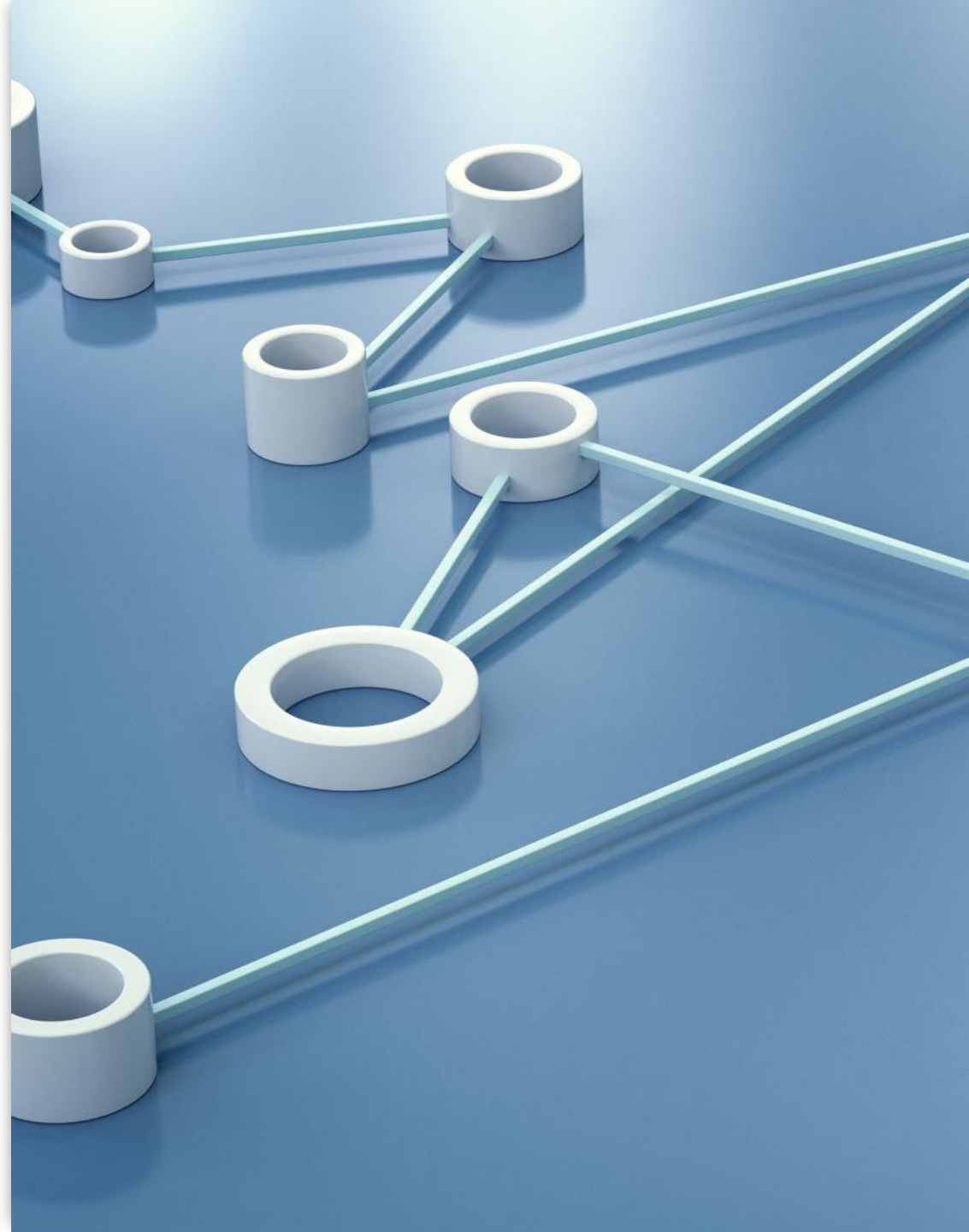

LunaNet SIG –Scope

- A. **Facilitate communication and technical exchange with the LunaNet community** via supporting the organisation and participate in the possible Interoperability Forums held at Spring and Fall CCSDS meetings.
- B. Serve as a focal point for CCSDS discussions to map and identify gaps in standards required for the LunaNet architecture and services.
- C. Support the transition of selected parts of the LunaNet Interoperability Specification (LNIS) to international CCSDS standards.
- D. Specifically draft input for a CCSDS blue book based on the technical specifications described in the LNIS AD1 Vol A (Augmented Forward Signal) and a) provide feedback on the challenges on rewriting the specifications into a CCSDS standard, and b) provide informative feedback on potential major shortcomings of the chosen technical solution.
- E. Identify and recommend areas for standardization within CCSDS for the the LunaNet ecosystem.
- F. Facilitate information exchange between CCSDS and external organizations involved in lunar networking initiatives.
- G. Coordinate with relevant CCSDS Working Groups (e.g., Space Internetworking Services, Navigation, Cross Support Services) to ensure alignment.
- H. Liason to the LunaNet implementing projects/vendors to bring in prototyping results needed for Blue Book publication (initially targeted towards AD1 Vol A).



Lunanet/CCSDS

- LunaNet is a framework for standards- based interoperable communications/network, PNT, and Alert services.
- LunaNet Interoperability Specification (**LNIS**) document set establishes the standards, protocols, interfaces for a network of interoperable networks. Complemented by a Concept of Operations.
 - Developed by the international partners in the LNIS Working Group.
 - Use existing standards (when applicable), and develop standards where needed.
 - CCSDS and any needed standards
 - Currently adopts several CCSDS Standards.
- Ongoing work with CCSDS to update specific existing standards.

CCSDS Delegates

Delegate	CCSDS WG	Agency
Daniel Pettitt	LunaNet SIG Co-Chair	ESA
Shannon Rodriguez	LunaNet SIG Co-Chair / SLS-RFM	NASA
Martin Unal	CSS-SM	ESA
Matt Cosby	SLS-SLP	UKSA
Stefano Petri	SLS-C&S	ESA
Felix Flentge	SIS	ESA
Simon Singh	SIS	NASA
Falk Schiffner	SIS	DLR
Cheryl Gramling	MOIMS-NAV	NASA
Howard Weiss	SEA-SEC	NASA
Paromita Mitra	SEA-SA	NASA
Paul Thompson	SEA-SA	UKSA

LunaNet SIG - Output



A report summarizing the LunaNet architecture and its relationship to CCSDS standards. The report shall identify which standards must be update and which new standards are needed for LunaNet including needed publication dates.



Provide feedback via an informational report to the LunaNet community on selected standards.



Potential recommendations for new BOF to initiate cross-area WG on LunaNet or a wider Solar System Internet.

Tasks Update

Review of LunaNet Signal-In-Space Recommended Standard - Augmented Forward Signal (LSIS - AFS) VOLUME A	Completed Q1 2026. <i>Consolidated comments provided to LunaNet WG</i>
Gather LunaNet WG needs list towards CCSDS	Completed Q1 2026.
Review and prioritization of LunaNet WG Needs List	Ongoing <i>On Agenda for CCSDS Spring Meeting</i>
CCSDS organization considerations to address LunaNet needs	<i>On Agenda for CCSDS Spring Meeting</i>
Identify gaps in standards required for the LunaNet architecture and services.	Planned Q2-Q3 2026
Identify prototyping opportunities	Planned Q2-Q3 2026
Generate SIG output report on LunaNet standards and relationship to the architecture, including recommendations to CCSDS	Planned Q4 2026 – Q1 2027
Generate informational report for LunaNet WG	Planned Q4 2026 – Q1 2027

CCSDS Spring 2026 Opening Plenary

CCSDS Engineering Steering Group (CESG) Report

Daniel Fischer (ESA), Timothy Pham (NASA/JPL)



CCSDS Areas

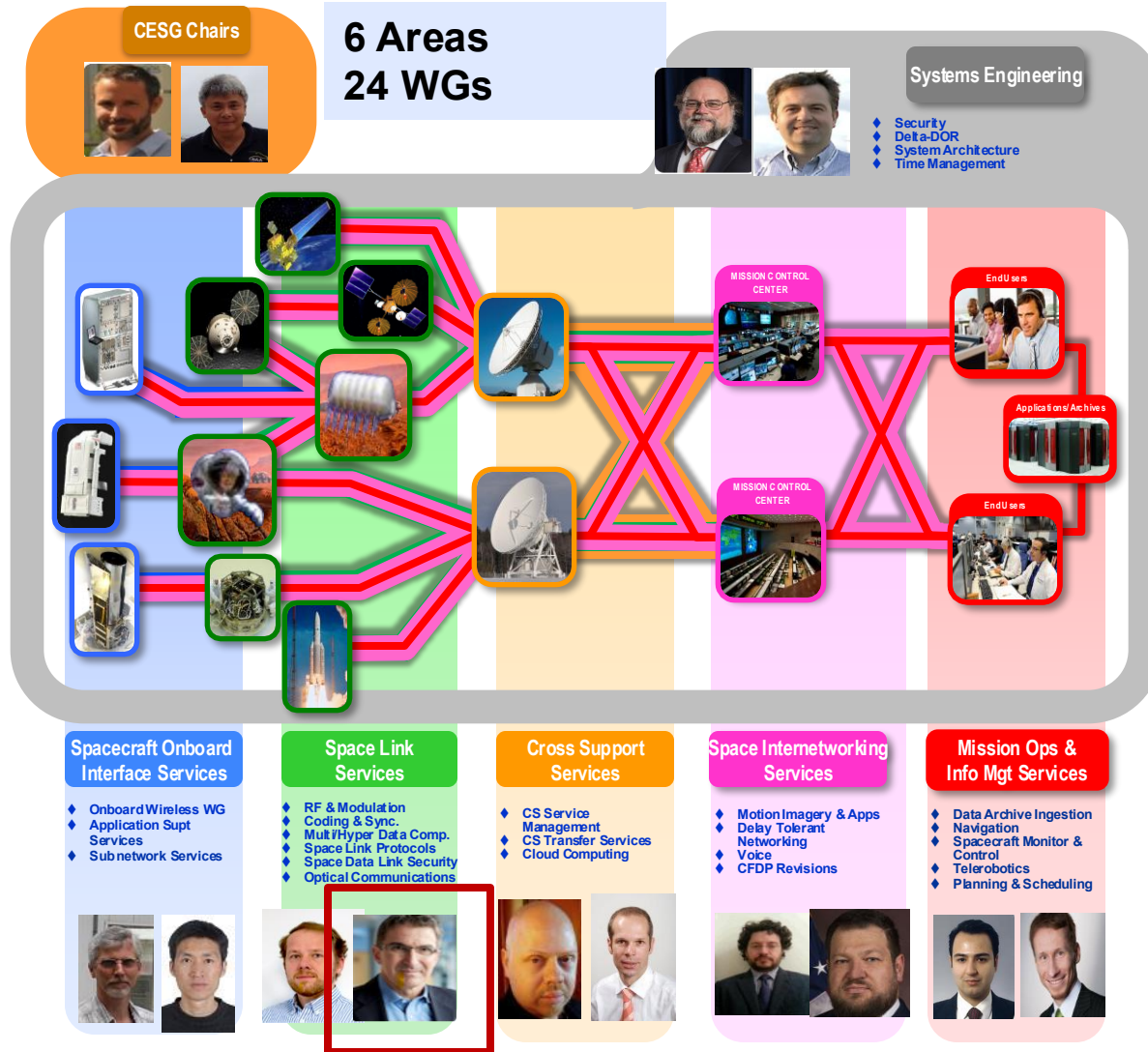

CESG Chair
Deputy

Daniel Fischer
Timothy Pham

SEA Area Director
Deputy

Jim Lux
Matthew Cosby

MOIMS Area Director
Deputy

Mehran Sarkarati
Stefan Gärtner

CSS Area Director
Deputy

Erik Barkley
Holger Dreihahn

SLS Area Director
Deputy

Clemens Heese
Jean-Luc Issler

SIS Area Director
Deputy

Tomaso de Cola
'Vinny' Ivica Ristovski

SOIS Area Director
Deputy

Simon Singh
Xiongwen He

Blue Books – Recommended Standards

- ✦ CCSDS 131.0-B-6 : TM Synchronization and Channel Coding (Issue no:6, April 2026).
- ✦ CCSDS 142.0-B-2 : Non-Coherent Optical Communications Coding and Synchronization (Issue no:2, March 2026).
- ✦ CCSDS 141.0-B-2 : Non-Coherent Optical Communications Physical Layer (Issue no:2, March 2026).
- ✦ CCSDS 734.1-B-1 Cor. 1 : Technical Corrigendum 1 to CCSDS 734.1-B-1 Licklider Transmission Protocol (LTP), Issued May 2015 (Issue no: 1 Cor. 1, February 2026).
- ✦ CCSDS 732.0-B-5 : AOS Space Data Link Protocol (Issue no:5, March 2026).

Approval to publish:

- ✦ CCSDS 529.1-B-1, Mission Operations—Mission Planning and Scheduling Services (Blue Book, Issue 1)
- ✦ CCSDS 231.0-B-4 Cor. 1, Technical Corrigendum 1 to 231.0-B-4, Issued September 2025
- ✦ CCSDS 722.1-M-2, CFDP Unitdata Transfer Layers (Magenta Book, Issue 2)
- ✦ CCSDS 734.6-O-1, Custody Transfer and Compressed Bundle Status (Orange Book, Issue 1)
- ✦ CCSDS 131.0-B-6, TM Synchronization and Channel Coding (Blue Book, Issue 6)
- ✦ CCSDS 902.12-M-2, Cross Support Service Management—Common Data Entities (Magenta Book, Issue 2).
- ✦ CCSDS 902.9-B-1, Service Management Utilization Request Formats (Blue Book, Issue 1).
- ✦ CCSDS 902.4-B-1, Cross Support Service Management—Service Package Data Formats (Blue Book, Issue 1).
- ✦ CCSDS 142.0-B-2, Non-Coherent Optical Communications Coding and Synchronization (Blue Book, Issue 2).
- ✦ CCSDS 734.1-B-1 Cor 1, Technical Corrigendum to CCSDS 734.1-B-1, Issued May 2015

Approval to release for Agency Review:

- ✦ CCSDS 211.0–B-6, Proximity-1 Space Link Protocol—Data Link Layer (Blue Book, Issue 6, July 2020);
- ✦ CCSDS 211.1–B-4, Proximity-1 Space Link Protocol—Physical Link Layer (Blue Book, Issue 4, December 2013);
- ✦ CCSDS 211.2–B-3, Proximity-1 Space Link Protocol—Coding and Synchronization Sublayer (Blue Book, Issue 3, October 2019);
- ✦ CCSDS 902.11-R-1, Cross Support Service Management–Best Practices (Red Book, Issue 1)

New Working Group

- ✦ LunaNet Special Interest Group (SLS-LUNANET)

New Appointments:

- ✦ Chair : The Data Compression Working Group (SLS-DC) - Aaron Kiely (NASA)
- ✦ Deputy Chair: MOIMS-Navigation Working Group (MOIMS-NAV) - Frank Budnik (ESA)
- ✦ Deputy Chair: Time Management Working Group (SEA-TIME) - Yukio Yamamoto (JAXA)
- ✦ NASA Agency Delegate to the CMC - Shannon Rodriguez (NASA)

CESG Actions Report

- CCSDS/ LunaNet SIG started up work (Co-Chairs: Shannon Rodriguez (ESA), Daniel Pettitt (ESA))
- Ongoing review of CCSDS Procedures (CCSDS A02.1-Y-4 Organization and Processes for the Consultative Committee for Space Data Systems)
 - Propose streamlining and increased standards development efficiency where possible
 - Currently testing some of the proposed changes (e.g. approval loop streamlining, editor queue prioritisations, etc.)
 - Lead: Clemens Heese, Matt Cosby
- Review of the IOAG/CCSDS Product Agreement
 - Objective: Focus on development of standards needed by future missions
- Update of the CCSDS Management Framework: Adding new features to support WGs in standards development (ongoing)
- Expanded involvement of industry in CCSDS activities, including a new approach to interoperability testing
- Review of CCSDS strategic plan

CCSDS Resources

				NASA						ESA						CNES						DLR						OTHER										
Area	WG	C	Co	BB	P1	P2	GB	MB	OB	BB	P1	P2	P3	GB	MB	YB	OB	BB	P1	P2	P3	GB	MB	BB	P1	P2	GB	MB	OB	BB	P1	P2	GB	MB	OB			
SEA	SA	NASA					1	1																														
SEA	Security	NASA	ESA				3	2		1	1			2	1																				1		MB=UKSA	
SEA	Time	NASA	ESA				1																															
SEA	D-DOR	ESA	NASA			1		2		1	1			1																								P3=JAXA
MOIMS	DAI	UKSA	NASA		1			1				1														1						1	1				GB, BB, MB=UKSA	
MOIMS	NAV	NASA	ESA	4	5						1	4						1	1						1						2						BB, P2=UKSA, other	
MOIMS	SM&C	ESA	NASA							3	3	1		1				1	1	2						1		1										
MOIMS	MP&S	ESA	CNES							1	1			1	1											1												
CSS	SM	NASA	ESA	1		1				1	1	1	1		1										1	2	1		1			1					OB, P1=UKSA	
CSS	CSTS	ESA		3	1					1		1																										
CSS	CDDS	ESA	NASA		1	1								1																								
SOIS	APP	NASA	UKSA						1																													
SOIS	WIR	NASA	FSA				1		1																1						1						P2=JAXA	
SOIS	SNW	NASA	ESA					5																														
SLS	RFM	ESA	NASA	2	1	1				1	2	1					1																					
SLS	C&S	ESA	NASA	1	1	3				3	4	1		2			1																					
SLS	MHDC	NASA	ESA	1	1	2				1	1			1							2																	
SLS	SLP	NASA	UKSA	6	2		2	1				1																				1					P2=UKSA	
SLS	SDLS	CNES	NASA	1						1	2																											
SLS	OPT	NASA	ESA	3	2	1					1	4		1											2					1							OTHER=JAXA	
SIS	MIA	NASA	DLR	1		1	2																		1													
SIS	DTN	NASA	JAXA	3	5		1		6		2	2				1	2									1			1									
SIS	VOICE	DLR	FSA																																			
SIS	CFDP	ESA	UKSA							1					1																							
				26	20	11	11	12	8	15	20	17	1	10	4	1	4	2	2	2	2	0	0	1	6	4	0	2	1	3	1	4	1	2	1		194	
				88 % 45.36						72 37.11						8 4.12						14 7.22						12 6.19 CNSA, UKSA, AFRL, FSA, Japan, JAXA, NASA										
																																						194

Area Directors / Deputy Area Directors - Overview

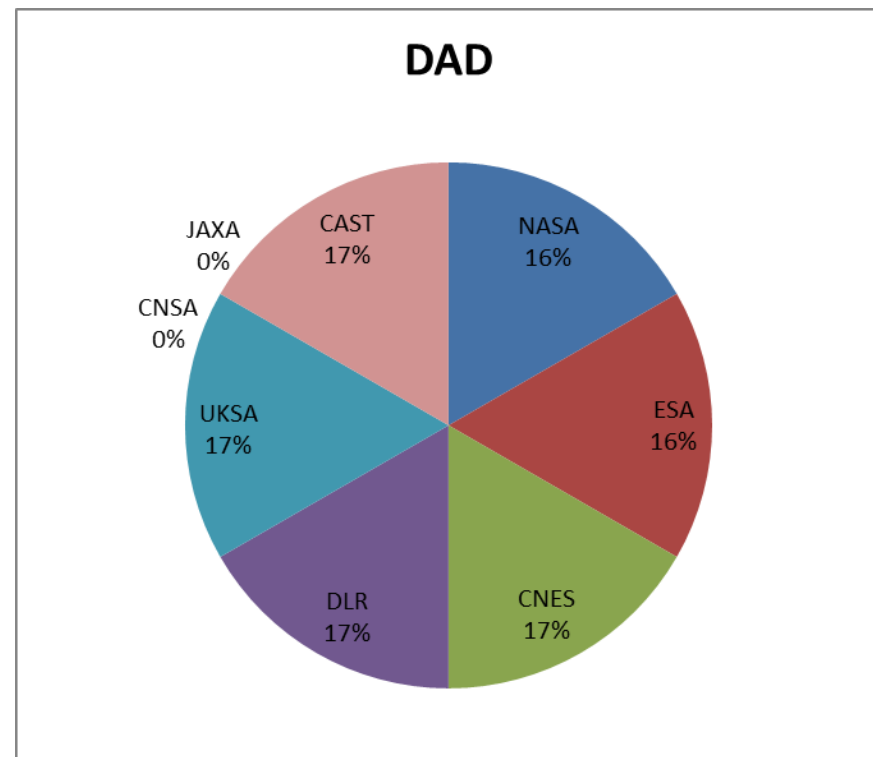
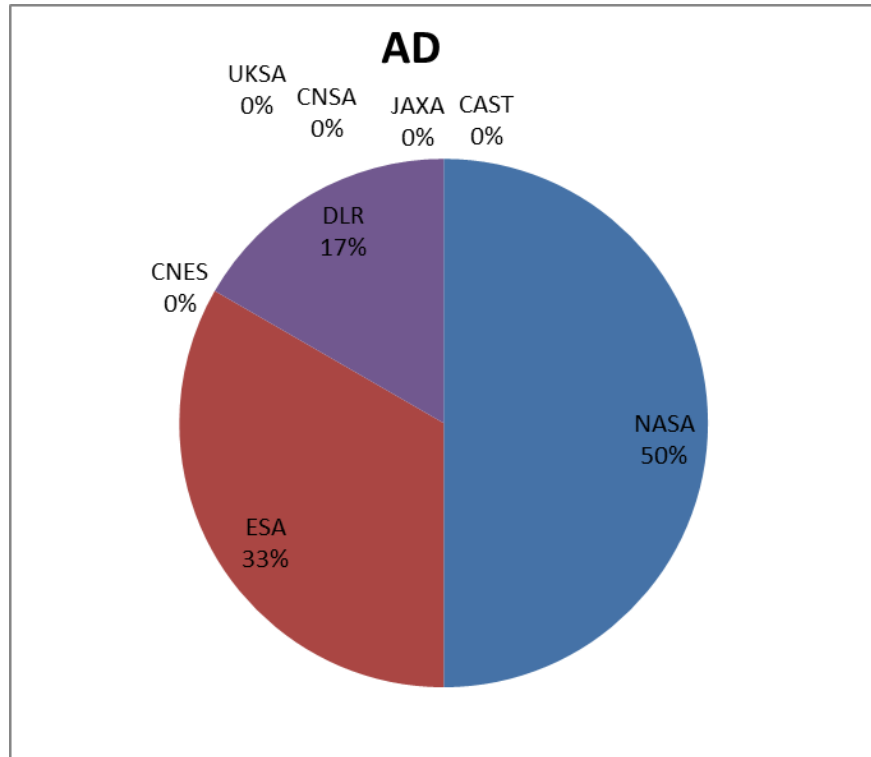

	AD	DAD
NASA	3	1
ESA	2	1
CNES		1
DLR	1	1
UKSA		1
CNSA		
JAXA		
CAST		1
Total	6	6

WG Chair / Deputy Chair - Overview

Area	WG	C	Co
SEA	SA	NASA	UKSA
SEA	SEC	NASA	ESA
SEA	Time	ESA	JAXA
SEA	D-DOR	ESA	NASA
MOIMS	DAI	UKSA	NASA
MOIMS	NAV	NASA	ESA
MOIMS	SM&C	CNES	NASA
MOIMS	MP&S	ESA	0
CSS	SM	NASA	DLR
CSS	CSTS	DLR	0
CSS	CDDS	ESA	NASA
SOIS	APP	NASA	UKSA
SOIS	WIR	NASA	FSA
SOIS	SNW	NASA	ESA
SLS	RFM	NASA	ESA
SLS	C&S	ESA	NASA
SLS	MHDC	NASA	ESA
SLS	SLP	NASA	UKSA
SLS	SDLS	CNES	NASA
SLS	OPT	NASA	ESA
SIS	LUNANET	ESA	NASA
SIS	MIVA	DLR	NASA
SIS	DTN	NASA	ESA
SIS	CFDP	ESA	UKSA

	WG Chair	WG Deputy Chair
NASA	12	8
ESA	7	7
CNES	2	0
DLR	2	1
UKSA	1	4
JAXA	0	1
FSA	0	1
Total	24	22

WG CHAIR

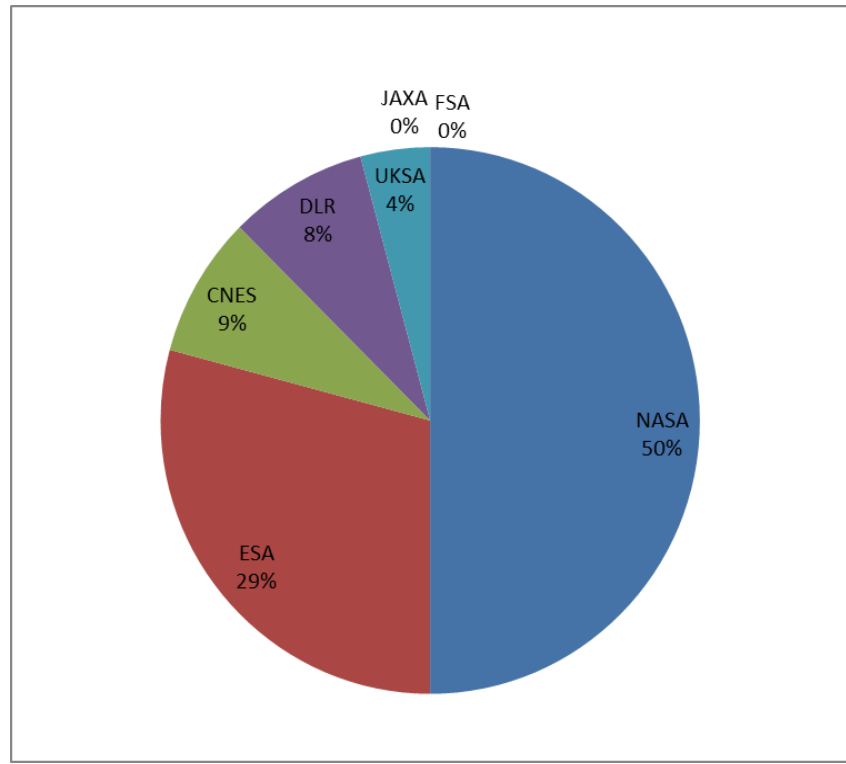

WG DEPUTY CHAIR

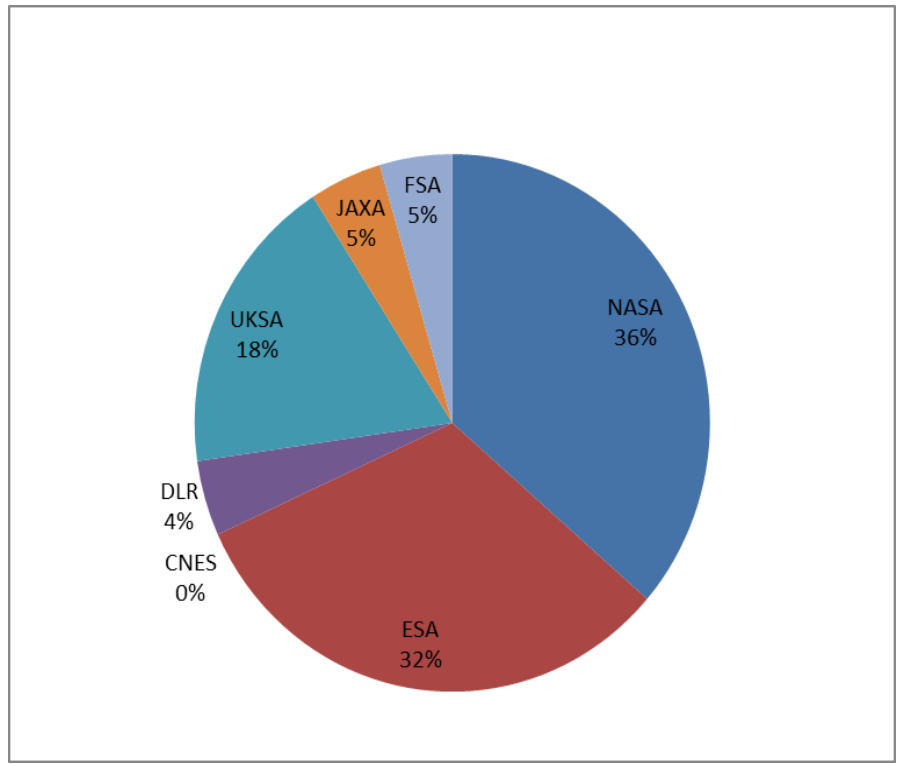

CCSDS Fall 2026 Meetings



**Technical Meetings:
19-23 Oct 2026**

**CESG/CMC Meetings:
26-28 Oct 2026**

**Location: CTE - Casa
delle Tecnologie
Emergenti**

Matera - How to get there?

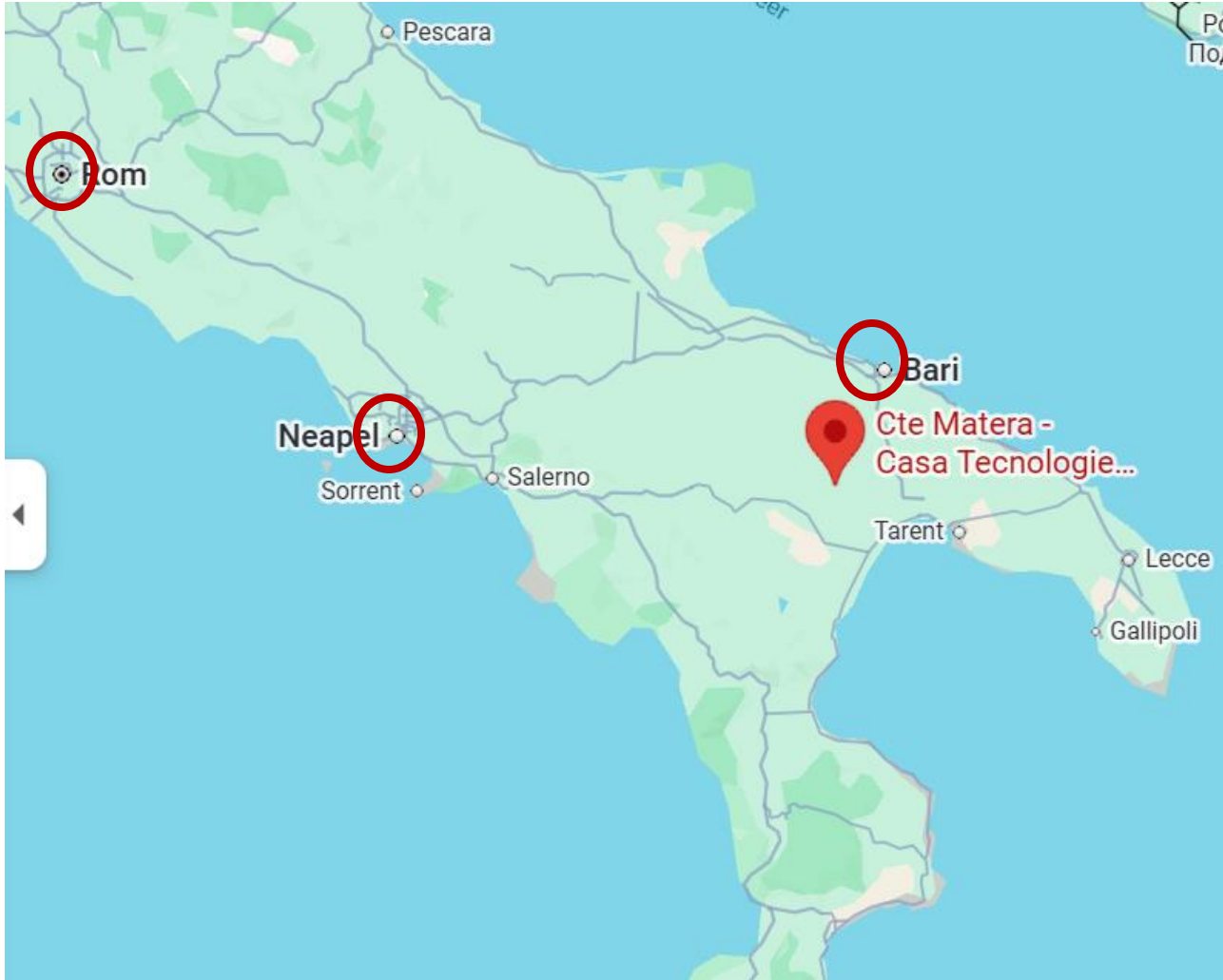

✦ **Three possible airports:**

- ✧ **Rome: 5 hrs drive**
- ✧ **Naples: 3 hours drive**
- ✧ **Bari: 1 hr drive**

✦ **ASI is currently preparing hotel recommendations**

CCSDS Plenary Spring 2026 Area Report

Systems Engineering (SEA) Area

Jim Lux (NASA/JPL), Matt Cosby (UKSA)



- **Interoperability is everywhere**
- **Moving well beyond stovepipes to networks of networks**
 - **DTN, LunaNet, etc.**
- **How do we transfer time?**
- **How do we describe the architectures**
- **How do we do security**
- **How do we do multi spacecraft navigation**

- **Systems Architecture WG**
 - Review plan to update SCCS-ADD (Arch Descr Doc) to complement ARD (Arch Ref Doc)
 - Updates to ARD MB
 - RASDS application and proposal for technology alignment
 - Participate in LunaNet SIG, Joint meeting with Security and SIS-DTN
- **DeltaDOR WG**
 - Review demo of multi agency multi spacecraft (Earlier this month)
 - Consider updates for DDOR Ops MB
 - Start refurbishing GB
 - Time Management WG
 - Review Time Transfer MB progress
 - Time Code Format interoperability YB
 - Revise Time Management GB, to include DTN, Relay, future architectures
- **Security WG**
 - Review revs to Crypto Algorithm BB (Post Quantum Safe Algorithms)
 - Review changes to Layering GB (description of bulk encryption)
 - Meet with DTN - security issues
 - Meet with Arch WG - security architecture directions

- **Architecture**
 - Initial draft of RASIM and SCCS-ARD
 - Align Application and terminology
 - Working with LunaNet and other
- **DDOR**
 - Big demo in May with multiple agencies (DSN,ESA, JAXA) and 4 SC (Psyche, MRO, Odyssey, TGO)
 - Didn't meet in person in 2025
- **Time Management**
 - Establishing list of reference epochs
 - Time Transfer
- **Security**

CCSDS Plenary Spring 2026 Area Report

Mission Operations and Information Management Area (MOIMS)

Mehran Sarkarati (ESA), Stefan Gärtner (ESA)



● Navigation WG (NAV)

- **Issues: Several projects "behind schedule", Moderate progress**
- **BB: 503.0 Tracking Data Message (TDM - NASA, ESA): 5y revision** Internal WG Review ongoing
- **BB: 505.0 Navigation Data Message XML Specs (NDM - no prototype): 5y revision** AR completed, Testing deferred temporarily
- **BB: 508.0 Conjunction Data Message (CDM): 5y revision** AR completed, Tests 75% complete
- **BB: 507.1 Launch Data Message** White Book 1.0 Drafting in progress
- **BB: 508.2 Fragmentation Data Message** White Book 1.0 Drafting in progress
- **BB: 5xx.x Navigation Composite Data Message** White Book 1.0 Drafting in progress
- **BB: 507.0 Navigation Events Message (NEM)** White Book 1.0 Drafting in progress
- **GB: 500.0 Navigation Data – Definitions and Conventions** Discussions with SANA for adoption

● Spacecraft Monitor & Control WG (SM&C)

- **Issues:**
 - > **Difficulties to progress correctly due to restrictions of time and budget allocated to standardization in all agencies**
 - > **Bottleneck in the Tech Editor Queue: books are stuck there**
- **BB: 521.0 Mission Operations - Message Abstraction Layer (MAL) (ESA, CNES)** Published
- **BB: 522.1 Mission Operations - Mission Operations Monitor & Control Services** Prototype ongoing
- **BB: 524.3 MO--MAL Binding to HTTP Transport and XML Encoding (ESA, ?)** **Stuck in Tech Editor Queue** before AR
- **BB: 524.1 MO--MAL Space Packet Transport Binding and Binary Encoding (PS)** Drafting
- **GB: 520.0 MO Services Concept (ESA): 5y revision** WG internal review
- **MB: 520.1 Mission Operations Reference Model (DLR): 5y revision** **Stuck in Tech Editor Queue** before AR
- **BB: 522.2 Mission Product Data Distribution Services (ESA, CNES)** **Stuck in Tech Editor Queue** before publication
- **BB: 522.x File Management Services (ESA, ?)** On-hold
- **New project envisaged for CCSDS Delivery Agent** Cancelled: no clear need at this point

● Data Archive Interoperability WG (DAI)

- **Issues:** Issue with the URLs, Good progress
- **MB:** 671.0 Open Archive Information Systems Interoperability Framework (OAIS-IF) Architecture Description
- **BB:** OAIS-IF Core Specification
- **GB:** OAIS-IF Rationale, Scenarios and Requirements

Drafting
Drafting/almost ready for AR
Drafting

● Mission Planning & Scheduling WG (MP&S)

- **Issues:** deputy-chair position vacant (JPL Candidate - Chet Joswig)
- **BB:** 529.1 Mission Planning and Scheduling Services (ESA, DLR)
- **MB:** 529.2 Mission Planning and Scheduling Information Model
- **GB:** 529.0 Mission Planning and Scheduling (Issue 2): 5y revision

In Publication Queue
Internal WG Review ongoing
Drafting

CCSDS Plenary Spring 2026 Area Report

Cross Support Services Area (CSS)

Erik Barkley (NASA/JPL), Holger Dreihahn (ESA/ESOC)



Cross Support Services Area Main Items and Preview

- Highlights since last meeting:
 - CSSM WG (Service Management) – Agency review initiated for SM Best Practices (MB); CESG publication polling completed for Service Request and Service Package Data Formats (both BBs)
 - CSTS WG (X-Support Data Transfer) – SC-CSTS (BB) submitted for polling for agency review
 - CDDS WG (Cloud Data Deliver) – Experimental Specification (OB) advanced re implementation of Cloud Data Delivery Standard based on advanced draft BB; Concept Book (GB) advanced to AD review



CDDS – Cloud Data Delivery Standards

- Finalize Concept (GB) book for publication polling
- Progress Blue Book and Orange Book
- Develop prototype plan

CSSM – Cross Support Service Management

- Agency review coordination for Best Practices (MB)
- API (OB) development for managing services
- Determine status/plan re Service Agreement and Configuration Profile re polling for agency review

CSTS – Cross Support Transfer Services

- Release Service Control (standard for real-time MOC <- -> GS communications related to control of GS services) for agency review
- Look at inclusion of functional resource and parameter related to Optical Comm into the Functional Resource Model

Area Level

- Contribute to SIS,SE, CSS Areas joint session on DTN
- Develop Area-level policy re use of Github repositories and public availability

Space Link Extension – the (aging) Granddaddy success story

- Addresses how to transfer data to/from agency ground stations
- Supported many missions; most widely implemented are Return All Frames (Telemetry – CCSDS 911.1) and Forward Command Link Transmission Unit (Telecommand – CCSDS 912.1)
- Implemented across several agencies
 - ASI, CNES, CNSA, DLR, ESA, INPE, ISRO, JAXA, NASA, Roscosmos
- Commercial providers as well
 - SSC, KSAT, GES
- However, SLE has evolutionary hurdles
 - Cloud Data Delivery leverages SLE PDUs to bring forth a more modern, scalable standard

Simple Schedule Format (CCSDS 902.1)

- Addresses how to express schedule of services for ground stations and mission spacecraft
- Implemented at following
 - Agencies: DLR, ESA, NASA
 - Commercial Providers: GES, KSAT
- In the process of implementing
 - Agencies: CNES, JAXA
 - Commercial Providers: SSC

CCSDS Plenary Spring 2026 Area Report

Spacecraft Onboard Interface Services (SOIS) Area

Simon Singh (NASA/GSFC), Xiongwen He (CAST)



Application Support WG

- Interoperability testing 876.0-P-1.1 XML Specification has resumed
 - Book was updated to incorporate feedback from mission users
- Ongoing and productive discussions with agency and industry mission engineers to infuse SOIS standards
 - cFS is big user of SEDS
- Ongoing discussion with Artemis Program and missions on new standard for software component and device configuration objects
- Meeting Objectives
 - Review interoperability tests
 - Support meetings with DTN and CSS area
 - Discuss first hop/last hop application standard for DTN
 - Review of Network Management needs with LunaNet and Mars Programs

Artemis is Using XTCE and SOIS Electronic Data Sheets



CCSDS SOIS Electronic Data Sheets

CCSDS
The Consultative Committee for Space Data Systems

Recommendation for Space Data System Standards

SPACECRAFT ONBOARD INTERFACE SERVICES—XML SPECIFICATION FOR ELECTRONIC DATA SHEETS

RECOMMENDED STANDARD
CCSDS 876.0-B-1

BLUE BOOK
April 2019

CCSDS
876.0-B-1
SEDS

CCSDS
876.1-R-2
SEDS
DoT

CCSDS
The Consultative Committee for Space Data Systems

Draft Recommendation for Space Data System Practices

SPACECRAFT ONBOARD INTERFACE SERVICES—SPECIFICATION FOR DICTIONARY OF TERMS FOR ELECTRONIC DATA SHEETS

DRAFT RECOMMENDED PRACTICE
CCSDS 876.1-R-2

RED BOOK
June 2016

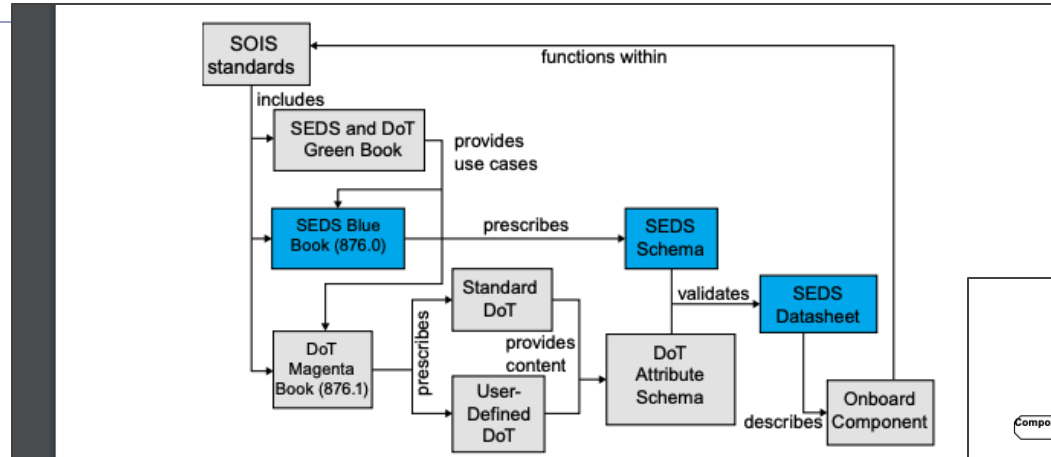

Figure 2-1: SEDS Concept Map

A SOIS Electronic Data Sheet (SEDS) specifies the usage of SOIS standards by an Onboard Component. The XML schema used to validate such a datasheet is defined in two parts:

- The SEDS Schema is defined and described in this document.
- The DoT Attribute schema is extensible and comes from combining the standard and, optionally, a user-defined Dictionary of Terms (DoT), as described in reference [1].

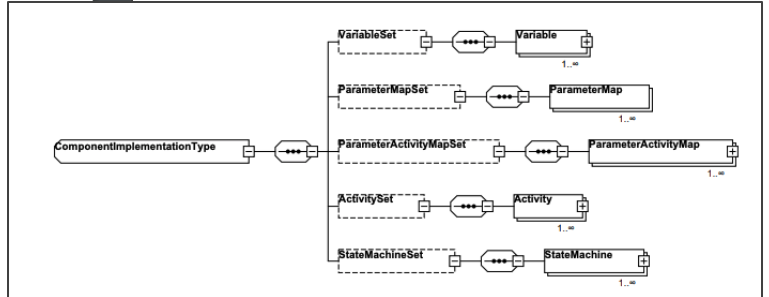
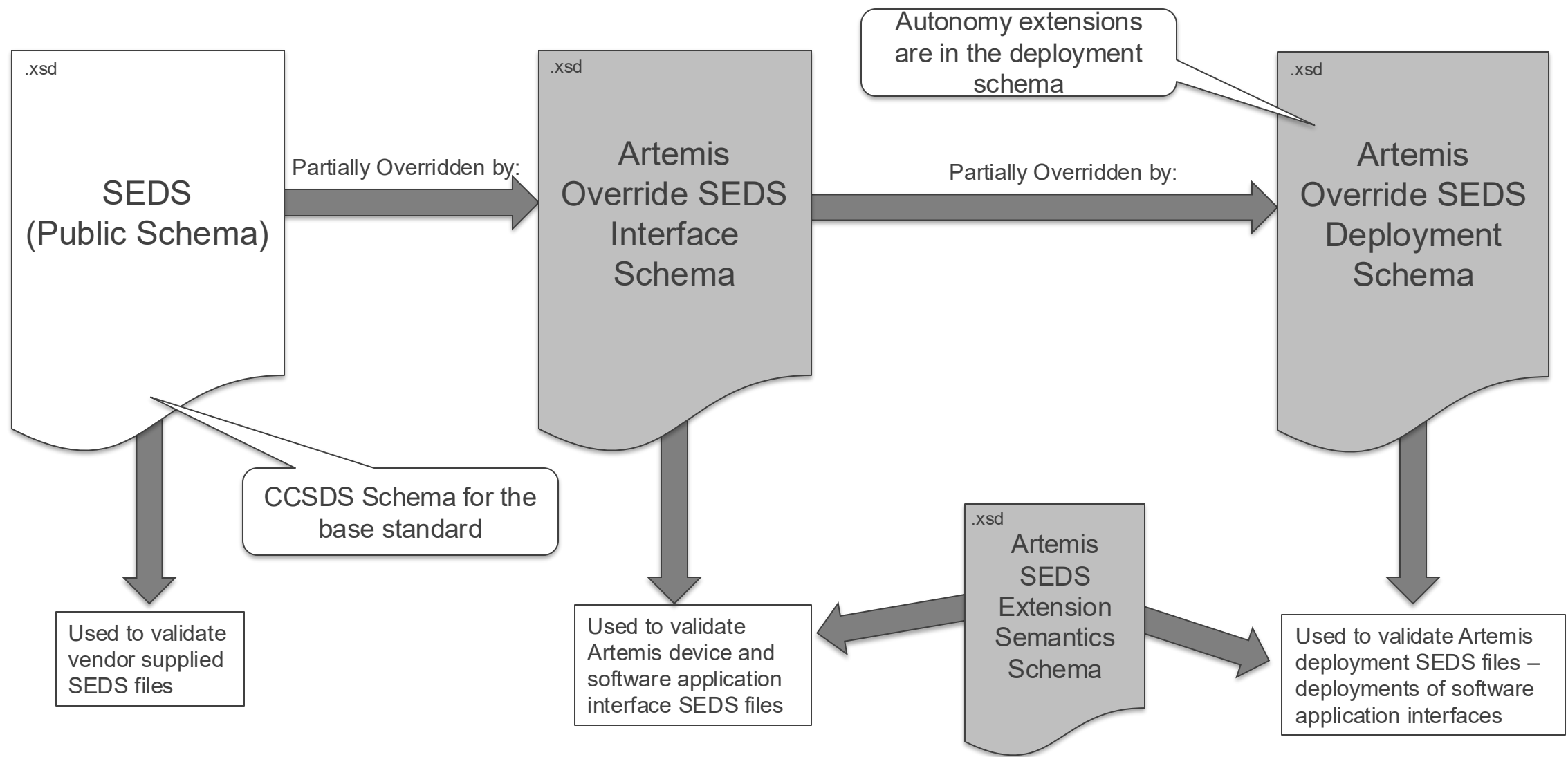

Table 3-1: Data Types, Encodings, Ranges, and Literals

Data Type	Encoding Type	Range Types	Literal Syntax
BinaryDataType			xs:hexBinary
BooleanDataType	BooleanDataEncoding		xs:boolean
EnumeratedDataType	IntegerDataEncoding	EnumeratedRange	xs:string, matching enumeration label.
FloatDataType	FloatDataEncoding	PrecisionRange MinMaxRange	xs:float
IntegerDataType	IntegerDataEncoding	MinMaxRange	xs:integer
StringDataType	StringDataEncoding		xs:string
SubRangeDataType		as base type	as base type, within range

Artemis SEDS Schema



✦ File size:

- ✧ SEDS files due to their structure generally create much smaller files
- ✧ Collections of SEDS files are needed for releases

✦ SEDS

- ✧ Opportunities to expand on the use of SEDS
 - ◆ State Diagrams
 - ◆ Device Interfaces (IO,...)
 - ◆ Dynamic Importance Maps
 - ◆ ...

✦ Standardized International Autonomy and Timeline Building Blocks

✦ Opportunity to influence the next CCSDS SEDS Blue Book update

✦ SEDS was intended to replace XTCE

- ✧ SEDS represents more than XTCE and is more object-orientated. Should promote a gradual shift towards SEDS if possible.

SEDS Usage by cFS Community

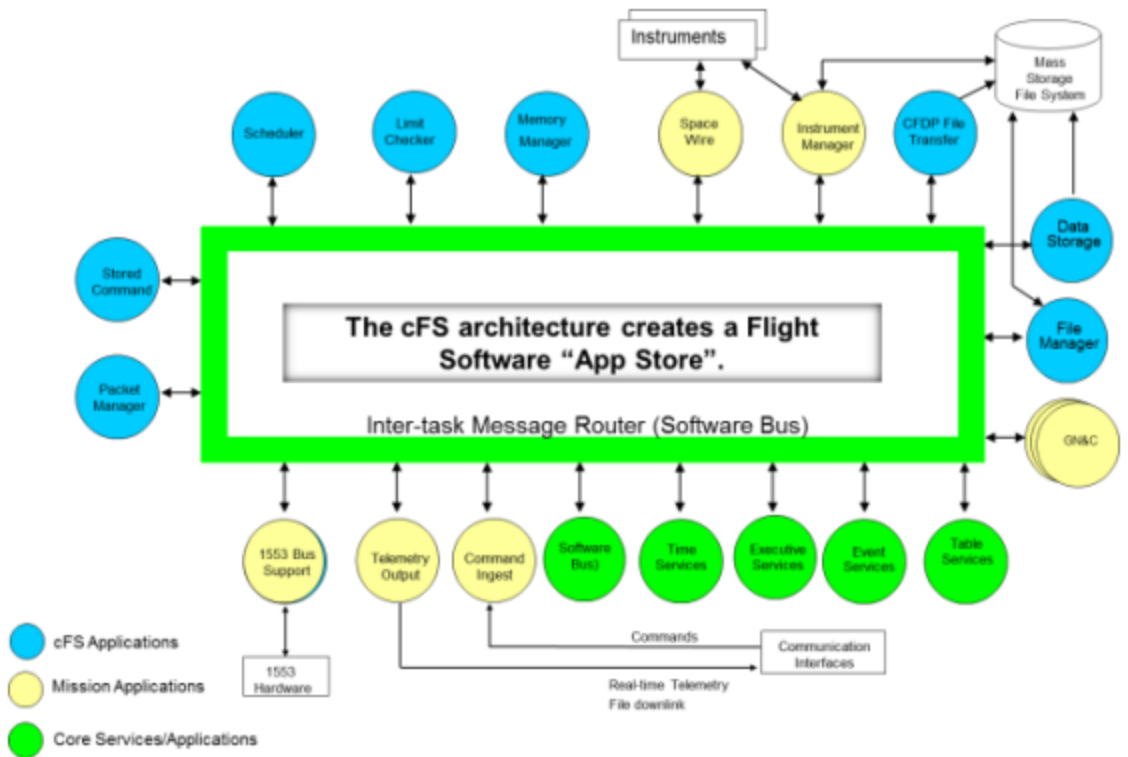

Goddard's Core Flight Software Chosen for NASA's Lunar Gateway

NASA is improving a flight software system to help create and certify essential software for the lunar Gateway.

Application Areas



Landers and Rovers

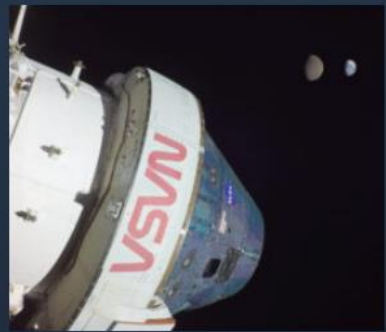

Crewed Spaceflight



Satellite Platforms and Payloads



Launch and Mission Systems

A Snippet of cFS Usage

```
55     <ContainerDataType name="HkTlm_Payload" shortDescription="HK housekeeping">
56     <EntryList>
57         <Entry name="CmdCount" type="BASE_TYPES/uint8" shortDescription="Count of valid commands received" />
58         <Entry name="CmdErrCount" type="BASE_TYPES/uint8" shortDescription="Count of invalid commands received" />
59
60         <Entry name="CurrentAppMonState" type="BASE_TYPES/uint8" />
61         <Entry name="CurrentEventMonState" type="BASE_TYPES/uint8" />
62         <Entry name="CurrentAlivenessState" type="BASE_TYPES/uint8" />
63         <Entry name="CurrentCPUHogState" type="BASE_TYPES/uint8" />
64         <Entry name="StatusFlags" type="BASE_TYPES/uint8" />
65         <Entry name="SpareBytes" type="BASE_TYPES/uint8" />
66         <Entry name="ResetsPerformed" type="BASE_TYPES/uint16" />
67         <Entry name="MaxResets" type="BASE_TYPES/uint16" />
68         <Entry name="EventsMonitoredCount" type="BASE_TYPES/uint32" />
69         <Entry name="InvalidEventMonCount" type="BASE_TYPES/uint32" />
70
71         <Entry name="AppMonEnables" type="AppMonEnables" />
72
73         <Entry name="MsgActExec" type="BASE_TYPES/uint32" />
74         <Entry name="UtilCpuAvg" type="BASE_TYPES/uint32" />
75         <Entry name="UtilCpuPeak" type="BASE_TYPES/uint32" />
76
77         <Entry name="ExeCounts" type="ExeCounts" />
78     </EntryList>
79 </ContainerDataType>
```

Subnet WG

- **Suspended** until support from missions and second agency is obtained
- There is significant value for subnet standards for device discovery, enumeration, and configuration for crewed spacecraft and surface systems, but we need mission support

SOIS-WIR WG

- **Suspended** until support from missions and second agency is obtained
- Recent Publication
 - `CCSDS 883.0-B-2, Spacecraft Onboard Interface Services—High Data Rate Wireless Proximity Network Communications (Blue Book, Issue 2)

CCSDS Plenary Spring 2026 Area Report

Space Internetworking Services (SIS) Area

Tomaso de Cola (ESA), Vinnie Ristovski (NASA/MSFC)
(presented by Simon Singh, NASA)



Space Internetworking Services (SIS) Main Items and Preview

- Highlights since last meeting:
 - New features for BPv7 subject of several orange books targeting publication within 2026
 - CFDP Unitdata Transfer Layer Magenta Book approved for publication
 - DTN Compressed Bundle Status Reporting and Custodial Transfer: pending CESG RIDs to be resolved → Publication targeted before August'26
 - **Custody transfer was tested onboard the Cislunar Autonomous Positioning System Technology Operations and Navigation Experiment (CAPSTONE) spacecraft during multiple uplink and downlink passes at lunar distances.**
- Issues to be resolved
 - Future of DTN orange books towards blue book track or IETF RFCs (with following profiling in CCSDS for BPv7)



SIS Main focus areas for the week (1)

CFDP

- Not meeting
- CFDP UT Magenta book approved for publication
- CFDP P5.1 (future B.6) soon under CESG poll for agency review approval

MIVA

- Not meeting because of low availability of key people
- Technical discussions to be resumed in ad-hoc remote meetings in June (date still TBD)

SIS Main focus areas for the week (2)

DTN

- BPv7 Blue Book and related:
 - Interoperability testing
 - Progress and planning for the existing orange/yellow books:
 - Multicast Naming Scheme
 - BIBE
 - Network Management (jointly with SEA, CSS and SOIS):
 - DTN ConOps
 - LunaNet ConOps
 - DTN for Optical Comm ground networks
 - DTN Managed Information Orange Book
 - DTN NM, AMP, AMM Orange Book
 - General vision on network management for CCSDS
 - LunaNet
 - DTN requirements
 - BPSec (jointly with SEA-SEC):
 - BPSec Blue Book Interoperability Testing
 - BPSec COSE Security Context & Discussion
 - PQC in IETF & Discussion
 - Key Management
 - Potential future Green/Magenta Books
 - BPSec library
- Joint Meetings:
- Security WG → BP-related security topics (see above)
 - SEA, CSS, SOIS → General network management vision for CCSDS
 - SEA-TIME

✦ BPNode, a cFS based DTN Node was used for inflight testing of Custody Transfer at Lunar Distances

- ✧ File transfer using Custody Transfer
 - ◆ CCSDS 734.6-O-1
- ✧ Multiple passes
- ✧ Multiple nodes
- ✧ Validate the use of the Management Information Base (MIB) to determine the
 - ◆ status of the flight node,
 - ◆ track bundle status, and
 - ◆ identify bundle drops due to link issues

✦ CAPSTONE

- ✧ For its extended mission, it has been retrofitted to serve as a testbed for various technology demonstrations. Its payload computer was completely rewritten
- ✧ Cislunar Autonomous Positioning System Technology Operations and Navigation Experiment



In Flight Testing of Custody Transfer at Lunar Distances

✦ “Tests without the CCSDS Custody Transfer feature suffered from the occasional bundle drop, even when limiting the bundle transmission rates. Enabling CCSDS Custody Transfer solved this problem immediately, as this forced nodes to hold onto bundle copies in storage and retransmit them until a transfer acknowledgement was received from the downstream node. This easily proves the need for this feature in any DTN system.”

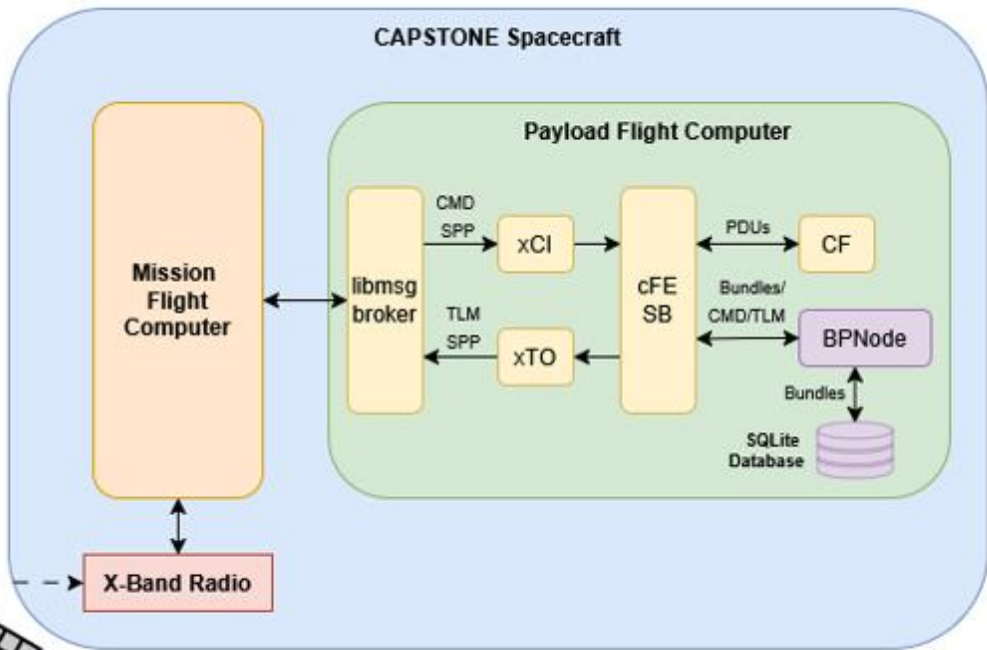
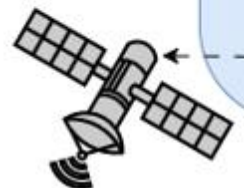
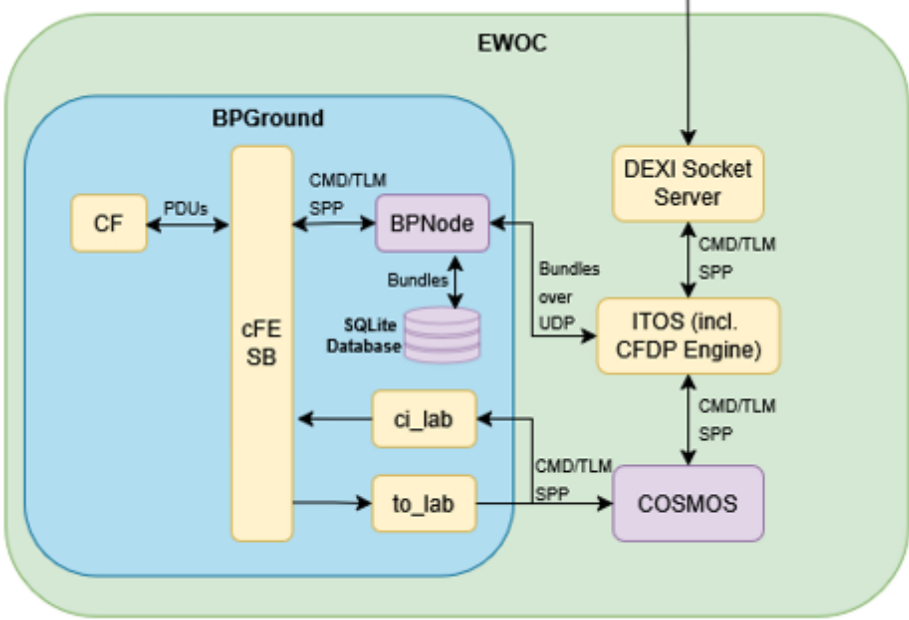
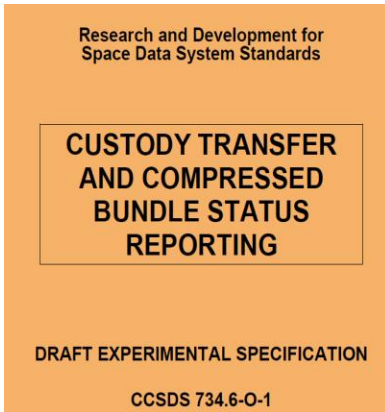

- ✦ After initial ground testing, the software, test tools, and scripts were released to the public in these NASA GitHub repositories:
 - ✧ – <https://github.com/nasa/bplib>
 - ✧ – <https://github.com/nasa/bp>
 - ✧ – <https://github.com/nasa/dtn-tools>

- ✦ Implementation Name BPNode
- ✦ Implementation Version Build 7.0.5
- ✦ Special Configuration Flight Software DTN Node hosted on cFS
- ✦ Supplier NASA-GSFC
- ✦ Contact Point for Queries gsfc-dtn@nasa.onmicrosoft.com

CCSDS Plenary Spring 2026 Area Report

Space Link Services (SLS) Area

Clemens Heese (ESA), Jean-Luc Issler (CNES)



Overview SLS (Space Link Services) Area

In order of the CCSDS layer stack:

RFM – RF & Modulation

C&S – Coding and Synchronization

SLP – Space Link Protocols

DC – Data compression

DLS – Data Link Security

Combining two layers in the optical domain:

OPT – Optical Communication (Opt. & Modulation + C&S)

Space Link Services Area (SLS)
Director: Dr. Clemens Heese
Deputy: Jean-Luc Issler

RF Modulation Working Group (SLS-RFM)
Chair: Dennis Lee
Deputy: Gunther Sessler

Space Link Coding and Synchronization Working Group (SLS-C&S)
Chair: Andrea Modenini
Deputy: Kenneth Andrews

Data Compression Working Group (SLS-DC)
Chair: Aaron Kiely
Deputy: Lucana Santos

Space Link Protocols Working Group (SLS-SLP)
Chair: Greg Kazz
Deputy: Matthew Cosby

Space Data Link Layer Security Working Group (SLS-SEA-DLS)
Chair: Bruno Saba
Deputy: Howard Weiss

Optical Communications Working Group (SLS-OPT)
Chair: Jon Hamkins
Deputy: Clemens Heese

- **Highlights since Fall 2025 meetings:**

- SLS-OPT published 141.0-B-2 & 142.0-B-2 - 'Non-coherent optical communication'
- SLS-SLP published 732.0-B-5 and 235.1-R-1, 211.0, 211.1, 211.2 going to Agency Review - 'USLP'
- 'GSC' + 'Prox-1 stack'
- SLS-C&S published 131.0-B-6 - 'TM sync & channel coding'
- Lunanet SIG was formed and had kickoff meeting on February.
Reviewed and provided comments on Lunanet AD1 Vol A document.

- **Issues to be resolved during Spring 2026 meetings:**

- SLS-C&S WG chair vacant - Ken Andrews is acting.
- Lunanet SIG:
 - Discuss needed work and planned dates from the individual CCSDS WG's to compare with Lunanet need dates. This is to inform and help CESG/CMC prioritize work, given limited resources on all agencies.

Overview current “active” standards

WGs	Number	Color	Document Title
SLS-RFM	211.1-B-4	blue	Proximity-1 Space Link Protocol—Physical Layer
SLS-RFM	401.0-B-32	blue	Radio Frequency and Modulation Systems—Part 1: Earth Stations and Spacecraft
SLS-RFM	414.1-B-3	blue	Pseudo-Noise (PN) Ranging Systems
SLS-RFM	415.1-B-1	blue	Data Transmission and PN Ranging for 2 GHz CDMA Link via Data Relay Satellite
SLS-C&S	131.0-B-5	blue	TM Synchronization and Channel Coding
SLS-C&S	131.3-B-2	blue	CCSDS Space Link Protocols over ETSI DVB-S2 Standard
SLS-C&S	211.2-B-3	blue	Proximity-1 Space Link Protocol—Coding and Synchronization Sublayer
SLS-C&S	231.0-B-4	blue	TC Synchronization and Channel Coding
SLS-SLP	132.0-B-3	blue	TM Space Data Link Protocol
SLS-SLP	211.0-B-6	blue	Proximity-1 Space Link Protocol—Data Link Layer
SLS-SLP	232.0-B-4	blue	TC Space Data Link Protocol
SLS-SLP	235.1-B-0	blue	Generic Session Control
SLS-SLP	732.0-B-5	blue	AOS Space Data Link Protocol
SLS-SLP	732.1-B-3	blue	Unified Space Data Link Protocol
SLS-SLP	130.0-G-4	green	Overview of Space Communications Protocols
SLS-SLP	700.1-G-1	green	Overview of the Unified Space Data Link Protocol
SLS-DC	123.0-B-2	blue	Low-Complexity Lossless and Near-Lossless Multispectral and Hyperspectral Image Compression
SLS-DC	124.0-B-1	blue	Robust Compression of Fixed-Length Housekeeping Data
SLS-DC	120.2-G-2	green	Low-Complexity Lossless and Near-Lossless Multispectral and Hyperspectral Image Compression
SLS-OPT	141.0-B-2	blue	Non-Coherent Optical Communications Physical Layer
SLS-OPT	142.0-B-2	blue	Non-Coherent Optical Communications Coding and Synchronization
SLS-OPT	141.1-M-1	magenta	Atmospheric Characterization and Forecasting for Optical Link Operations
SLS-SEA-DLS	355.0-B-2	blue	Space Data Link Security Protocol
SLS-SEA-DLS	355.1-B-1	blue	Space Data Link Security Protocol—Extended Procedures

Overview current “passive” standards

WGs	Number	Color	Document Title	5yr rev?
SLS-C&S	131.2-B-2	blue	Flexible Advanced Coding and Modulation Scheme for High Rate Telemetry Applications	up-to-date
SLS-C&S	431.1-B-1	blue	Variable Coded Modulation Protocol	up-to-date
SLS-C&S	130.1-G-3	green	TM Synchronization and Channel Coding—Summary of Concept and Rationale	
SLS-C&S	130.11-G-2	green	SCCC-Summary of Definition and Performance	
SLS-C&S	130.12-G-2	green	CCSDS Protocols over DVB-S2-Summary of Definition, Implementation, and Performance	
SLS-C&S	210.0-G-2	green	Proximity-1 Space Link Protocol—Rationale, Architecture, and Scenarios	
SLS-C&S	230.1-G-3	green	TC Synchronization and Channel Coding—Summary of Concept and Rationale	
SLS-C&S	131.21-O-1	orange	Serially Concatenated Convolutional Codes—Extension (SCCC-X)	
SLS-C&S	131.31-O-1	orange	CCSDS Space Link Protocols over ETSI DVB-S2X Standard	
SLS-DC	121.0-B-3	blue	Lossless Data Compression	needed
SLS-DC	122.0-B-2	blue	Image Data Compression	needed
SLS-DC	122.1-B-1	blue	Spectral Preprocessing Transform for Multispectral and Hyperspectral Image Compression	needed
SLS-DC	120.0-G-4	green	Lossless Data Compression	
SLS-DC	120.1-G-3	green	Image Data Compression	
SLS-DC	120.3-G-1	green	Spectral Pre-Processing Transform for Multispectral & Hyperspectral Image Compression	
SLS-OPT	140.1-G-2	green	Real-Time Weather and Atmospheric Characterization Data	
SLS-OPT	141.10-O-1	orange	Optical High Data Rate (HDR) Communication—1550 NM	
SLS-OPT	141.11-O-1	orange	Optical High Data Rate (HDR) Communication—1064 NM	
SLS-OPT	142.10-O-1	orange	Reed-Solomon Product Code for Optical Communication	
SLS-RFM	413.0-G-3	green	Bandwidth-Efficient Modulations—Summary of Definition, Implementation, and Performance	
SLS-RFM	413.1-G-2	green	Simultaneous Transmission of GMSK Telemetry and PN Ranging	
SLS-RFM	414.0-G-2	green	Pseudo-Noise (PN) Ranging Systems	
SLS-RFM	415.0-G-1	green	Data Transmission and PN Ranging for 2 GHz CDMA Link via Data Relay Satellite	
SLS-SLP	133.0-B-2	blue	Space Packet Protocol	needed
SLS-SLP	133.1-B-3	blue	Encapsulation Packet Protocol	needed
SLS-SLP	232.1-B-2	blue	Communications Operation Procedure-1	needed
SLS-SLP	130.2-G-3	green	Space Data Link Protocols—Summary of Concept and Rationale	
SLS-SLP	130.3-G-1	green	Space Packet Protocols	

Action for spring meetings on the red marked books to either:

- a) conduct 5-year revision of blue books and hand the updated word document to the SLS-AD for endorsement,
- b) or reach WG consensus so we can issue a resolution to silverise books and ask for CESG/CMC approval.

Planned work this week per WG



- ❑ 211.1-B-4 Proximity-1 Space Link Protocol - Physical Layer
 - Pink book covering S-band and lunar Prox-1 physical layer extensions currently in CESG polling for approval **to be released for agency review** (poll closed May 14, 2026)
 - **Future extension** of 211.1-B for K-band Prox-1 physical layer planned

- ❑ 401.0-B-32 Radio Frequency and Modulation Systems—Part 1: Earth Stations and Spacecraft
 - Pink sheets for new or modified 401.0-B Recommendations 2.2.9, 2.2.10, and 2.4.7 approved by WG and **ready for technical editor**

- ❑ 414.1-B-3 Pseudo-Noise (PN) Ranging Systems
 - **Discussions** on proximity PN ranging codes to be added to 414.1 blue book (work in progress)

- ❑ 415.1-B-1 Data Transmission and PN Ranging for 2 GHz CDMA Link via Data Relay Satellite
 - 415.1-B pink sheets with additions for CDMA non-regenerative ranging and lunar approved by WG and **ready for technical editor**

- ❑ 131.0-B-6 - TM Synchronization and Channel Coding
 - New edition published on May 6, 2026.
 - **Presentation** anticipated on the use of dual convolutional encoders with RS+CC coding for a future edition.

- ❑ 131.2-B-2 - Flexible Advanced Coding and Modulation Scheme for High Rate Telemetry Applications
 - Nothing planned. Technical corrigendum on “Pseudo randomizer length” awaits **technical editor assignment for CESG poll creation**.

- ❑ 131.3-B-2 - CCSDS Space Link Protocols over ETSI DVB-S2 Standard
 - Nothing planned

- ❑ 211.2-B-3 - Proximity-1 Space Link Protocol—Coding and Synchronization Sublayer
 - Technical corrigendum to clarify LDPC byte synchronization **awaits work by editors**
 - WG will address comments that triggered CESG **disapproval**, and will **generate a revision for CESG approval**

- ❑ 231.0-B-4 - TC Synchronization and Channel Coding
 - Technical corrigendum to remove extraneous tail sequence byte completed CESG polling on May 1, 2026.
Follow up publication with technical editor.

- ❑ 431.1-B-1 - Variable Coded Modulation Protocol
 - **Presentations** anticipated on the use of **VCM** and Adaptive Data Rate (**ADR**)

- 132.0-B-3 - TM Space Data Link Protocol
 - No other activity planned
- 133.0-B-2 - Space Packet Protocol
 - No other activity planned
- 133.1-B-3 - Encapsulation Packet Protocol
 - No other activity planned
- 211.0-B-6 - Proximity-1 Space Link Protocol - Data Link Layer
 - **CESG Poll to go to agency review closes May 14, 2026**
- 232.0-B-4 - TC Space Data Link Protocol
 - No other activity planned
- 232.1-B-2 - Communications Operation Procedure-1
 - No other activity planned
- 235.1-B-0 – Space Communications Session Control
 - **CESG Poll to go to agency review closes May 14, 2026**
- 732.0-B-5 - AOS Space Data Link Protocol
 - No other activity planned
- 732.1-B-3 - Unified Space Data Link Protocol
 - **Reach consensus on Clarification of VCA and VCP services**

- ❑ 121.0-B-3 Lossless Data Compression
 - WG agreed to **reconfirm** (Fall 2025 meeting in Hamburg)
- ❑ 122.0-B-2 Image Data Compression
 - WG agreed to **reconfirm** (Fall 2025 meeting in Hamburg)
- ❑ 122.1-B-1 Spectral Preprocessing Transform for Multispectral and Hyperspectral Image Compression
 - WG agreed to **reconfirm** (Fall 2025 meeting in Hamburg)
- ❑ 123.0-B-2 Low-Complexity Lossless and Near-Lossless Multispectral and Hyperspectral Image Compression
 - **Issue-3 revision underway**, with cross-verification nearing completion.
- ❑ 124.0-B-1 Robust Compression of Fixed-Length Housekeeping Data
 - **Proposal for Issue-2 revision** (to add option to package compressed output into a file structure) to be considered at this (Spring 2026) meeting.
 - *Anticipated requirement for AD action*: approval of new project to develop Issue-2 revision.

- ❑ 355.0-B-2 - Space Data Link Security Protocol
 - 3KEM update

- ❑ 355.1-B-1 - Space Data Link Security Protocol - Extended Procedures
 - 5-year revision or silverise book.

141.0-B-2 - Non-Coherent Optical Communications Physical Layer

- B2 just published.
- No other activity planned

142.0-B-2 - Non-Coherent Optical Communications Coding and Synchronization

- B2 just published.
- **Finalize technical corrigendum on IFS markers and PICs proforma.**
- Reach consensus to publish technical corrigendum.
- **Reach consensus to give GFP pink sheets into Agency review**, and on adequacy of Yellow Book test report on GFP
- Path forward on optical ranging standard (spec is approved but no 2nd prototype yet)

14X.0-B-1 - Coherent Optical Communications

- Pilot / CSM / framing / mask analysis, **discussion** on code performance/carrier tracking, proposal discussion for inband signalling, discussion synchronization approach.

- ❑ Report on Lunanet standardisation needs. Agenda for the Spring meeting so far includes the following:
 - Discuss WG comments on LunaNet needs list
 - Discuss the comments from AD1 Vol. A feedback assigned as internal SIG comments.
 - Discuss plan/task list for LunaNet SIG outputs
 - Discuss PNT standards within CCSDS

Highlight missions enabled by standards: 2025 / 2026



7/8 LDPC AR4JA

Tracking interop.
 Audio+Video

90% data optical
 Fully interop. ground segm.
 First interop. demo

- 401.0-B-32 RF and mod. Systems Part 1
- 131.0-B-5 TM Synchronization and Channel Coding
- 231.0-B-4 TC Synchronization and Channel Coding
- 132.0-B-3 TM Space Data Link Protocol
- 232.0-B-4 TC Space Data Link Protocol
- 732.0-B-5 AOS Space Data Link Protocol
- 732.1-B-3 Unified Space Data Link Protocol
- 141.0-B-2 Non-Coherent Optical Comm. Physical Layer
- 142.0-B-2 Non-Coherent Optical Comm. Coding and Synchronization



TECHNICAL EDITOR ANNUAL REPORT

Mayagüez, May 2026 Spring Meeting

CCSDS Technical Co- Editors:

Natalya Stepanova
NASA GSFC
natalya.stepanova@nasa.gov

Lee Stablein
NASA GSFC
lee.m.stablein@nasa.gov

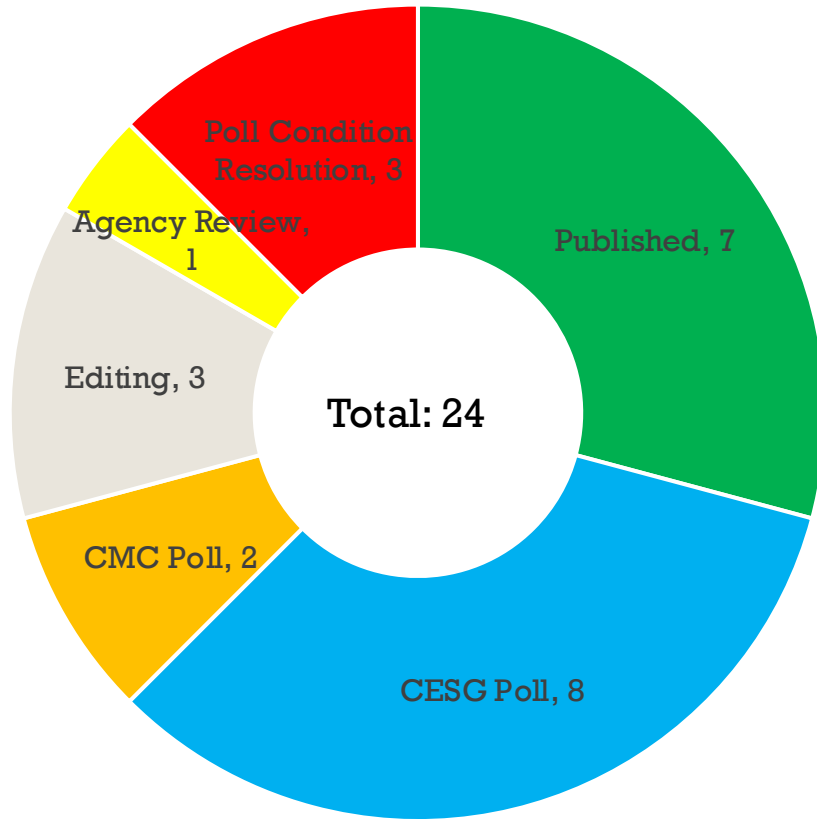

JUNE 1, 2025

-

MAY 25, 2026

Published Books

(7):

- 131.0-B-6: TM Synchronization and Channel Coding
- 141.0-B-2: Optical Communications Physical Layer
- 142.0-B-2: Non-Coherent Optical Communications Coding and Synchronization
- 502.0-B-3: Orbit Data Messages
- 732.0-B-5: AOS Space Data Link Protocol
- 734.1-B-1: Licklider Transmission Protocol
- 734.20-O-1: CCSDS Bundle Protocol Version 7

Agency Review

(1):

- 902.11-B-1: Cross Support Service Management–Best Practices

Books in Polling & Conditions

CESG Polling

- **131.2-B-2:** Flexible Advanced Coding & Modulation Scheme for High Rate Telemetry Applications Corrigendum
- **211.0-B-7:** Proximity-1– Data Link Layer
- **211.1-B-5:** Proximity-1– Physical Layer
- **211.2-P-3.2:** Proximity-1 Coding & Sync Sublayer
- **231.0-B-4:** TC Sync & Coding Corrigendum
- **235.1-R-0:** Space Communications Session Control
- **529.1-B-1:** Mission Operations—Mission Planning
- **722.1-M-1:** CFDP Unitdata Transfer Layers

Resolution

Polling Conditions Resolution

- **734.6-O-1:** Custody Transfer & Compressed Bundle Status
- **902.4-B-1:** Cross Support Service Management—Service Package Data Formats
- **902.9-B-1:** Service Management Utilization Request Format
- **902.12-M-2:** Cross Support Service Management—Common Data Entities

CMC Polling

- **520.1-M-2:** Mission Operations Reference Model
- **734.6-O-1:** Custody Transfer & Compressed Bundle Status

Active Editing:

506.1-B-2: Delta-DOR
Raw Data Exchange
Format

211.2-B-3: Proximity-1
Space Link Protocol—
Coding and
Synchronization Sublayer
Technical Corrigendum

[need number]: Secure
Software Development

Queue

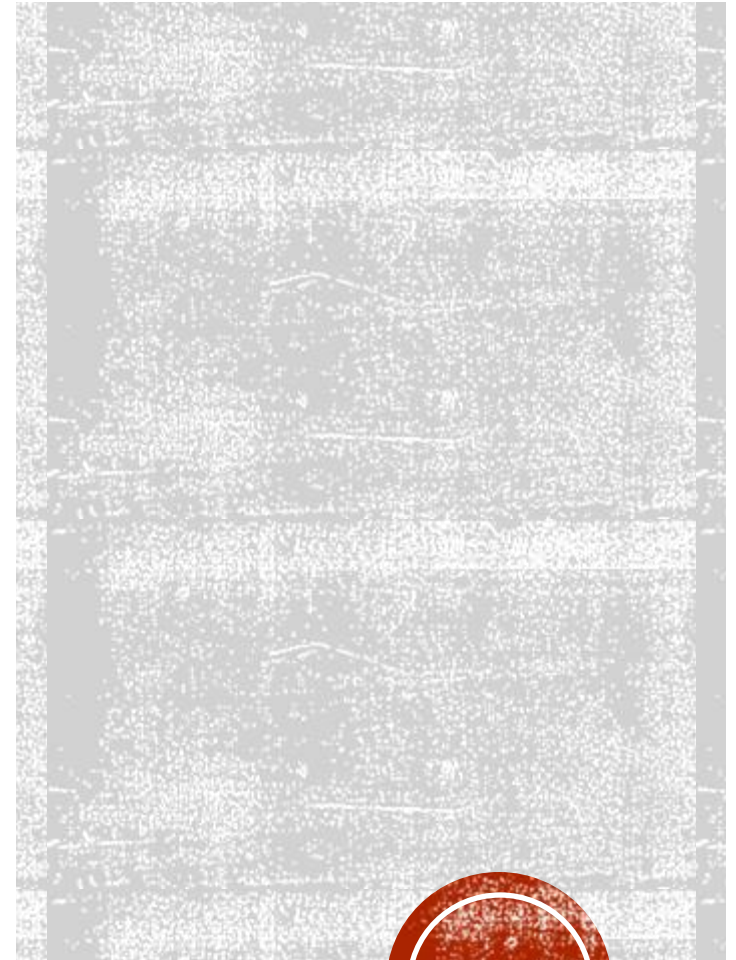
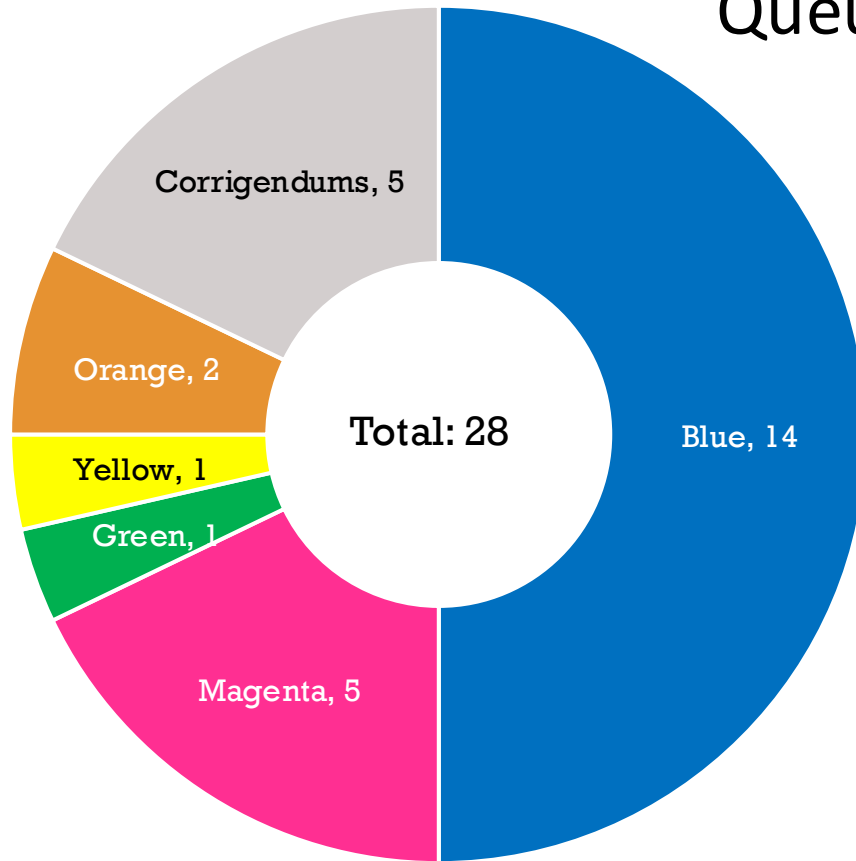

Recycle bin

Welcome to the CCSDS Management Framework.
This online system integrates key CCSDS web-based management activities into one centralized location for easy access. If you have any questions or concerns, please contact CCSDS IT Tech Support at techsupport@mailman.ccsds.org.

▼ 🗳️ Polling

▼ 📜 Charters

▼ 🛠️ Projects

▼ 🤝 ICPA

▼ 👤 Resources

4 ▲ 📝 Tech Editor Queue

Shows the current status of the books being worked on by the CCSDS Tech Editors.

📁 All Open Books

📁 All Completed Books

📄 Submit a New Book Directions