

Recommendation for Space Data System Practices

**FUNCTIONAL
RESOURCE MODEL**

RECOMMENDED PRACTICE

CCSDS 901.3-M-1

MAGENTA BOOK

February 2024

Recommendation for Space Data System Practices

**FUNCTIONAL
RESOURCE MODEL**

RECOMMENDED PRACTICE

CCSDS 901.3-M-1

MAGENTA BOOK

February 2024

AUTHORITY

Issue:	Recommended Practice, Issue 1
Date:	February 2024
Location:	Washington, DC, USA

This document has been approved for publication by the Management Council of the Consultative Committee for Space Data Systems (CCSDS) and represents the consensus technical agreement of the participating CCSDS Member Agencies. The procedure for review and authorization of CCSDS documents is detailed in *Organization and Processes for the Consultative Committee for Space Data Systems* (CCSDS A02.1-Y-4), and the record of Agency participation in the authorization of this document can be obtained from the CCSDS Secretariat at the email address below.

This document is published and maintained by:

CCSDS Secretariat
National Aeronautics and Space Administration
Washington, DC, USA
Email: secretariat@mailman.ccsds.org

STATEMENT OF INTENT

The Consultative Committee for Space Data Systems (CCSDS) is an organization officially established by the management of its members. The Committee meets periodically to address data systems problems that are common to all participants, and to formulate sound technical solutions to these problems. Inasmuch as participation in the CCSDS is completely voluntary, the results of Committee actions are termed **Recommendations** and are not in themselves considered binding on any Agency.

CCSDS Recommendations take two forms: **Recommended Standards** that are prescriptive and are the formal vehicles by which CCSDS Agencies create the standards that specify how elements of their space mission support infrastructure shall operate and interoperate with others; and **Recommended Practices** that are more descriptive in nature and are intended to provide general guidance about how to approach a particular problem associated with space mission support. This **Recommended Practice** is issued by, and represents the consensus of, the CCSDS members. Endorsement of this **Recommended Practice** is entirely voluntary and does not imply a commitment by any Agency or organization to implement its recommendations in a prescriptive sense.

No later than five years from its date of issuance, this **Recommended Practice** will be reviewed by the CCSDS to determine whether it should: (1) remain in effect without change; (2) be changed to reflect the impact of new technologies, new requirements, or new directions; or (3) be retired or canceled.

In those instances when a new version of a **Recommended Practice** is issued, existing CCSDS-related member Practices and implementations are not negated or deemed to be non-CCSDS compatible. It is the responsibility of each member to determine when such Practices or implementations are to be modified. Each member is, however, strongly encouraged to direct planning for its new Practices and implementations towards the later version of the Recommended Practice.

FOREWORD

Through the process of normal evolution, it is expected that expansion, deletion, or modification of this document may occur. This Recommended Practice is therefore subject to CCSDS document management and change control procedures, which are defined in the *Organization and Processes for the Consultative Committee for Space Data Systems* (CCSDS A02.1-Y-4). Current versions of CCSDS documents are maintained at the CCSDS Web site:

<http://www.ccsds.org/>

Questions relating to the contents or status of this document should be sent to the CCSDS Secretariat at the email address indicated on page i.

At time of publication, the active Member and Observer Agencies of the CCSDS were:

Member Agencies

- Agenzia Spaziale Italiana (ASI)/Italy.
- Canadian Space Agency (CSA)/Canada.
- Centre National d’Etudes Spatiales (CNES)/France.
- China National Space Administration (CNSA)/People’s Republic of China.
- Deutsches Zentrum für Luft- und Raumfahrt (DLR)/Germany.
- European Space Agency (ESA)/Europe.
- Federal Space Agency (FSA)/Russian Federation.
- Instituto Nacional de Pesquisas Espaciais (INPE)/Brazil.
- Japan Aerospace Exploration Agency (JAXA)/Japan.
- National Aeronautics and Space Administration (NASA)/USA.
- UK Space Agency/United Kingdom.

Observer Agencies

- Austrian Space Agency (ASA)/Austria.
- Belgian Science Policy Office (BELSPO)/Belgium.
- Central Research Institute of Machine Building (TsNIIMash)/Russian Federation.
- China Satellite Launch and Tracking Control General, Beijing Institute of Tracking and Telecommunications Technology (CLTC/BITTT)/China.
- Chinese Academy of Sciences (CAS)/China.
- China Academy of Space Technology (CAST)/China.
- Commonwealth Scientific and Industrial Research Organization (CSIRO)/Australia.
- Danish National Space Center (DNSC)/Denmark.
- Departamento de Ciência e Tecnologia Aeroespacial (DCTA)/Brazil.
- Electronics and Telecommunications Research Institute (ETRI)/Korea.
- Egyptian Space Agency (EgSA)/Egypt.
- European Organization for the Exploitation of Meteorological Satellites (EUMETSAT)/Europe.
- European Telecommunications Satellite Organization (EUTELSAT)/Europe.
- Geo-Informatics and Space Technology Development Agency (GISTDA)/Thailand.
- Hellenic National Space Committee (HNSC)/Greece.
- Hellenic Space Agency (HSA)/Greece.
- Indian Space Research Organization (ISRO)/India.
- Institute of Space Research (IKI)/Russian Federation.
- Korea Aerospace Research Institute (KARI)/Korea.
- Ministry of Communications (MOC)/Israel.
- Mohammed Bin Rashid Space Centre (MBRSC)/United Arab Emirates.
- National Institute of Information and Communications Technology (NICT)/Japan.
- National Oceanic and Atmospheric Administration (NOAA)/USA.
- National Space Agency of the Republic of Kazakhstan (NSARK)/Kazakhstan.
- National Space Organization (NSPO)/Chinese Taipei.
- Naval Center for Space Technology (NCST)/USA.
- Netherlands Space Office (NSO)/The Netherlands.
- Research Institute for Particle & Nuclear Physics (KFKI)/Hungary.
- Scientific and Technological Research Council of Turkey (TUBITAK)/Turkey.
- South African National Space Agency (SANSA)/Republic of South Africa.
- Space and Upper Atmosphere Research Commission (SUPARCO)/Pakistan.
- Swedish Space Corporation (SSC)/Sweden.
- Swiss Space Office (SSO)/Switzerland.
- United States Geological Survey (USGS)/USA.

DOCUMENT CONTROL

Document	Title	Date	Status
CCSDS 901.3-M-1	Functional Resource Model, Recommended Practice, Issue 1	February 2024	Original issue
EC 1	Editorial Change 1	October 2024	Corrects – table of contents formatting; – spelling and element arrangement in various figures.

CONTENTS

<u>Section</u>	<u>Page</u>
1 INTRODUCTION	1-1
1.1 PURPOSE OF THIS RECOMMENDED PRACTICE	1-1
1.2 BACKGROUND	1-1
1.3 SCOPE	1-2
1.4 APPLICABILITY	1-3
1.5 RATIONALE	1-4
1.6 DOCUMENT ORGANIZATION	1-4
1.7 DEFINITIONS	1-5
1.8 NOMENCLATURE	1-8
1.9 COMPONENTS OF FUNCTIONAL RESOURCE DEFINITIONS	1-8
1.10 REFERENCES	1-10
2 FUNCTIONAL RESOURCE MODEL OVERVIEW	2-1
2.1 GENERAL	2-1
2.2 FUNCTIONAL RESOURCES	2-1
3 FUNCTIONAL RESOURCE MODEL CONCEPTS	3-1
3.1 FUNCTIONAL RESOURCE STRATA	3-1
3.2 FUNCTIONAL RESOURCE SETS	3-6
3.3 SERVICE CONFIGURATION CATEGORIES	3-8
3.4 RELATIONSHIPS AMONG AND WITHIN FUNCTIONAL RESOURCE SETS	3-13
3.5 SANA FUNCTIONAL RESOURCES REGISTRY	3-16
4 APERTURE FUNCTIONAL RESOURCE STRATUM	4-1
4.1 GENERAL	4-1
4.2 RF APERTURE FUNCTIONAL RESOURCE SET OF THE APERTURE FUNCTIONAL RESOURCE STRATUM	4-1
5 PHYSICAL CHANNEL FUNCTIONAL RESOURCE STRATUM	5-1
5.1 OVERVIEW	5-1
5.2 CCSDS 401 PHYSICAL CHANNEL TRANSMISSION FUNCTIONAL RESOURCE SET OF THE PHYSICAL CHANNEL ABSTRACT STRATUM	5-1
5.3 CCSDS 401 PHYSICAL CHANNEL RECEPTION FUNCTIONAL RESOURCE SET OF THE RETURN PHYSICAL CHANNEL RECEPTION FUNCTIONAL RESOURCE STRATUM	5-4

CONTENTS (continued)

<u>Section</u>	<u>Page</u>
5.4 DELTA-DOR RAW DATA COLLECTION FUNCTIONAL RESOURCE SET OF THE PHYSICAL CHANNEL FUNCTIONAL RESOURCE STRATUM.....	5-8
5.5 OPEN LOOP DATA COLLECTION FUNCTIONAL RESOURCE SET OF THE PHYSICAL CHANNEL FUNCTIONAL RESOURCE STRATUM.....	5-9
6 SYNCHRONIZATION AND CHANNEL CODING FUNCTIONAL RESOURCE STRATUM.....	6-1
6.1 OVERVIEW	6-1
6.2 TC SYNCHRONIZATION AND CHANNEL CODING FUNCTIONAL RESOURCE SET OF THE SYNCHRONIZATION AND CHANNEL CODING FR STRATUM.....	6-1
6.3 TM SYNCHRONIZATION AND CHANNEL CODING FUNCTIONAL RESOURCE SET OF THE SYNCHRONIZATION AND CHANNEL CODING FR STRATUM.....	6-7
6.4 TM SYNCHRONIZATION AND CHANNEL CODING FUNCTIONAL RESOURCE SET OF THE SYNCHRONIZATION AND CHANNEL CODING FUNCTIONAL RESOURCE STRATUM	6-11
7 SPACE LINK PROTOCOL FUNCTIONAL RESOURCE STRATUM.....	7-1
7.1 OVERVIEW	7-1
7.2 TC SPACE LINK PROTOCOL TRANSMISSION FUNCTIONAL RESOURCE SET OF THE SPACE LINK PROTOCOL FUNCTIONAL RESOURCE STRATUM	7-1
7.3 AOS SPACE LINK PROTOCOL TRANSMISSION FUNCTIONAL RESOURCE SET OF THE SPACE LINK PROTOCOL TRANSMISSION FUNCTIONAL RESOURCE STRATUM	7-8
7.4 VARIABLE LENGTH FRAME UNIFIED SPACE DATA LINK PROTOCOL TRANSMISSION FUNCTIONAL RESOURCE SET OF THE SPACE LINK PROTOCOL FUNCTIONAL RESOURCE STRATUM.....	7-13
7.5 FIXED LENGTH FRAME UNIFIED SPACE DATA LINK PROTOCOL TRANSMISSION FUNCTIONAL RESOURCE SET OF THE SPACE LINK PROTOCOL FUNCTIONAL RESOURCE STRATUM.....	7-21
7.6 TM/AOS SPACE LINK PROTOCOL RECEPTION FUNCTIONAL RESOURCE SET OF THE SPACE LINK PROTOCOL FUNCTIONAL RESOURCE STRATUM	7-27
7.7 FIXED LENGTH FRAME UNIFIED SPACE DATA LINK PROTOCOL RECEPTION FUNCTIONAL RESOURCE SET OF THE SPACE LINK PROTOCOL FUNCTIONAL RESOURCE STRATUM	7-33

CONTENTS (continued)

<u>Section</u>	<u>Page</u>
8 SLS DATA DELIVERY PRODUCTION FUNCTIONAL RESOURCE STRATUM.....	8-1
8.1 OVERVIEW.....	8-1
8.2 FRAME DATA SINK FUNCTIONAL RESOURCE SET OF THE SLS DATA DELIVERY PRODUCTION FUNCTIONAL RESOURCE STRATUM.....	8-1
9 SLS RADIOMETRIC DATA PRODUCTION FUNCTIONAL RESOURCE STRATUM.....	9-1
9.1 OVERVIEW.....	9-1
9.2 REAL-TIME RADIOMETRIC DATA COLLECTION FUNCTIONAL RESOURCE SET OF THE SLS RADIOMETRIC DATA PRODUCTION FUNCTIONAL RESOURCE STRATUM.....	9-1
9.3 NON-VALIDATED RADIOMETRIC DATA FUNCTIONAL RESOURCE SET OF THE SLS RADIOMETRIC DATA PRODUCTION FUNCTIONAL RESOURCE STRATUM.....	9-27
10 OFFLINE DATA STORAGE FUNCTIONAL RESOURCE STRATUM	10-1
10.1 GENERAL	10-1
10.2 OFFLINE FRAME BUFFER FUNCTIONAL RESOURCE SET OF THE OFFLINE DATA DELIVERY PRODUCTION FUNCTIONAL RESOURCE STRATUM	10-2
10.3 TRACKING DATA MESSAGE RECORDING BUFFER FUNCTIONAL RESOURCE SET OF THE OFFLINE DATA STORAGE FUNCTIONAL RESOURCE STRATUM.....	10-3
10.4 NON-VALIDATED RADIOMETRIC DATA STORE FUNCTIONAL RESOURCE SET OF THE OFFLINE DATA STORAGE FUNCTIONAL RESOURCE STRATUM.....	10-5
10.5 VALIDATED RADIOMETRIC DATA STORE FUNCTIONAL RESOURCE SET OF THE OFFLINE DATA STORAGE FUNCTIONAL RESOURCE STRATUM	10-7
10.6 DELTA-DOR RAW DATA STORE FUNCTIONAL RESOURCE SET OF THE OFFLINE DATA STORAGE FUNCTIONAL RESOURCE STRATUM.....	10-8

CONTENTS (continued)

<u>Section</u>	<u>Page</u>
11 DATA TRANSFER SERVICES FUNCTIONAL RESOURCES STRATUM.....	11-1
11.1 GENERAL	11-1
11.2 SLE FORWARD CLTU FUNCTIONAL RESOURCE SET OF THE DATA TRANSFER SERVICES STRATUM	11-1
11.3 FORWARD FRAME CSTS FUNCTIONAL RESOURCE SET OF THE DATA TRANSFER SERVICES SPECTRUM.....	11-2
11.4 SLE RETURN ALL FRAMES FUNCTIONAL RESOURCE SET OF THE DATA TRANSFER SERVICES FUNCTIONAL RESOURCE STRATUM.....	11-4
11.5 SLE RETURN CHANNEL FRAMES FUNCTIONAL RESOURCE SET OF THE DATA TRANSFER SERVICES FUNCTIONAL RESOURCE STRATUM.....	11-5
11.6 SLE RETURN OPERATIONAL CONTROL FIELDS FUNCTIONAL RESOURCE SET OF THE DATA TRANSFER SERVICES FUNCTIONAL RESOURCE STRATUM	11-7
11.7 TRACKING DATA CSTS FUNCTIONAL RESOURCE SET OF THE DATA TRANSFER SERVICES FUNCTIONAL RESOURCE STRATUM.....	11-8
 12 SERVICE MANAGEMENT FUNCTIONS FUNCTIONAL RESOURCE STRATUM.....	 12-1
12.1 GENERAL	12-1
12.2 MONITORED DATA FUNCTIONAL RESOURCE SET OF THE SERVICE MANAGEMENT FUNCTIONS FUNCTIONAL RESOURCE STRATUM.....	12-1
 13 SPACE INTERNETWORKING FUNCTIONAL RESOURCE STRATUM	 13-1
 ANNEX A OBJECT IDENTIFIER OFFSETS FOR THE FUNCTIONAL RESOURCE STRATA AND FUNCTIONAL RESOURCE SETS (NORMATIVE).....	 A-1
ANNEX B ABBREVIATIONS FOR CONSTRUCTION OF FUNCTIONAL RESOURCE AND PARAMETER/EVENT/DIRECTIVE CLASSIFIERS (NORMATIVE).....	B-1
ANNEX C SECURITY, SANA, AND PATENT CONSIDERATIONS (INFORMATIVE).....	C-1
ANNEX D ABBREVIATIONS AND ACRONYMS (INFORMATIVE).....	D-1
ANNEX E IDENTIFIED FUTURE FUNCTIONAL RESOURCE SETS (INFORMATIVE).....	E-1

CONTENTS (continued)

<u>Section</u>	<u>Page</u>
ANNEX F MAINTENANCE OF THE FUNCTIONAL RESOURCE MODEL (INFORMATIVE).....	F-1

Figure

2-1 Notional Interfaces of the Generic Functional Resource Type.....	2-1
3-1 Functional Resource Strata for Earth-Space Link Terminals	3-4
3-2 Functional Resources Sets within the Strata	3-7
3-3 Functional Resource Strata Used in SLS Configurations	3-9
3-4 Functional Resource Strata and FR Sets Used in Retrieval Configurations	3-10
3-5 Functional Resource Set Connectivity	3-12
3-6 Functional Resource Conceptual Model of Interaction	3-25
3-7 Functional Resource Mixed Architecture Example	3-26
4-1 Member Functional Resource of the RF Aperture Functional Resource Set.....	4-1
5-1 Member Functional Resources of the CCSDS 401 Physical Channel Transmission Functional Resource Set	5-1
5-2 Member Functional Resources of the CCSDS 401 Physical Channel Reception Functional Resource Set	5-4
5-3 Member Functional Resource of the Delta-DOR Raw Data Collection Functional Resource Set.....	5-8
5-4 Member Functional Resources of the Open Loop Data Collection Functional Resource Set.....	5-9
6-1 Member Functional Resource of the TC Synchronization and Channel Encoding Functional Resource Set	6-1
6-2 Internal Structure of the TC PLOP, Synchronization, and Channel Encoding Functional Resource Corresponding to CCSDS 231.0-B-3.....	6-3
6-3 Internal Structure of the TC PLOP, Synchronization, and Channel Encoding Functional Resource Corresponding to CCSDS 231.0-B-4.....	6-4
6-4 Member Functional Resource of the TM Synchronization and Channel Encoding Functional Resource Set	6-7
6-5 Internal Structure of the TM Synchronization and Channel Encoding Functional Resource.....	6-9
6-6 Member Functional Resource of the TM Synchronization and Channel Decoding Functional Resource Set	6-11
6-7 Internal Structure of the TM Synchronization and Channel Decoding Functional Resource.....	6-13
7-1 Member Functional Resources of the TC Space Link Protocol Transmission Functional Resource Set	7-1
7-2 Internal Structure of the TC MC Multiplexing Functional Resource	7-4
7-3 Members of the AOS Space Link Protocol Transmission Functional Resource Set....	7-8

CONTENTS (continued)

<u>Figure</u>	<u>Page</u>
7-4 Internal Structure of the AOS MC Multiplexing Functional Resource	7-11
7-5 Member Functional Resources of the VLF Unified Space Link Protocol Transmission Functional Resource Set	7-14
7-6 Internal Structure of the VLF USLP MC Multiplexing Functional Resource	7-16
7-7 Member Functional Resources of the FLF Unified Space Link Protocol Transmission Functional Resource Set	7-21
7-8 Internal Structure of the FLF USLP MC Multiplexing Functional Resource.....	7-24
7-9 Member Functional Resources of the TM/AOS Space Link Protocol Reception Functional Resource Set	7-27
7-10 Internal Structure of the TM/AOS MC Demultiplexing Functional Resource	7-30
7-11 Internal Structure of the TM/AOS VC Demultiplexing FR.....	7-32
7-12 Member Functional Resources of the FLF USLP Reception Functional Resource Set.....	7-34
7-13 Internal Structure of the FLF USLP VC Demultiplexing FR	7-37
8-1 Member Functional Resource of the Frame Data Sink Member Functional Resource Set.....	8-1
9-1 Member Functional Resources of the Real-Time Radiometric Data Collection Functional Resource Set.....	9-1
9-2 Contents of the Carrier Power Atomic Segment.....	9-4
9-3 Contents of the Pc/No Atomic Segment	9-6
9-4 Contents of the Pr/No Atomic Segment.....	9-7
9-5 Contents of the One-Way Doppler (instantaneous) Atomic Segment	9-9
9-6 Contents of the Two-Way Doppler (instantaneous) Atomic Segment.....	9-10
9-7 Contents of the Three-Way Doppler (Instantaneous) Atomic Segment	9-11
9-8 Contents of the One-Way Doppler (Integrated) Atomic Segment.....	9-14
9-9 Contents of the Two-Way Doppler (Integrated) Atomic Segment	9-15
9-10 Contents of the Three-Way Doppler (Integrated) Atomic Segment	9-16
9-11 Contents of the Two-Way Range Atomic Segment	9-18
9-12 Contents of the Three-Way Range Atomic Segment	9-19
9-13 Contents of the Receive Frequency Atomic Segment.....	9-21
9-14 Contents of the Transmit Frequency Atomic Segment	9-22
9-15 Contents of the Transmit Frequency Rate Atomic Segment.....	9-24
9-16 Contents of the Antenna Angles Atomic Segment	9-25
9-17 Member Functional Resource of the Non-Validated Radiometric Data Collection Functional Resource Stratum	9-27
10-1 Member Functional Resource of the Offline Frame Buffer Functional Resource Set.....	10-2
10-2 Internal Composition of the TDM Recording Functional Resource Set.....	10-3
10-3 Member Functional Resource of the Non-validated Radiometric Data Store Functional Resource Set	10-5
10-4 Member Functional Resource of the Validated Radiometric Data Store Functional Resource Set.....	10-7

CONTENTS (continued)

<u>Figure</u>	<u>Page</u>
10-5 Member Functional Resource of the D-DOR Raw Data Store Functional Resource Set.....	10-8
11-1 Member Functional Resource of the SLE Forward CLTU Functional Resource Set.....	11-1
11-2 Member of the FF-CSTS Functional Resource Set.....	11-2
11-3 Member Functional Resource of the Return All Frames Functional Resource Set.....	11-4
11-4 Member Functional Resource of the Return Channel Frames Functional Resource Set.....	11-5
11-5 Member Functional Resource of the Return Operational Control Fields Functional Resource Set.....	11-7
11-6 Member Functional Resource of the Tracking Data CSTS Functional Resource Set.....	11-8
12-1 Member Functional Resource of the Monitored Data Functional Resource Set	12-1

Table

6-1 Resource Status as a Function of Space Link Availability and Bit Lock	6-6
7-1 PC Managed Parameters of the MC Multiplexing and All Frames Generation Functions of TC SDLP That Are Not in the Configuration Parameters of the TC MC Multiplexing FR.....	7-3
7-2 MC Managed Parameters of the VC Multiplexing Function of TC SDLP That Are Not in the Configuration Parameters of the TC VC Multiplexing FR.....	7-7
7-3 PC Managed Parameters of AOS SDLP That Are Not in the Configuration Parameters of the AOS MC Multiplexing FR.....	7-10
7-4 MC Managed Parameters of the VC Multiplexing Function of AOS SDLP That Are Not in the Configuration Parameters of the AOS VC Multiplexing FR.....	7-12
7-5 PC Managed Parameters of USLP That Are Not in the Configuration Parameters of the VLF USLP MC Multiplexing FR	7-15
7-6 MC Managed Parameters of the VC Multiplexing Function of USLP That Are Not in the Configuration Parameters of the VLF USLP VC Multiplexing FR....	7-19
7-7 PC Managed Parameters of USLP That Are Not in the Configuration Parameters of the FLF USLP MC Multiplexing FR	7-23
7-8 MC Managed Parameters of USLP That Are Not in the Configuration Parameters of the FLF USLP VC Multiplexing FR.....	7-26
7-9 PC Managed Parameters of the TM and AOS SDLP Recommended Standards That Are Not in the Configuration Parameters of the TM/AOS MC Demultiplexing FR.....	7-29
7-10 MC Managed Parameters of the TM and AOS SDLPs That Are Not in the Configuration Parameters of the TM/AOS VC Demultiplexing FR.....	7-32

CONTENTS (continued)

<u>Table</u>	<u>Page</u>
7-11 PC Managed Parameters of USLP That Are Not in the Configuration Parameters of the FLF USLP MC Demultiplexing FR.....	7-35
7-12 PC Managed Parameters of USLP That Are Not in the Configuration Parameters of the FLF USLP VC Multiplexing FR.....	7-36
B-1 Words Commonly Used in the Names of Functional Resources and Their Associated PEDs	B-1

1 INTRODUCTION

1.1 PURPOSE OF THIS RECOMMENDED PRACTICE

This Recommended Practice defines the Functional Resource Model (FRM). Each Functional Resource (FR) is a model of an abstract function, which is usually associated with a specific layered standard and the functionality it provides within a communications system element. Each FR defines the parameters involved in the control and monitoring of the element. These FRs may be combined to model the elements of real deployed systems.

1.2 BACKGROUND

The FR concept was originally developed as a way to provide unique qualifiers for monitored parameter names in cases in which multiple instances of those parameters could be reported simultaneously through the Monitored Data Cross Support Transfer Service (MD-CSTS). A strawman set of FR Types was developed for the MD-CSTS (see reference [10]). The strawman FR Types were subsequently used (with modifications) to generate a proposed standard set of monitored parameters for each FR Type.

Fundamental to the concept of FRs is that each one represents a cohesive, atomic set of space communication functionality with which can be associated configuration parameters, monitored parameters, real-time control parameters, and event notifications.

FRs are not the physical resources (e.g., transmitters and receivers) that constitute real systems. Rather, they represent the functions that are provided by those physical resources. A functional resource may be realized by several physical entities that work cooperatively to perform that function. Alternatively, for some types of FRs, a single physical resource may be designed such that it instantiates several FRs.

The concept has subsequently been adopted as a core concept of the *Cross Support Transfer Service—Specification Framework* (CSTS SFW) (see reference [4]), with standard parameter names being defined as having an FR identifier component. The CSTS SFW also defines a registration subtree for FR Type Object Identifiers (OIDs) under the CCSDS registration tree (see the Space Assigned Numbers Authority [SANA] Functional Resources Registry, reference [22]). Besides monitored parameters, the FR registration tree defined in the CSTS SFW is used to register OIDs for *notifiable events* and *directives* associated with each FR Type. *Notifiable events* are also reported by the MD-CSTS. A *directive* is a control action that is invoked in real time. The directives are intended for use by a future Service Control CSTS (reference [39]) and possible other CSTSes.

The FR concept has been adopted as the basis for organizing the management information associated with the services to be managed via the planned *Cross Support Service Management—Service Agreement and Configuration Profile Formats* Recommended Standard (see reference [7]).

1.3 SCOPE

The scope of this Recommended Practice is to define all the functions that are required to implement a fully defined ABA ESLT, as defined in the Space Communications Cross Support (SCCS) Architecture (reference [13]). Specifically, this issue of this Recommended Practice addresses the following FRs:

- a) Aperture (Pointing and Weather Reporting);
- b) CCSDS 401 Space Link Carrier Transmission;
- c) Ranging Transmission;
- d) CCSDS 401 Space Link Carrier Reception;
- e) Range and Doppler Extraction;
- f) Delta-Differential One-way Ranging (DOR) Raw Data Collection;
- g) Open Loop Data Collection;
- h) Telecommand (TC) Physical Layer Operations Procedure (PLOP), Synchronization, and Channel Encoding;
- i) Telemetry (TM) Synchronization and Channel Encoding;
- j) TM Synchronization and Channel Decoding;
- k) TC Master Channel (MC) Multiplexing;
- l) TC Virtual Channel (VC) Multiplexing;
- m) Advanced Orbiting System (AOS) MC Multiplexing;
- n) AOS VC Multiplexing;
- o) Fixed Length Frame (FLF) Unified Space Link Protocol (USLP) MC Multiplexing;
- p) FLF USLP VC Multiplexing;
- q) Variable Length Frame (VLF) USLP MC Multiplexing;
- r) VLF USLP VC Multiplexing;
- s) TM/AOS MC Demultiplexing;
- t) TM/AOS VC Demultiplexing;
- u) FLF USLP MC Demultiplexing;
- v) FLF USLP VC Demultiplexing;
- w) Frame Data Sink;
- x) Tracking Data Message (TDM) Segment Generation;

- y) Non-Validated Radiometric Data Collection;
- z) Offline Frame Buffer;
- aa) TDM Recording Buffer;
- bb) Non-Validated Radiometric Data Store;
- cc) Validated Radiometric Data Store;
- dd) Delta-Differential One-way Ranging (Delta-DOR) Raw Data Store;
- ee) Forward Communication Link Transmission Unit (FCLTU) Transfer Service Provider;
- ff) Forward Frame CSTS (FF-CSTS) Provider;
- gg) Return All Frames (RAF) Transfer Service Provider;
- hh) Return Channel Frames (RCF) Transfer Service Provider;
- ii) Return Operational Control Field (ROCF) Transfer Service Provider;
- jj) Tracking Data CSTS Provider; and
- kk) Monitored Data CSTS Provider.

NOTES

- 1 The detailed definitions of the functional resources that address the above functionality are maintained in the SANA Functional Resources registry (reference [22]).
- 2 A subsequent version of this document will define all the functions required in an SSI ESLT, as defined in the SCCS-ADD (reference [13]).
- 3 As of this issue of this Recommended Practice, the coverage of CCSDS books in terms of Functional Resources is not exhaustive and will be extended in future versions (see annex E for a list of identified future functional resource sets).
- 4 As of this issue of this Recommended Practice, IOAG Service Catalog #2 services such as space internetworking services (references [29] and [30]) are not covered. It is expected that these will be added in a subsequent version.

1.4 APPLICABILITY

This Recommended Practice is applicable to ABA ESLT-provided cross support services that are based on CCSDS Cross Support Transfer Services and Cross Support Service Management that model functionality in terms of FRs.

The concepts and specifications of FRs, FR Sets, and FR Strata (see 3.1) may be applicable to other node types, but such applicability must be determined on an implementation basis.

1.5 RATIONALE

Multiple CCSDS cross support services use FRs as a core organizing paradigm for representing, in a uniform and implementation-independent way, the functionality of the numerous and various CCSDS Recommended Standards. This Functional Resource Model Recommended Practice and the SANA Functional Resources registry (reference [22]) define the collection of CCSDS standard cross support FRs in an organized and consistent manner so that they may be used as a reference in other standards.

1.6 DOCUMENT ORGANIZATION

Section 1 provides an overview of the various conceptual building blocks of the FRM.

Section 2 provides an overview of the FRM.

Section 3 describes the various concepts around which the FRM is organized. In particular, it describes the concept of FRs and the FR stratified model and Functional Resource Sets as vehicles for organizing those FRs.

Section 4 identifies and defines the FR Sets of the Aperture Functional Resource Stratum.

Section 5 identifies and defines the FR Sets of the Physical Channel FR Stratum.

Section 6 identifies and defines the FR Sets of the Synchronization and Channel Coding FR Stratum.

Section 7 identifies and defines the FR Sets of the Space Link Protocol FR Stratum.

Section 8 identifies and defines the FR Sets of the Space Link Session Data Delivery Production FR Stratum.

Section 9 identifies and defines the FR Sets of the Space Link Session Radiometric Data Production FR Stratum.

Section 10 identifies and defines the FR Sets of the Offline Data Storage FR Stratum.

Section 11 identifies and defines the FR Sets of the Data Transfer Services FR Stratum.

Section 12 identifies and defines the FR Sets of the Service Management Functions FR Stratum.

Section 13 identifies and defines the FR Sets of the Space Internetworking FR Stratum.

Annex A lists the Object Identifier offsets for the FR Strata and FR Sets.

Annex B lists abbreviations for construction of FR and parameter/event/directive classifiers.

Annex C addresses the security, SANA, and patent considerations that are applicable to this Recommended Practice.

Annex D lists the acronyms and abbreviations used in this Recommended Practice.

Annex E identifies existing, in-progress, and planned CCSDS Recommended Standards that will likely result in the specification of additional FRs and FR Sets in future issues of this Recommended Practice.

Annex F describes the procedures used in the maintenance of the FRM.

1.7 DEFINITIONS

1.7.1 TERMS DEFINED IN THE CROSS SUPPORT TRANSFER SERVICES SPECIFICATION FRAMEWORK (REFERENCE [4])

- a) Association Control procedure;
- b) blocking [operation];
- c) Buffered Data Processing procedure;
- d) complete [transfer mode];
- e) Cross Support Transfer Service (CSTS);
- f) Functional Resource (FR);
- g) latency-limit;
- h) procedure configuration parameter;
- i) qualified parameter;
- j) Sequence Controlled Data Processing procedure;
- k) service instance provision period;
- l) service management parameter;
- m) service-user-responding-timer;
- n) timely [transfer mode].

1.7.2 TERMS DEFINED IN THE CROSS SUPPORT REFERENCE MODEL (REFERENCE [1])

- a) Service Package;
- b) Space Link Session (SLS).

1.7.3 TERMS DEFINED IN THE SPACE COMMUNICATIONS CROSS SUPPORT ARCHITECTURE DESCRIPTION DOCUMENT (REFERENCE [13])

- a) ABA;
- b) Cross Support Service System (CSSS);
- c) Earth Space Link terminal ESLT;
- d) Earth User CSSS;
- e) Earth User Node (EUN);
- f) Element Management (EM);
- g) Provider CSSS;
- h) Provision Management (PM);
- i) Service Management (SM);
- j) Solar System Internet (SSI);
- k) Space User Node (SUN);
- l) Utilization Management (UM).

1.7.4 TERMS DEFINED IN ABSTRACT SYNTAX NOTATION ONE (REFERENCE [14])

- a) Abstract Syntax Notation One (ASN.1);
- b) Object Identifier.

1.7.5 TERMS DEFINED IN THE TC, AOS, AND USLP (REFERENCES [17], [18], AND [34])

- a) Communications Operation Procedure (COP) (reference [17] only);
- b) Global Virtual Channel Identifier (GVCID);
- c) Only Idle Data Frame (references [18] and [34] only);
- d) Master Channel (MC);
- e) Master Channel Identifier (MCID);
- f) Spacecraft Identifier (SCID);
- g) Transfer Frame (the format is specific to each Space Data Link Protocol [SDLP]);

- h) Transfer Frame Primary Header;
- i) Transfer Frame Version Number (TFVN);
- j) Virtual Channel VC; and
- k) Virtual Channel Identifier (VCID).

1.7.6 TERMS DEFINED IN THE TM SYNCHRONIZATION AND CHANNEL CODING RECOMMENDED STANDARD (REFERENCE [6])

- a) Attached Synchronization Marker (ASM);
- b) Channel Access Data Unit (CADU);
- c) Low-Density Parity-Check (LDPC);
- d) Low-Density Parity-Check coding of a stream of Sync-Marked Transfer Frames;
- e) Sync-Marked Transfer Frame (SMTF).

1.7.7 TERMS DEFINED IN THE COP-1 RECOMMENDED STANDARD (REFERENCE [37])

- a) Acceptance Check (Bypass Flag = 0) and Data (Control Command Flag = 0) (AD);
- b) Bypass of Acceptance Check (Bypass Flag = 1) and Control (Control Command Flag = 1) (BC);
- c) Bypass of Acceptance Check (Bypass Flag = 1) and Data (Control Command Flag = 0) (BD).

1.7.8 TERMS DEFINED IN THIS RECOMMENDED PRACTICE

- a) Functional Resource Set (see 3.2);
- b) Functional Resource Strata/Stratum (see 3.1);
- c) service configuration category (see 3.3).

1.8 NOMENCLATURE

1.8.1 NORMATIVE TEXT

The following conventions apply for the normative specifications in this Recommended Practice:

- a) the words ‘shall’ and ‘must’ imply a binding and verifiable specification;
- b) the word ‘should’ implies an optional, but desirable, specification;
- c) the word ‘may’ implies an optional specification;
- d) the words ‘is’, ‘are’, and ‘will’ imply statements of fact.

NOTE – These conventions do not imply constraints on diction in text that is clearly informative in nature.

1.8.2 INFORMATIVE TEXT

In the normative sections of this document, informative text is set off from the normative specifications either in notes or under one of the following subsection headings:

- Overview;
- Background;
- Rationale;
- Discussion.

1.9 COMPONENTS OF FUNCTIONAL RESOURCE DEFINITIONS

Sections 4 through 13 identify and define the FRs that constitute the FRM. These definitions are organized by FR Strata (where each section corresponds to an FR Stratum [see 3.1]) and by FR Sets (see 3.2) within those Strata. Only the FRs can have interfaces: either Service Access Points (SAPs) or ancillary interfaces.

For each FR Type that is defined in this Recommended Practice, the following information is specified:

- a) The corresponding FR Type classifier is listed. The FR Type classifier is the label of the unique OID for that FR Type. The FR Type OIDs are specified in the SANA Functional Resources registry (reference [22]), and the classifier serves as the key into that registry.

NOTE – The FR Type OIDs are registered under the `crossSupportFunctionalities` branch of the CCSDS Object Identifier Tree, which is specified in reference [4] as:

{ iso(1) identified-organization(3) standards-producing-organization(112)
ccsds(4) css(4) crossSupportResources(2) crossSupportFunctionalities(1)}

The FR Type OID for a given FR is therefore designated in the SANA Functional Resources registry by

{ iso(1) identified-organization(3) standards-producing-organization(112)
ccsds(4) css(4) crossSupportResources(2) crossSupportFunctionalities(1)
<Functional Resource Type classifier>...<FR Type OID part>}

where *FR Type OID part* is the distinguishing number of the that FR's OID.

- b) The status of the SANA Functional Resources registry information for the functional resource as of the current version of this Recommended Practice. The status can be either:
 - 1) Approved—the FR has to be registered in the SANA Functional Resources registry and can be used by operational systems (see 3.5.9); or
 - 2) Candidate—the FR has been posted to the SANA Functional Resources registry. It is assumed that the FR is under review. (See 3.5.9 for more details.)
- c) The specific functions of the pertinent CCSDS Recommended Standard(s) are identified.
 - 1) For each Recommended Standard cited as a source of FR functionality, (a) the FR definition addresses whether the Recommended Standard specifies the managed parameters associated with that functionality, and (b) if it does specify the managed parameters, the FR definition identifies any of those managed parameters that are *not* mapped to the configuration parameters for the standard defined by the FR and specifies how those managed parameters are set instead.

NOTE – Because of the application of information sharing (see 3.5.3 for further discussion of this), parameters that are defined in a Recommended Standard may have their values specified in an FR that is different from the FR that implements the functionality of that Recommended Standard, either directly or by derivation.
 - 2) If the FR performs multiple functions of the source Recommended Standard(s), a diagram of the internal structure of the FR is provided.
- d) Relationships of the functional resource with other functional resources outside the Functional Resource Set are identified in terms of:
 - 1) SAPs (see 3.4.2) that are accessible by external FRs;
 - 2) SAPs of external FRs that are accessed by the functional resource;
 - 3) ancillary interfaces (see 3.4.3) that are provided by the FR; and
 - 4) ancillary interfaces that are required by the FR (and if the ancillary interfaces are optionally required, the conditions under which they are required).

This Recommended Practice uses graphical conventions based on Unified Modeling Language (UML) (reference [15]) concepts and graphical notation to represent relationships among FRs. In particular, the UML concepts of composition, provided interfaces, and required interfaces, and their respective graphical notations, are used. The application of these UML concepts and graphical notations is described in 3.2 and 3.4.

1.10 REFERENCES

The following publications contain provisions which, through reference in this text, constitute provisions of this document. At the time of publication, the editions indicated were valid. All publications are subject to revision, and users of this document are encouraged to investigate the possibility of applying the most recent editions of the publications indicated below. The CCSDS Secretariat maintains a register of currently valid CCSDS publications.

- [1] *Cross Support Reference Model—Part 1: Space Link Extension Services*. Issue 2. Recommendation for Space Data System Standards (Blue Book), CCSDS 910.4-B-2. Washington, D.C.: CCSDS, October 2005.
- [2] *Space Link Extension—Return All Frames Service Specification*. Issue 5. Recommendation for Space Data System Standards (Blue Book), CCSDS 911.1-B-5. Washington, D.C.: CCSDS, July 2023.
- [3] *Space Link Extension—Return Channel Frames Service Specification*. Issue 4. Recommendation for Space Data System Standards (Blue Book), CCSDS 911.2-B-4. Washington, D.C.: CCSDS, July 2023.
- [4] *Cross Support Transfer Service—Specification Framework*. Issue 2. Recommendation for Space Data System Standards (Blue Book), CCSDS 921.1-B-2. Washington, D.C.: CCSDS, February 2021.
- [5] *TC Synchronization and Channel Coding*. Issue 3-S. Recommendation for Space Data System Standards (Historical), CCSDS 231.0-B-3-S. Washington, D.C.: CCSDS, (September 2017) July 2021.
- [6] *TM Synchronization and Channel Coding*. Issue 4. Recommendation for Space Data System Standards (Blue Book), CCSDS 131.0-B-4. Washington, D.C.: CCSDS, April 2022.
- [7] *Cross Support Service Management—Service Agreement and Configuration Profile Formats*. Recommendation for Space Data System Standards (Blue Book), CCSDS 902.5-B-1. Proposed.
- [8] *Cross Support Transfer Service—Tracking Data Service*. Issue 2. Recommendation for Space Data System Standards (Blue Book), CCSDS 922.2-B-2. Washington, D.C.: CCSDS, February 2023.

- [9] *IOAG Service Catalog #1*. Issue 2 revision 1. Washington, DC: IOAG, February 2017.
- [10] *Cross Support Transfer Services—Monitored Data Service*. Issue 2. Recommendation for Space Data System Standards (Blue Book), CCSDS 922.1-B-2. Washington, D.C.: CCSDS, September 2022.
- [11] *TC Synchronization and Channel Coding*. Issue 4. Recommendation for Space Data System Standards (Blue Book), CCSDS 231.0-B-4. Washington, D.C.: CCSDS, July 2021.
- [12] *Information Processing Systems—Open Systems Interconnection—Basic Reference Model—Part 4: Management Framework*. International Standard, ISO/IEC 7498-4:1989. Geneva: ISO, 1989.
- [13] *Space Communications Cross Support—Architecture Description Document*. Issue 1. Report Concerning Space Data System Standards (Green Book), CCSDS 901.0-G-1. Washington, D.C.: CCSDS, November 2013.
- [14] *Information Technology—Abstract Syntax Notation One (ASN.1): Specification of Basic Notation*. 5th ed. International Standard, ISO/IEC 8824-1:2015. Geneva: ISO, 2015.
- [15] *OMG Unified Modeling Language (OMG UML)*. Version 2.5.1. OMG Document Number: formal/2017-12-05. Needham, Massachusetts: Object Management Group, December 2017.
- [16] *IOAG Service Catalog #2*. Issue 1 revision 4. Washington, DC: IOAG, April 2021.
- [17] *TC Space Data Link Protocol*. Issue 4. Recommendation for Space Data System Standards (Blue Book), CCSDS 232.0-B-4. Washington, D.C.: CCSDS, October 2021.
- [18] *AOS Space Data Link Protocol*. Issue 4. Recommendation for Space Data System Standards (Blue Book), CCSDS 732.0-B-4. Washington, D.C.: CCSDS, October 2021.
- [19] *TM Space Data Link Protocol*. Issue 3. Recommendation for Space Data System Standards (Blue Book), CCSDS 132.0-B-3. Washington, D.C.: CCSDS, October 2021.
- [20] *Space Engineering—Ranging and Doppler Tracking*. ECSS-E-ST-50-02C. Noordwijk, The Netherlands: ECSS Secretariat, 31 July 2008.
- [21] *Sequential Ranging*. Module 203, Rev. D, July 17, 2019 in *DSN Telecommunications Link Design Handbook*. DSN No. 810-005, Rev. E. Pasadena California: JPL, November 30, 2000.
- [22] “Functional Resources.” Space Assigned Numbers Authority. https://sanaregistry.org/r/functional_resources.
- [23] *Radio Frequency and Modulation Systems—Part 1: Earth Stations and Spacecraft*. Issue 32. Recommendations for Space Data System Standards (Blue Book), CCSDS 401.0-B-32. Washington, D.C.: CCSDS, October 2021.

- [24] *Pseudo-Noise (PN) Ranging Systems*. Issue 3. Recommendation for Space Data System Standards (Blue Book), CCSDS 414.1-B-3. Washington, D.C.: CCSDS, January 2022.
- [25] *Data Transmission and PN Ranging for 2 GHz CDMA Link via Data Relay Satellite*. Issue 1. Recommendation for Space Data System Standards (Blue Book), CCSDS 415.1-B-1. Washington, D.C.: CCSDS, September 2011.
- [26] *CCSDS Spacecraft Identification Field Code Assignment Control Procedures*. Issue 7. Recommendation for Space Data System Practices (Magenta Book), CCSDS 320.0-M-7. Washington, D.C.: CCSDS, November 2017.
- [27] *Space Link Extension—Forward CLTU Service Specification*. Issue 5. Recommendation for Space Data System Standards (Blue Book), CCSDS 912.1-B-5. Washington, D.C.: CCSDS, July 2023.
- [28] *Space Link Extension—Return Operational Control Fields Service Specification*. Issue 4. Recommendation for Space Data System Standards (Blue Book), CCSDS 911.5-B-4. Washington, D.C.: CCSDS, July 2023.
- [29] *Rationale, Scenarios, and Requirements for DTN in Space*. Issue 1. Report Concerning Space Data System Standards (Green Book), CCSDS 734.0-G-1. Washington, D.C.: CCSDS, August 2010.
- [30] *IP over CCSDS Space Links*. Issue 1. Recommendation for Space Data System Standards (Blue Book), CCSDS 702.1-B-1. Washington, D.C.: CCSDS, September 2012.
- [31] *Delta-DOR Raw Data Exchange Format*. Issue 1. Recommendation for Space Data System Standards (Blue Book), CCSDS 506.1-B-1. Washington, D.C.: CCSDS, June 2013.
- [32] *Cross Support Transfer Service—Forward Frame Service*. Issue 1. Recommendation for Space Data System Standards (Blue Book), CCSDS 922.3-B-1. Washington, D.C.: CCSDS, April 2021.
- [33] “Service Sites and Apertures.” Space Assigned Numbers Authority. https://sanaregistry.org/r/service_sites_apertures.
- [34] *Unified Space Data Link Protocol*. Issue 2. Recommendation for Space Data System Standards (Blue Book), CCSDS 732.1-B-2. Washington, D.C.: CCSDS, October 2021.
- [35] “Spacecraft.” Space Assigned Numbers Authority. <https://sanaregistry.org/r/spacecraft>.
- [36] *Tracking Data Message*. Issue 2. Recommendation for Space Data System Standards (Blue Book), CCSDS 503.0-B-2. Washington, D.C.: CCSDS, June 2020.
- [37] *Communications Operation Procedure-1*. Issue 2. Recommendation for Space Data System Standards (Blue Book), CCSDS 232.1-B-2. Washington, D.C.: CCSDS, September 2010.

- [38] *Functional Resource Model Maintenance*. CCSDS Record (Yellow Book), CCSDS 901.4-Y-1. Forthcoming.
- [39] *Cross Support Transfer Services: Service Control*. Issue 1. Recommendation for Space Data System Standards (Blue Book), CCSDS 922.4-B-1. In development.
- [40] *Reference Architecture for Space Data Systems*. Issue 1. Recommendation for Space Data System Practices (Magenta Book), CCSDS 311.0-M-1. Washington, D.C.: CCSDS, September 2008.
- [41] *Functional Resource Registry at SANA*. Issue 1. CCSDS Record (Yellow Book), CCSDS 901.31-Y-1. Washington, D.C.: CCSDS, May 2024.
- [42] *Space Assigned Numbers Authority (SANA)—Role, Responsibilities, Policies, and Procedures*. Issue 3. CCSDS Record (Yellow Book), CCSDS 313.0-Y-3. Washington, D.C.: CCSDS, October 2020.

2 FUNCTIONAL RESOURCE MODEL OVERVIEW

2.1 GENERAL

The FRM is built upon the concepts of:

- FRs;
- FR stratified model;
- FR Sets;
- relationships among FR Sets; and
- service configuration categories.

This section describes the conceptual building blocks listed above.

2.2 FUNCTIONAL RESOURCES

2.2.1 FUNCTIONAL RESOURCES AS ABSTRACTIONS OF REAL RESOURCES

2.2.1.1 General

FRs are abstract representations of the functionality needed to provide space communication and tracking services, defined at a level of granularity sufficient to specify the configuration parameters, monitored parameters, and notifiable events associated with that functionality. FRs exist to represent such information as it applies to a cross support interface. If a processing function does not have unique monitored parameters, notifiable events, or any configuration parameters that need to be set (possibly through configuration profiles), queried, or reconfigured (via real-time control directives), then it does not have an FR to represent it. It should be noted that only one of these facets need be present for a function to need to be represented by an FR.

Figure 2-1 depicts a generic Functional Resource Type and its notional interfaces.

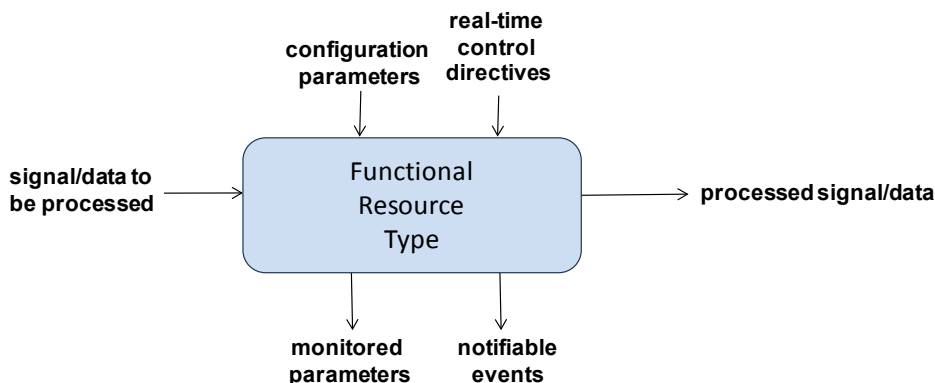

Figure 2-1: Notional Interfaces of the Generic Functional Resource Type

The horizontal interfaces represent the flow of data or a signal through an instance of the FR. The ‘function’ of the FR is the process that it performs on this signal/data. Such processing can involve converting one type of signal to another type of signal, manipulating data to produce another type of data, generating signals from data, or extracting data from signals (e.g., space communication data modulated onto an electromagnetic carrier signal, or Doppler data derived from an electromagnetic carrier signal). An FR instance is configured via the setting of the configuration parameters for its FR Type. When the FR instance is active, it emits measurements of whatever monitored parameters are defined for that FR Type. The FR instance also emits event notifications if any of the notifiable events that are defined for its FR Type occur. Finally, the behavior of an FR instance may be modified via the real-time control directives that are defined for its FR Type (if any).

Because FRs are abstractions, their relationships to the real physical resources that perform those functions are not specified in this Recommended Practice and will be mapped to real equipment at implementation stage and will vary from ESLT to ESLT. Also, the ‘interfaces’ by which the configurations are initially set and subsequently reconfigured, and by which parameters are monitored and events notified, are also abstract. The Element Management function(s) of any given ESLT have the (conceptual) responsibility for translating operations involving the Parameters, Events, and Directives (PEDs) of abstract functions’ resources into the actual interfaces of the real physical resources that implement those functional resources within that ESLT.

Whereas the identification of the FRs and their behavior are within the purview of this Recommended Practice, the SANA Functional Resources registry (reference [22]) is the official repository of (a) the identification and formal definitions of the PEDs of the functional resources and (b) the specifications of the various OIDs that are associated with those FRs and their PEDs. The contents of, and concepts that apply to, the SANA Functional Resources registry are described in 3.4.4.

2.2.1.2 Configuration and Control

As noted above, the real physical resources that implement physical resources can be configured and controlled, and the FR provides for this at the abstract level. Again, the translation of these events and directives from the abstract functions’ resources into real resources is the (conceptual) responsibility of the Element Management function(s) of any given ESLT.

Many configuration parameter values of an FR may also be changed during the execution of the Service Package by invoking the ‘set control parameters’ directive for that functional resource. Invocation of the ‘set control parameters’ directive on any given configuration parameter is subject to the guard conditions that are defined for that parameter. These guard conditions define the prerequisites for being able to change the value of the configuration parameter; if those conditions are not present, the directive will fail.

Directives provide the mechanism by which the User Mission may alter the behavior of functional resources during the execution of a Service Package, subject to guard conditions.

The CCSDS-standard directives may also be invoked by EM for purposes of local control within the Provider CSSS. There may also be additional, locally defined directives that are available only to EM. The specification of such EM-only directives is outside the scope of this Recommended Practice and the SANA Functional Resources registry.

Finally, in addition to the guard conditions and restrictions to dynamic reconfiguration defined as part of the CCSDS-standard definitions of the parameters, each Provider CSSS (e.g., Agency) may impose its own further restrictions on which parameters may have their values dynamically changed by UM through invocation of the ‘set control parameters’ directive, and on which other directives may be invoked by UM.

2.2.2 FUNCTIONAL RESOURCE TYPES

For the IOAG Service Catalog #1 services performed by an Earth Space Link Terminal (which is the current scope of SCCS SM), the composite functionality includes:

- a) the transmission/reception of the signal on the space link with the Space User Node;
- b) the channel synchronization and coding/decoding of the data on that space link;
- c) the execution of the space link protocols; and
- d) the provision of the cross support services by which the User missions submit data destined for their Space User Node and receive data from their Space User Node.

This functionality nominally conforms to the specifications provided by CCSDS Recommended Standards for space link modulation (reference [23]), synchronization and channel coding (references [5] and [6]), SDLPs (references [17], [18], [19], and [34]), and terrestrial cross support services (references [2], [3], and [10]).

It is expected, as previously noted, that future revisions of this document will be extended to cover IOAG Service Catalog #2 services such as space internetworking services (references [29] and [30]).

The services provided in a Service Package can contain multiple instances of FR Types. Each FR Type is assigned an International Organization for Standardization (ISO) OID, which is referred to as the *Functional Resource Type*. The FR Type is used to construct unique identifiers for FR instances and for the monitored parameters, configuration parameters, notifiable events, and real-time control directives that those functional resources expose. An FR instance is identified by its Functional Resource Name, which is the combination of the Functional Resource Type with a Functional Resource Instance Number. (See the *Cross Support Transfer Service—Specification Framework*, reference [4], for additional details on the formal syntax of FR identifiers.)

3 FUNCTIONAL RESOURCE MODEL CONCEPTS

3.1 FUNCTIONAL RESOURCE STRATA

NOTE – Parts of this section use the modeling and terminology of *Space Communications Cross Support Architecture Description Document* (reference [13]). The SCCS-ADD terms that are applicable to the FRM are:

- *Cross Support Service Element, (CSSE)*: A physical element involved in providing one or more cross support services (including functions for managing services).
- *Earth Space Link Terminal (ESLT)*: The CSSE that provides space communication services between the Earth User Node and the Space User Node. It includes the ground station control and management systems. The ESLT has space link protocol interfaces and supports terrestrial SLE and CSTS interfaces. The ESLT also has a service management interface that is controlled by the UE that is responsible for managing the space link. Here it also applies to the combination of ground stations and relay satellite in bent-pipe relay satellite systems, that is, in which the relay satellite is the aperture of the ground station from the perspective of the Space User Node.
- *Space User Node* is the ADD term for the user Mission element in space, for example, mission spacecraft, planetary rover.
- *Earth User Node* is the ADD term for a terrestrial facility of the user Mission, and in particular one that hosts users of ESLT services.
- *Provider CSSS* is the ADD term for a Tracking, Telemetry, and Command (TT&C) network, including the service management functions.

To categorize the types of functionality that the various FRs perform, and to help clarify what categories of functions are needed to perform a given service, this FRM establishes the *Functional Resource stratified model*. The FR stratified model is similar to the layered models for ISO Open Systems Interconnection (seven layers) and Transmission Control Protocol (TCP)/Internet Protocol (IP) (four layers), in which each layer is defined abstractly so that multiple specific protocols can be plugged in, as long as they meet the definition of that layer. In the case of the FR stratified model, the ‘lowest’ stratum provides the physical link (in this case, an electromagnetic carrier signal) between the ESLT and a Space User Node and the ‘higher’ strata perform the intermediate processing of data that is exchanged between the ESLT and an Earth User Node that is associated with that Space User Node. The FR stratified model has the following strata:

- a) Aperture (RF, Optical, or hybrid RF/Optical), which is the physical interface to the space medium. On the ‘ground side’, the aperture receives and/or transmits an electromagnetic carrier signal.
- b) Physical Channel, which transfers a stream of channel symbols through the aperture across the physical medium (in this case, space). In addition to the transfer of a stream

of symbols, the physical channel may also carry non-binary signals, for example, for the purpose of range measurements. The space physical channel has traditionally been provided at radio frequencies using Radio Frequency (RF) modulation techniques, but the use of optical physical channels is expected to increase.

NOTE – In any realization of a space link, the technology used by the aperture must be compatible with the technology used by the physical channel. However, the possibility for multiple aperture technologies' being applicable to the same physical channel technology (e.g., a single-feed steerable antenna, an array of geographically separated steerable antennas, an array of fixed antenna elements that 'point' by adjusting the phase differences among those antenna elements) justifies treating apertures separately from physical channels for the purposes of FR Strata definition.

- c) Synchronization and channel coding, which consists of the error coding, randomization, and synchronization functions that are performed to convert space data link transfer frames to the bit streams that are transferred across the space physical channel, and vice versa.
- d) SDLPs that insert/extract space-optimized Protocol Data Units (PDUs) into/from space data link transfer frames and in some cases control the flow of those transfer frames across the space link.
- e) Data delivery transfer services that allow remote user mission entities to interface with the ESLT for the purpose of exchanging data with their respective Space User Node via the space links provided by the ESLT. These services include SLE Transfer Services, CSTSes, and application-level services that transform data on the way to or from the Space User Node.
- f) Offline data storage, used to hold data when the transfer of data to or from the Space User Node cannot occur at the same time (or at the same data rate) as that of the space link over which the data is to be transported.
- g) Internetworking protocols that provide end-to-end connectivity across multiple kinds of data links, including space links (to be addressed in a future revision of this document).

NOTE – Space Internetworking is part of IOAG Service Catalog #2 capabilities.

For the IOAG Service Catalog #1 services performed by an ESLT (which is the current scope of this FRM), the composite functionality of these abstract strata conforms to the specifications provided by CCSDS Recommended Standards for space link modulation (reference [23]), synchronization and channel coding (references [5] and [6]), SDLPs (references [17], [18], [19], and [34]), and terrestrial cross support transfer services (references [27], [2], [3], [28], [32], [10], and [8]).

Figure 3-1 depicts the set of FR Strata for the ESLT and the possible data flows through them. As illustrated in the figure, many combinations of FR Strata are possible, although most services will each use only a single flow through the strata.

NOTES

- 1 The possible flows shown in figure 3-1 are the space communications and radiometric service data flows through these FR Strata. They do not include the flows by which the resources within these strata are configured and controlled in real time and by which monitored parameter values and event notifications are collected from the resources in these various strata for reporting to the Earth User Node. Such data flows can be considered to occur in a separate management dimension (see the paragraph describing the Service Management Functions Stratum below).
- 2 Figure 3-1 includes a Space Internetworking Stratum, even though space internetworking is an IOAG Service Catalog #2 capability and outside the current scope of this Recommended Practice. This stratum is included to illustrate how space internetworking can be accommodated within the FR stratified model.
- 3 Although the set of strata identified in this Recommended Practice encompasses all services of IOAG Service Catalog 1 (and, in principle, Service Catalog 2, although those services are not dealt with in this issue of this document) new SCCS services that do not easily fit into the strata defined herein may be introduced in the future. If that happens, new strata will be defined in a way that provides the same kinds of extensibility as the strata described in this Recommended Practice.

The IOAG services are distributed across multiple strata to align with the IOAG service categories defined in Service Catalogs #1 and #2 (references [9] and [16], respectively). IOAG services are categorized into *data delivery services* (forward and return), *radiometric services*, and *Service Management Functions*. The data delivery and radiometric service groups are further divided into the *space link interfaces* and *ground link interfaces* of which they are composed.

The set of strata that correspond to the Space Link Interface Standards are the Aperture, Physical Channel, Synchronization and Channel Coding, and Space Link Protocol FR Strata. By definition, these strata are present only in Space Link Session (SLS) configurations (see 3.3.2).

- The Aperture Stratum represents the general class of apertures through which forward space link signals are transmitted and return space link signals are received as part of SLS Service Packages. Some apertures can be used by multiple forward and/or return space links simultaneously, although specific types may be limited in directionality and/or number of simultaneous links.
- The Physical Channel Stratum represents the RF modulation, (future) optical modulation, and radiometric measurement functions that are performed as part of SLS Service Packages.
- The Synchronization and Channel Coding Stratum represents the coding/decoding and synchronization functions that are performed as part of SLS Service Packages.
- The Space Link Protocol Stratum represents the space link protocol processing functions that are performed as part of SLS Service Packages.

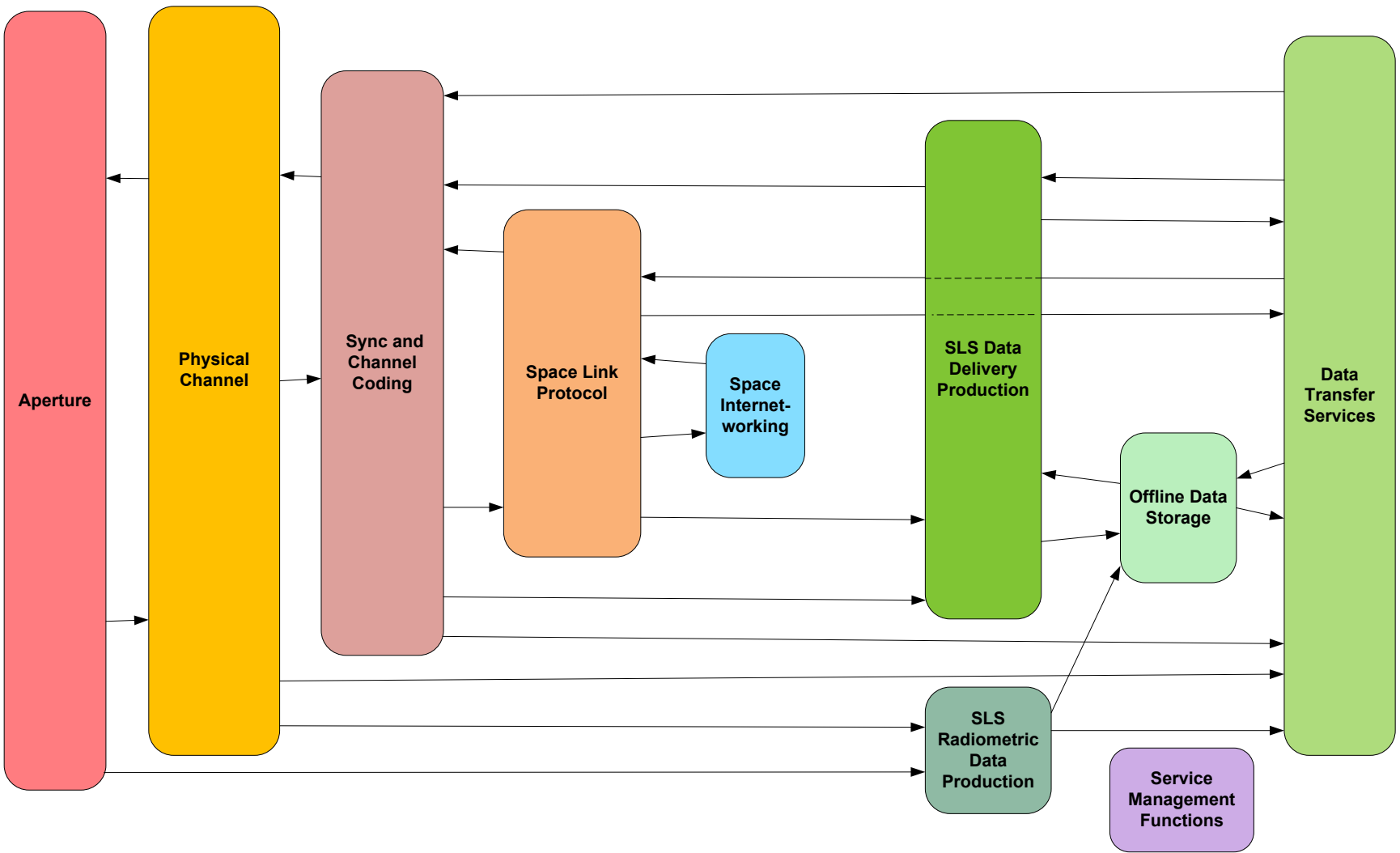

Figure 3-1: Functional Resource Strata for Earth-Space Link Terminals

The strata that correspond to the ground link interfaces of the CCSDS data delivery and radiometric services are the SLS Data Delivery Production Stratum, the SLS Radiometric Data Production Stratum, the Offline Data Storage Stratum, the Data Transfer Services Stratum, and the Space Internetworking Stratum.

- The SLS Data Delivery Production Stratum represents the additional production functions (beyond those provided by the Aperture, Physical Channel, Synchronization and Channel Coding, and/or Space Link Protocol Strata) that are performed as part of SLS Service Packages. For forward-link data, the SLS Data Delivery Production Stratum functions provide the additional processing needed to transmit data that is either transferred in real time via a Data Delivery transfer service or extracted from intermediate storage. For return-link data, the SLS Data Delivery Production Stratum functions provide the additional processing needed to prepare the data for either intermediate storage and/or real-time delivery via a Data Transfer service.
- The SLS Radiometric Data Production Stratum represents the additional production functions (beyond the Aperture and Physical Channel Strata radiometric measurement functions) that are performed as part of SLS Service Packages in order to prepare radiometric data for intermediate storage and/or real-time delivery via a Radiometric Data transfer service.
- The Offline Data Storage Stratum represents the production functions that are performed as part of Retrieval Service Packages (for return-link communication and radiometric data) or a Store and Forward Service Package (for forward-link communication data). For return-link data, these functions include (but are not necessarily limited to) the data stores and recording buffers that hold data awaiting subsequent retrieval. For forward-link data, these functions include (but are not necessarily limited to) the data stores that hold data awaiting subsequent transmission during a space link session.
- The Data Transfer Services Stratum represents the various cross support transfer services that are used to transfer space link communication data and radiometric data across terrestrial networks between an Earth User Node and an ESLT. These services include the SLE transfer services, CSTSes that transfer communication data that will be sent or that has been received through the space link, services that transfer radiometric data from the ESLT to the Earth User Node, and services that transfer files of communication data that will be sent or that has been received through the space link.
- The Space Internetworking Stratum represents functions performed to transfer internetwork data across the space link as part of an end-to-end internetwork data transfer. IOAG Service Catalog #1 (reference [9]) does not include internetwork services; those are covered by Service Catalog #2 (reference [16]). This stratum is included, as a place marker, in the set of ESLT strata for accommodation of Space Internetworking services in Cross Support Service Management in the future.

The Service Management (SM) Functions Stratum corresponds to the IOAG SM functions. There are two transfer services that belong to the SM Functions Stratum: the MD-CSTS and the future Service Control (SC) CSTS. As noted above, the SM Functions interface with functions in all of the other strata via connections that exist in a management dimension that is not illustrated in figure 3-1.

The FR Strata do not have specific configuration parameters, monitored parameters, notifiable events, or real-time control directives. It is the specific Functional Resource Types within concrete *Functional Resource Sets* within the strata for which parameters, events, and directives are defined.

3.2 FUNCTIONAL RESOURCE SETS

As described previously, the Functional Resource stratified model is similar to the ISO Open Systems Interconnection (OSI) seven-layered reference model: by itself, it is abstract and incapable of being implemented, but it provides a framework for organizing the various FR Types. A set of FR Types that collectively perform the functions that are ascribed to a Functional Resource Stratum is a *Functional Resource Set*.

Figure 3-2 depicts the Functional Resource Sets that are addressed by this issue of this Recommended Practice. To the greatest extent possible, each of these FR Sets corresponds to a CCSDS Recommended Standard. Within the rounded box for each stratum, the FR Sets of that stratum are depicted as dashed-border rounded boxes. In two cases (SLS Radiometric Data Production and Offline Data Storage), the strata boxes are not large enough for all of the FR Sets. In these cases, the FR Sets are shown in separate boxes at the bottom of the diagram.

NOTE – In figure 3-2 and subsequent figures that depict the FR Sets that specialize the FR Strata, the placement of the FR Set icons within the FR Strata icons is not related to the position of the arrows entering and leaving the containing parent icons. The figures merely indicate that the FR Sets belong to their parent FR Strata. However, for those FR Strata that have both transmission and reception FR Sets, the transmission FR Sets are shown in the upper part of the FR Strata icons, and the reception FR Sets are shown in the lower part of the FR Strata icons.

The functionality of a Functional Resource Set is provided by the FR(s) that make up that Functional Resource Set. The FR Types that make up each of the Functional Resource Sets are identified in subsequent sections of this Recommended Practice.

When a Functional Resource Set contains two or more FR Types, the relationships among the functional resources in the same Functional Resource Set are expressed as UML *containment* relationships. These containment relationships represent the flow of data or information among the functional resources within the Functional Resource Set. By convention, the containment relationships flow *away from the space link*. This convention is driven by the multiplexing and demultiplexing nature of space link communications, where multiple user data flows are multiplexed across the space link. For example, a master channel multiplexer FR instance contains multiple virtual channel multiplexer FR instances, and a master channel demultiplexer FR instance contains multiple virtual channel demultiplexer FR instances.

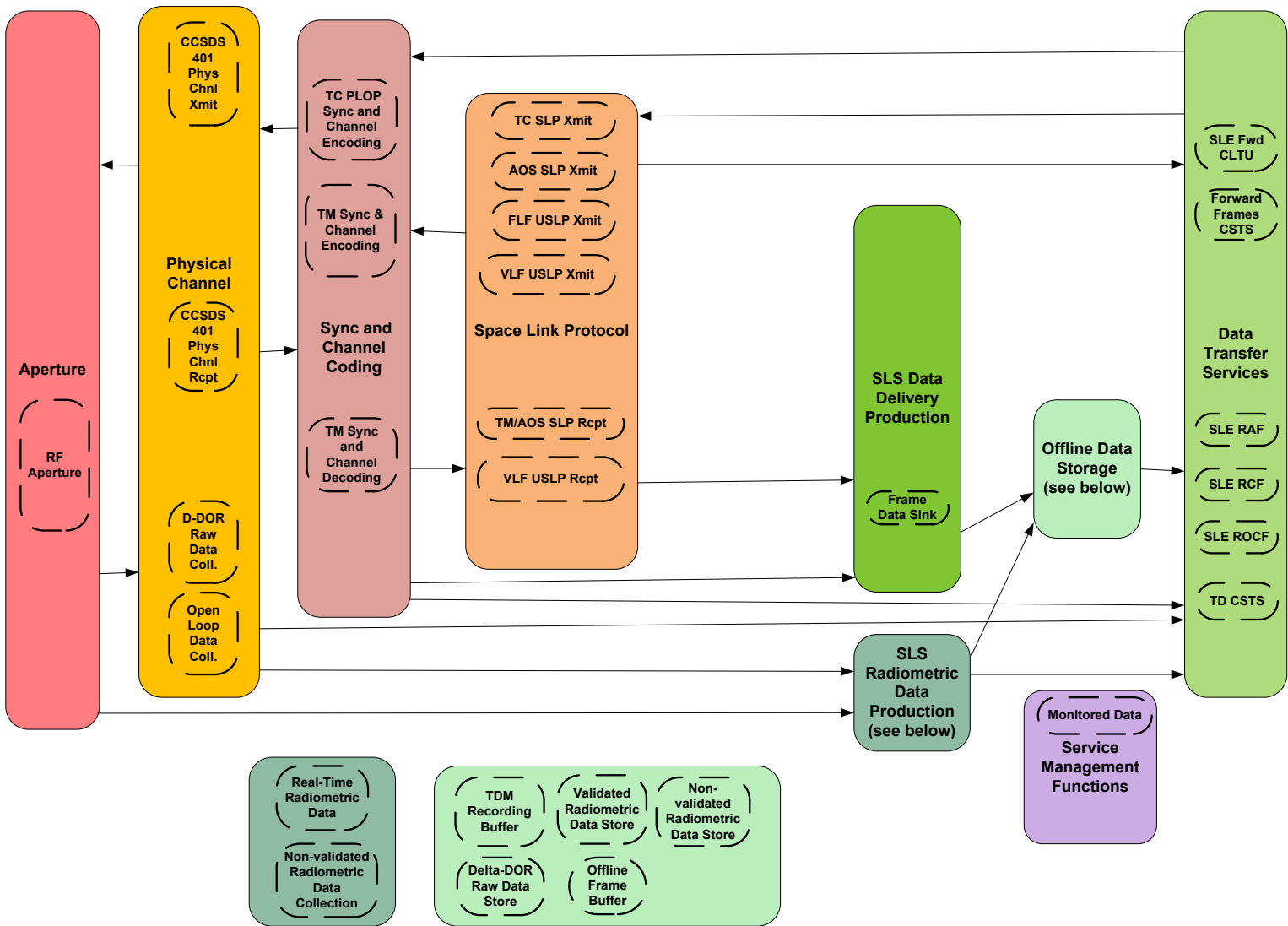

Figure 3-2: Functional Resources Sets within the Strata

3.3 SERVICE CONFIGURATION CATEGORIES

3.3.1 GENERAL

For SM purposes (e.g., service agreements, configuration profile definition, and scheduling), the FR Sets (and the FRs they comprise) are used in three categories of configurations:

- a) the SLS configuration category, which comprises the functions of the ESLT that:
 - 1) transfer data to or from one or more Space User Nodes across one or more space links during an SLS,
 - 2) provide forward and/or return data transfer services during an executing SLS so that one or more Earth User Nodes communicate with the Space User Node(s) with end-to-end connectivity in ‘real time’, and
 - 3) extract radiometric measurements from space links of an active SLS and deliver those measurements to the destination Earth User Node in ‘real time’;
- b) the retrieval configuration category, which comprises the functions of the ESLT that:
 - 1) deliver data that was received from a Space User Node to an Earth User Node, but not necessarily during the execution of the SLS by which the data was received, and
 - 2) deliver radiometric measurements to the Earth User Node, but not necessarily during the execution of the SLS during which the radiometric measurements were extracted;
- c) the forward offline data delivery configuration, in which the ESLT receives and stores data from an Earth User Node destined for a Space User Node, before the execution of the SLS by which the data is transmitted to the Space User Node.

These configuration categories are reflected in the service agreements, space link service profiles, and configuration profiles to be defined in reference [7].

3.3.2 SLS CONFIGURATION CATEGORY

Figure 3-3 illustrates the FR Strata and FR Sets that are used in the SLS configurations. The SLS configuration category involves all of the FR Strata for ESLTs, but only part of the functionality of the following strata is used for the provision of services during an SLS:

- a) The Data Transfer Services Stratum is limited to those services that allow Earth User Nodes to interface with the ESLT for the purpose of (1) exchanging data with their respective Space User Nodes in real time via the space links provided by the ESLT and (2) receiving radiometric data in real time. These SLS CSTSes include online SLE Transfer Services (see reference [1]) and real-time CSTSes (see reference [4]).
- b) The Offline Data Storage Stratum is constrained to those functions associated with (1) receiving and storing data from Space User Nodes for subsequent transfer to Earth User Nodes and (2) storing radiometric data for subsequent transfer to Earth User Nodes.

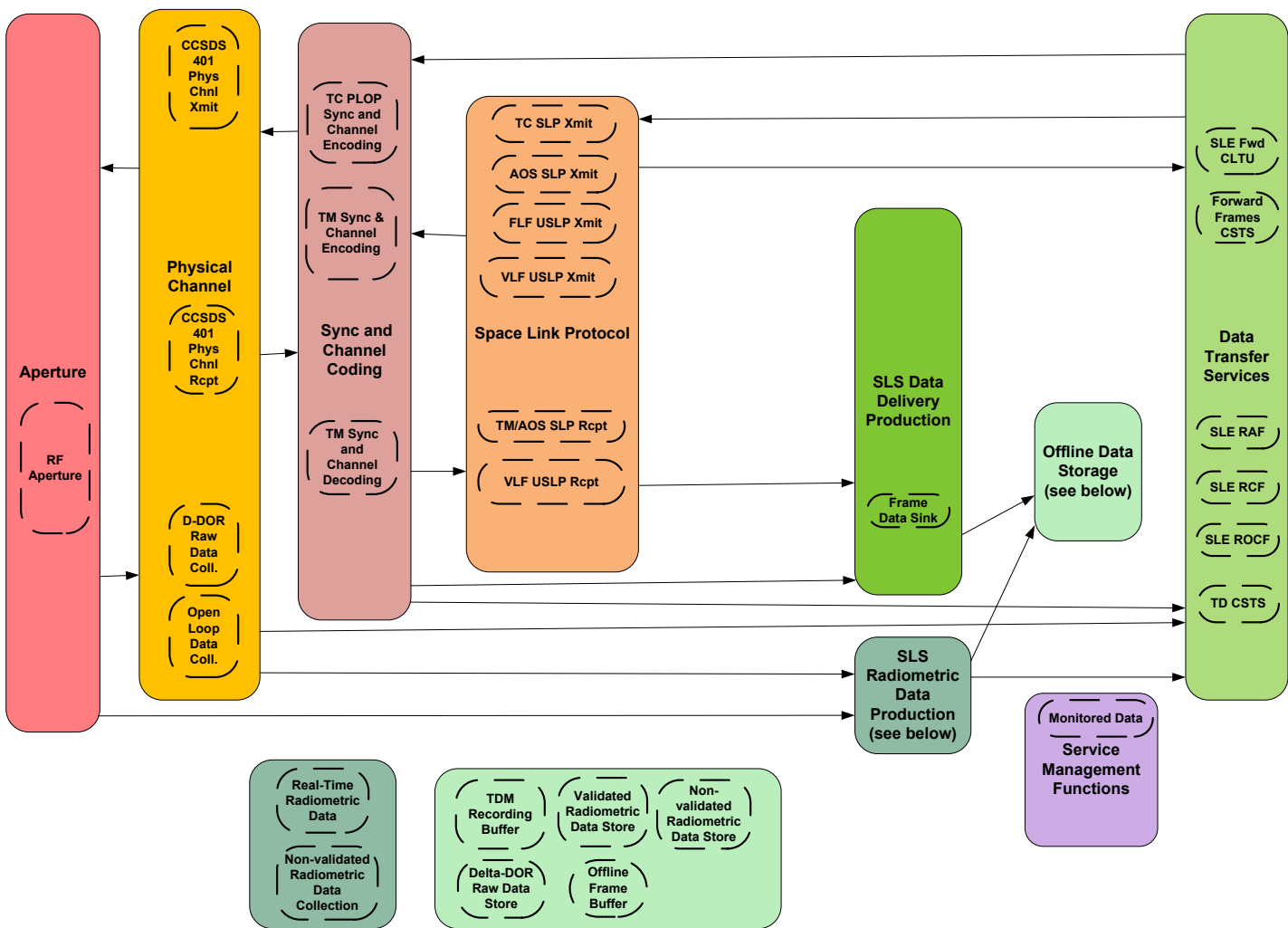

Figure 3-3: Functional Resource Strata Used in SLS Configurations

3.3.3 RETRIEVAL CONFIGURATION CATEGORY

The retrieval configuration category does not require the above space link communications stack, although in some cases the space link stack may be present. The minimal retrieval configuration is composed of an Offline Data Storage FR Set and a Data Transfer Services FR Set. The data transfer services that are included in the retrieval configuration category in this issue of this Recommended Practice consist of the SLE RAF, RCF, and ROCF Transfer Services (see references [2], [3], [28]) operating in offline mode and the Tracking Data CSTS (see reference [8]) operating in complete mode.

Figure 3-4 shows the FR Sets within the FR Strata used in the retrieval data delivery and retrieval radiometric data configurations and the connectivity among the FR Sets within those strata.

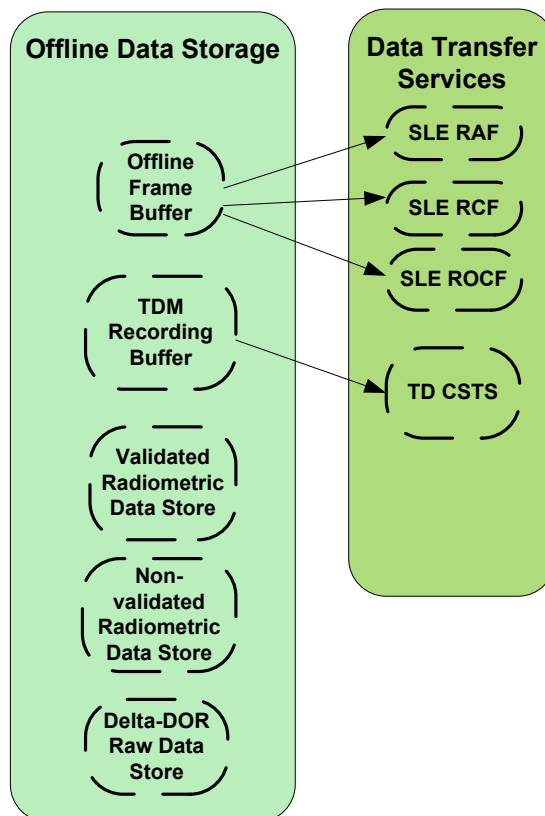

Figure 3-4: Functional Resource Strata and FR Sets Used in Retrieval Configurations

NOTE – Although the scope of this issue of this Recommended Practice includes the Non-Validated Radiometric Data Store, Validated Radiometric Data Store, and Delta-DOR Raw Data Store FR Sets, there are not yet standard cross support definitions for the automated delivery of the files in these data stores (see 10.4, 10.5, and 10.6).

3.3.4 FORWARD OFFLINE DATA DELIVERY CONFIGURATION

The forward offline data delivery configuration does not involve the space link communications stack. It is composed of a forward offline CSTS and a forward space link data store.

There are no Functional Resource Sets that participate in the forward offline data delivery configuration in this issue of this Recommended Practice.

3.3.5 FUNCTIONAL RESOURCE SET CONNECTIVITY

Figure 3-5 shows the connectivity among the Functional Resource Sets.

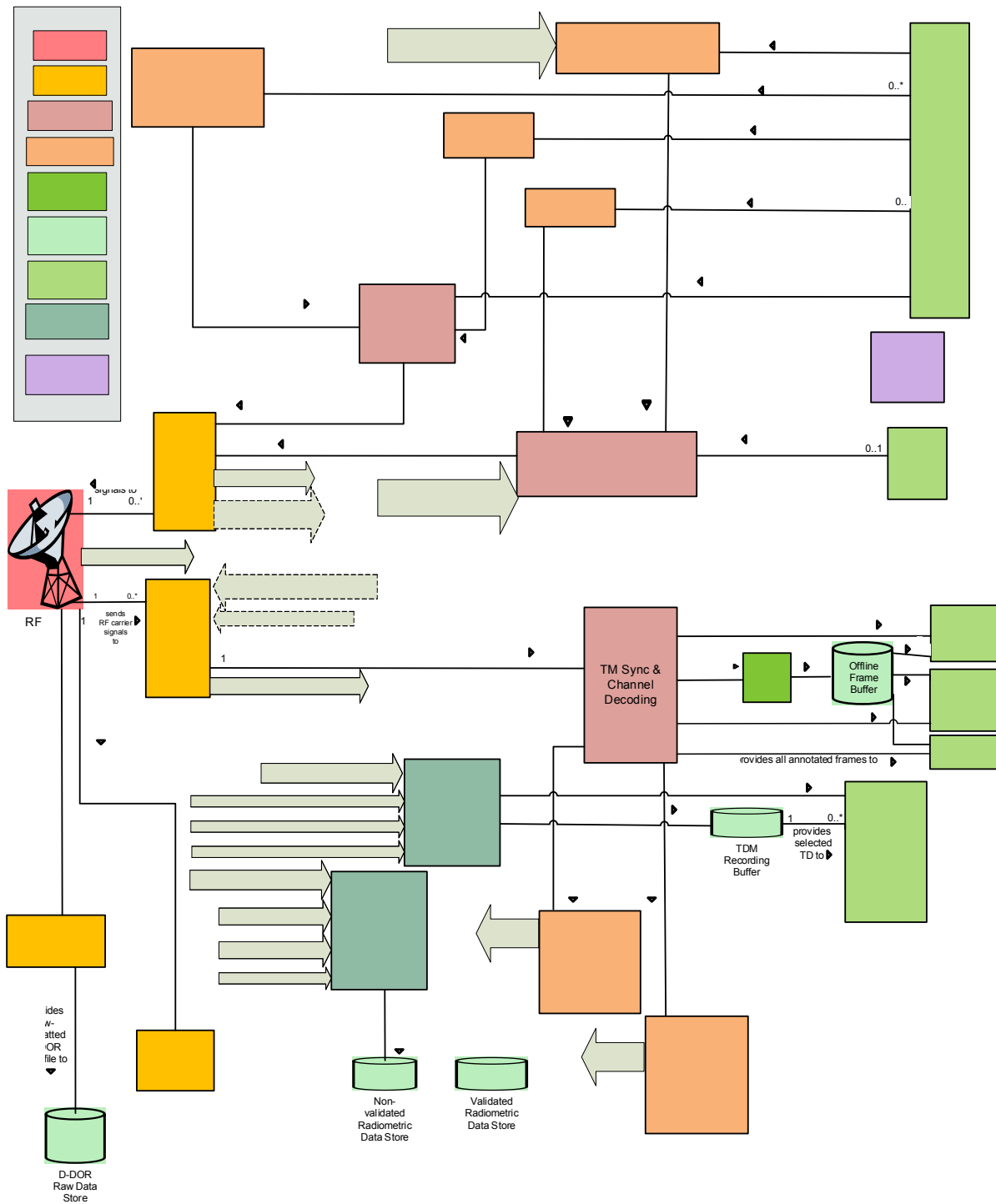

Figure 3-5: Functional Resource Set Connectivity

3.4 RELATIONSHIPS AMONG AND WITHIN FUNCTIONAL RESOURCE SETS

3.4.1 GENERAL

There are two kinds of relationships between functional resources within and among FR Sets: relationships in which a functional resource provides a SAP that is accessed by another functional resource, and relationships in which a functional resource provides an ancillary interface (see 3.4.3) that is required by another functional resource. The principal use of SAP relationships and provided/required interfaces is to establish the necessary ‘wiring’ among FR instances in Configuration Profiles and Service Packages.

3.4.2 SERVICE ACCESS POINTS AND ACCESSORS

In the relationship between the FR Sets in two interacting strata, the FRs of an FR Set provide SAPs to FRs in another FR Set. One FR is the *Accessor* of that SAP, the other FR is the *Provider* of the SAP.

NOTE – In the SAP/Accessor context, ‘service’ refers to the service that an FR provides to the another FR. It is not to be confused with ‘service’ in the sense of SLE or Cross Support ‘transfer services’ or ‘space link services’ such as telemetry, command, and tracking.

The SAP/Accessor relationships are also the essential relationships between FRs within any FR Set that contains multiple FRs or among FRs contained in different FR Sets. Usually, the associations between a SAP and its Accessors is used to identify a relationship in which user data flows from one FR to the other within the ESLT.

However, SAP/Accessor associations may also represent other kinds of relationships among FRs, for example, an FR whose sole purpose is to extract directives from a metadata file in order to issue those directives to another FR for the purpose of controlling the behavior of that other FR. The first FR has an existential dependency on the second FR; the only reason that the first FR exists is because the second FR exists. The first FR therefore has a SAP/Accessor relationship with the second FR. It should be noted that in this example, there may also be other essential relationships, for example, the relationships between the second FR and other FRs that represent the user data flow for which the processing performed by the second FR is being shaped by the directives invoked by the first FR.

Sections 4 through 13 define the FRs in each FR Set within each FR Stratum. For each FR Set, a diagram is provided that represents the FRs that make up that FR Set and the SAP and Accessor roles of each FR (as appropriate). The diagrams use the following graphical notion to depict the SAP and Accessor roles in the essential relationships among FR instances.



This is the graphical notation used in UML (reference [15]) to represent *composition*, where the filled diamond end represents the composite class or object, and the arrow end represents

a component class/entity of that composite class/entity. Cardinality is also expressed using the UML conventions; that is, A and B can take the following values:

- *, or 0..*: zero, one, or many instances;
- 0..*n*: zero or up to *n* instances, but no more than *n*;
- *n*: exactly *n* instances;
- *n*..*: *n* or more than *n* instances.

For purposes of this FRM, use of composition to express these relationships represents the essential, existential relationship between the FRs; the Accessor FR exists only when the SAP FR exists. The semantics of UML composition specify that if the compound object is not present, neither are its component objects. In terms of space communication and radiometric services, if one layer of the protocol stack is missing, then all layers that exist above that layer are also missing. The composition begins with the FRs at the space link and ‘moves’ toward the ground interface with the user. A forward space link carrier must have an aperture in a viable space link service profile. However, the opposite is not necessarily true: an aperture can function in a space link service profile without a forward space link carrier, as in the cases of receive-only data and/or tracking operations.

NOTE – One aspect of the semantics of UML composition that does not quite fit the FRM usage is that, strictly speaking, an FR class is not actually composed of the FR classes ‘below’ it. For the purposes of the FRM, this aspect is not important and is ignored.

3.4.3 REQUIRED AND PROVIDED ANCILLARY INTERFACES

In addition to the primary SAP/Accessor relationships, FRs may also have ancillary relationships that provide information that facilitates the proper functioning of those FRs. For example, the provision of transmission frequency information by an FR that generates the forward carrier on one FR Set to the FR that receives the return carrier when the return carrier is coherent to the forward carrier is an instance of an ancillary interface between FRs. Another example is the relationship by which Communications Link Control Words (CLCWs) are extracted from return-link transfer frames and used on the forward link to regulate the PLOP on the forward link. These ancillary relationships are represented as *provided* and *required interfaces*. The FR that generates the information has the provided interface, and the FR that consumes the information has the required interface. For the first example above, the FR that generates the forward carrier has the provided interface for transmit frequency information, and the FR that transmits the return carrier has the required interface for transmit frequency information. For the second example above, the FR that extracts CLCWs from return-link transfer frames has the provided interface for CLCWs, and the forward-link FR that uses the CLCWs to regulate the PLOP has the required interface.

Provided/required interfaces are also used to represent relationships in which there is no existential dependency of one FR on a single other FR. For example, the Tracking Data Cross Support Transfer Service (TD-CSTS, reference [8]) is capable of reporting multiple types of

radiometric data from multiple FRs concurrently. At least one of these FRs must be present to provide its type of radiometric data to the FR that combines the data into the TDMs that are delivered by the TD-CSTS, but there is no single radiometric data source FR Type that is essential to the existence of the TD service; any one (or more) of several such FR Types is sufficient. The relationships between the individual radiometric data source FRs and the FR that combines the data into the TDMs are therefore represented by provided/required interfaces, where *if* the TDM generation function is configured to report a given type of radiometric data, *then* it requires an interface with an FR that provided that radiometric data type.

The FR Set diagrams use the following graphical notation to represent the provided and required interfaces:

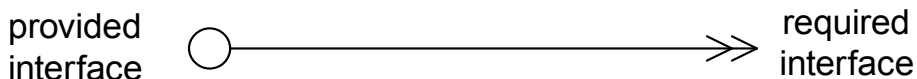

NOTE – This representation is derived from the UML ‘ball and socket’ icons for provided/required interfaces, where the ball represents the provided interface, and the socket represents the required interface. However, the graphical tools available to the author of this Recommended Practice are unable to generate the proper ball-and-socket icons, so instead, this Recommended Practice substitutes the double arrow end for the socket as the representation of the required interface.

3.4.4 EXTERNAL SERVICE INTERFACES

External Service Interfaces are represented as shown below:

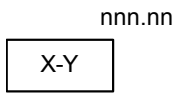

where:

- X can take the following values:
 - M for ‘Management’,
 - T for ‘Transfer’;
- Y can take the following values:
 - P for ‘Provider Service Port’,
 - U for ‘User Service Port’;
- nnn.nn is the number of the CCSDS book that provides the detailed description of the external service interface.

3.5 SANA FUNCTIONAL RESOURCES REGISTRY

3.5.1 OVERVIEW

The SANA Functional Resources registry (reference [22]) is the official repository of the OIDs that are assigned to the CCSDS standard cross support FRs, the semantic definitions of those FRs, the identification and formal definitions of the PEDs of those FRs, and the OIDs that are associated with those PEDs.

NOTES

- 1 The semantic definitions of the FRs given in the SANA Functional Resources registry have sufficient detail to prescribe the behavior of the FRs. Further background on the FRs is supplied in sections 4 through 13 of this Recommended Practice by way of references to specific standards and specifications.
- 2 The FRM data used to populate and format the SANA Functional Resources registry is generated using an FRM Editor and maintained in an eXtensible Markup Language (XML)-formatted database. In addition to rendering the FRM data in the formats presented in the SANA Functional Resources registry, the FRM Editor is also capable of rendering the FRM data into formats suitable for use by other purposes such as SM Configuration Profiles. (See reference [38] for more information.)

The SANA Functional Resources registry populates the `crossSupportFunctionalities` node of the CCSDS OID registration tree: { iso(1) identified-organization(3) standards-producing-organization(112) ccstds(4) css(4) crossSupportResources(2) crossSupportFunctionalities(1)}.

NOTE – In addition to the CCSDS-standard cross support FRs that are registered under the `crossSupportFunctionalities` node of the CCSDS OID registration tree, Agency-specific FRs may be registered under the `agenciesFunctionalities` node: { iso(1) identified-organization(3) standards-producing-organization(112) ccstds(4) css(4) crossSupportResources(2) agenciesFunctionalities(2)}. Subsection 3.5.9.2 addresses the contents of the `agenciesFunctionalities` node.

The SANA Functional Resources registry is organized by FR Type, that is, by the OIDs assigned to the FRs (see 2.2.2). However, the OIDs under the `crossSupportFunctionalities` node contain an internal structuring by FR Strata (see 3.1), then by FR Sets (see 3.2) within those strata, and finally by FRs within those FR Sets. This internal structuring is accomplished by giving the OID digits under the `crossSupportFunctionalities` node FR Strata *OID offsets* that begin with 10000 (for the Aperture FR Stratum) and increment by 10000 for each subsequent stratum (e.g., the Physical Channel Stratum has the OID offset 20000). Within each FR Stratum, the FR Sets are given OID offsets that begin with 100 and increment by 100; for example, the RF Antenna FR Set within the Aperture FR Stratum has the OID offset 10100. Annex A lists the OID offsets for the FRs that are contained under the `crossSupportFunctionalities` node. Within each FR Set, the component FRs are assigned OIDs, with the OID of the root FR being set to the OID of the FR Set itself and subsequent FRs within the FR Set assigned OIDs that increment by 1. Thus the Antenna FR, which is the

only FR within the RF Antenna FR Set (and is therefore also the root FR of that FR Set) has the OID digit 10100, which results in the full OID for the Antenna FR being:

```
{ iso(1) identified-organization(3) standards-producing-organization(112) ccstds(4) css(4)
crossSupportResources(2) agenciesFunctionalities (2) Antenna(10100)}.
```

This scheme allows for the possibility of future definition of FR Strata with up to 99 FR Sets within each stratum, and up to 100 FRs within each FR Set. The presence of the FR Strata and FR Set structure is implicit in the OID of each FR even though the Strata and the FR Set identifiers do not appear explicitly in the registration tree.

3.5.2 GENERAL

For each FR, the following shall be specified:

- a) the *OID* of the FR;
- b) the *element type* (FR/P/E/D/Q/V);
- c) the *semantic definition* of the FR;
- d) the *classifier* of the FR (i.e., the ‘short name’ of the FR [e.g., Ccsds401SpaceLinkCarrierXmit]);
- e) the *string identifier* of the FR (i.e., the ‘long name’ of the FR [e.g., ccstds-401-space-link-carrier-xmit]);
- f) the *version* of the FR definition;
- g) whether the FR is *deprecated*;
- h) the parameters of the FR;
- i) the events of the FR; and
- j) the directives of the FR.

NOTE – Reference [41] provides further details.

3.5.3 FUNCTIONAL RESOURCE PARAMETERS

3.5.3.1 For each parameter of an FR, the SANA Functional Resources registry shall specify the following:

- a) the *OID* of the parameter;
- b) the *type OID* of the parameter;
- c) the *external type OID* of the parameter;

- d) the *element type* (FR/P/E/D/Q/V);
- e) the *semantic definition* of the parameter;
- f) the *classifier* of the parameter;
- g) the *string identifier* of the parameter;
- h) the *version* of the parameter definition;
- i) whether the parameter is *deprecated*;
- j) the *engineering unit(s)* of the parameter;
- k) the *type definition* of the parameter, expressed in ASN.1;
- l) whether or not the parameter is *configured*; and
- m) *guard conditions* (if any) on the configuration (setting) of the parameter value (applicable only when configured = true).

NOTE – Reference [41] provides further details.

3.5.3.2 The *configuration parameters* input in figure 2-1 corresponds to SANA Registry parameters that are designated as configured = true. By definition, all parameters of an FR are monitorable, and so the *monitored parameters* output in figure 2-1 corresponds to all parameters, whether they are configured or not.

NOTE – When a CSTS such as the Monitored Data Cross Support Transfer Service (reference [10]) reports FR parameter values, each parameter value is encapsulated within a *qualified parameter* (see annex C of reference [4]) that not only reports the parameter value, but a qualifier for that value: ‘valid’, ‘unavailable’, ‘undefined’, or ‘error’. The type definition of the FR parameter that is specified in the SANA Functional Resources registry is the data type that applies to the parameter when the qualifier is ‘valid’.

3.5.3.3 Several concepts apply to the identification and definition of FR configuration parameters. The first is the concept of information sharing among FRs in the same operational configuration. Often, a parameter value will be applicable to multiple FRs in an operational configuration. For example, the VC multiplexer FR, MC multiplexer FR, and synchronization and channel encoding FR for a given fixed-length-frame-carrying physical channel must all operate with frames of the same length. Defining a frame length configuration parameter for each of these FRs would require that each of these frame length parameters be set to the same value in the configuration profile that represents the chain of functionality associated with that physical channel, introducing redundancy and the possibility of inconsistent settings. Under the concept of information sharing, only one FR instance contains the common parameter, and the other FRs in the same configuration profile share that common parameter value as necessary. The common configuration parameter is allocated to the lowest-common FR Type in which the parameter is always applicable. In some cases, a configuration parameter is derived from other configuration parameters, either

within the same FR or within other FRs in the same configuration profile. In the example of frame length, the (fixed or maximum) frame length that is used by the FRs that generate and multiplex frames can be derived from the CADU or Communication Link Transmission Unit (CLTU) size parameter plus the coding options that are configured in the synchronization and coding FR that is associated with those other FRs.

3.5.3.4 Such shared configuration parameter values are propagated throughout an operational configuration as necessary to ensure that all functionality is configured in accordance with those values. Returning to the fixed frame length example, the shared frame length parameter value is specified as a configuration parameter of an instance of the TM Synchronization and Channel Encoding (TmSyncAndChnlEncode) FR. If there are any FF-CSTS instances associated with that TmSyncAndChnlEncode FR instance, that shared frame length value is used to validate incoming frames by all of those FF-CSTS instances. If there are any frame generation FR instances associated with that TmSyncAndChnlEncode FR instance, that shared frame length value is used to set the length of the frames generated by all of those frame generation FR instances.

3.5.3.5 A consequence of the information sharing approach for FR configuration information is that it is assumed that all FRs in a configuration will be consistent with each other, and therefore no exception-handling behavior needs to be specified for FRs regarding consistency errors (such as frames of different lengths being input to the same fixed-length-frame multiplexer).

3.5.4 FUNCTIONAL RESOURCE EVENTS

3.5.4.1 For each event of an FR, the SANA Functional Resources registry shall specify the following:

- a) the *OID* of the event;
- b) the *element type* (FR/P/E/D/Q/V);
- c) the *semantic definition* of the event;
- d) the *classifier* of the event;
- e) the *string identifier* of the event;
- f) the *version* of the event definition;
- g) whether the event is *deprecated*; and
- h) the *value* of the event, which comprises:
 - 1) the *type OID*;
 - 2) the *external type OID*;
 - 3) the *element type* (FR/P/E/D/Q/V);
 - 4) the *semantic definition* of the event value;

- 5) the *classifier* of the event value;
- 6) the *string identifier* of the event value;
- 7) the *version* of the event value definition;
- 8) whether the value is *deprecated*;
- 9) the *engineering unit(s)* of the event value; and
- 10) the *type definition* of the event value, expressed in ASN.1.

NOTE – Reference [41] provides further details.

3.5.4.2 In general, the event values are the values of existing parameters. For example, the value of the *resourceStatusChange* event is the new value of the *resourceStatus* parameter for that FR. In these cases, the type definition of the event value and the source parameter value are the same (e.g., ResourceStat).

3.5.5 FUNCTIONAL RESOURCE DIRECTIVES

3.5.5.1 For each directive of an FR, the SANA Functional Resources registry shall specify the following:

- a) the *OID* of the directive;
- b) the *element type* (FR/P/E/D/Q/V);
- c) the *semantic definition* of the directive;
- d) the *classifier* of the directive;
- e) the *string identifier* of the directive;
- f) the *version* of the directive definition;
- g) whether the directive is *deprecated*;
- h) *guard condition(s)* (if any) on the directive; and
- i) the *qualifier* of the directive, which comprises:
 - 1) the *type* OID;
 - 2) the *external type* OID;
 - 3) the *element type* (FR/P/E/D/Q/V);
 - 4) the *semantic definition* of the directive qualifier;
 - 5) the *classifier* of the directive qualifier;
 - 6) the *string identifier* of the directive qualifier;

- 7) the *version* of the directive qualifier definition;
- 8) whether the qualifier is *deprecated*;
- 9) the *engineering unit(s)* of the directive qualifier; and
- 10) the *type definition* of the directive qualifier, expressed in ASN.1.

NOTE – Reference [41] provides further details.

3.5.5.2 Every FR has a set control parameters directive (`xxxSetContrParams`) that allows the User Mission to reset the value of configuration parameters during the execution of the Service Package. The directive qualifier of the `xxxSetContrParams` directive contains the identification of the parameters that are to be modified and their new values. The set of configuration parameters that are eligible to be modified using this directive is under control of the individual Provider CSSS and identified as such in service offering information and service agreements.

3.5.6 FUNCTIONAL RESOURCE STATUS

3.5.6.1 Every FR (except SLE Transfer Service Provider and CSTS Provider FRs) has a *resource status* parameter (`xxxResourceStat`) that reports the operational status of the resource(s) represented by that FR instance. The values of the resource status shall be:

- ‘configured’: the resource has been configured, but is not yet operational;
- ‘operational’: the resource is performing its function(s);
- ‘interrupted’: a failure has been detected that prevents the resource from performing its function(s);
- ‘halted’: the resource has been taken out of service by local management (i.e., by EM).

NOTE – From the perspective of the User Mission, the resource status of an FR is a read-only parameter. However, stimuli that cause an FR’s resource status to change can include directives from the Provider CSSS’s EM, for example, a directive to transition the resource from ‘operational’ to ‘halted’. Any EM directives that relate to the resource status are within the purview of the individual EM and outside the scope of CCSDS standardization.

3.5.6.2 In addition to the `xxxResourceStat` parameter, each FR has the notifiable event `xxxResourceStatChange`, which shall be emitted upon the change of the resource status. The event value of the `xxxResourceStatChange` event is the status of the resource following the change.

3.5.7 TRANSFER SERVICE PROVIDER FUNCTIONAL RESOURCE PRODUCTION STATUS

3.5.7.1 Each SLE Transfer Service Provider and CSTS Provider FR shall have a *production status* parameter (`xxxProdStat`) that represents the collective resource status of the FRs that support that data transfer service instance. While the semantics of the production status are particular to each transfer service type, in general, if all FRs that support a transfer service instance are operational, then the production status is ‘operational’; if any support FR is halted, then the production status is ‘halted’, and so on. As with the resource status of the individual FRs, the production status of a transfer service is read only from the perspective of the User Mission.

3.5.7.2 In addition to the `xxxProdStat` parameter, each SLE Transfer Service Provider and CSTS Provider FR shall have the notifiable event `xxxProdStatChange`, which is emitted upon the change of the production status. The event value of the `xxxProdStatChange` event is the production status of the transfer service FR following the change.

3.5.8 CSTS PROVIDER FUNCTIONAL RESOURCE CONFIGURATION CHANGE

Every CSTS Provider FR shall have a ‘production configuration change’ event that is emitted when a configuration parameter of any of the FRs that support that CSTS instance changes value that applies to the production of that service instance. Such configuration changes can occur as a result of an invocation of the EXECUTE-DIRECTIVE operation (for CSTSes with EXECUTE-DIRECTIVE capability), a parameter change caused by the future Service Control CSTS; and a parameter change directed by a Sequence of Events. The ‘production configuration change’ event carries no event value.

3.5.9 DISCUSSION

3.5.9.1 SANA CCSDS-Standard Cross Support Functional Resource Registries

The SANA Functional Resources registry is available online at https://sanaregistry.org/r/functional_resources. It contains Approved specifications for the FRs that are defined in this Recommended Practice. The SANA Functional Resources registry contains both Approved and Candidate FR definitions.

Approved FR specifications are recommended for use in cross support situations. They are identified as being Approved by the identification of the approval authority (e.g., ‘Cross Support Services Area’) in the *authorizing entity* attribute of the specification.

Candidate FR specifications are in the process of being reviewed and are not recommended for use in cross support situations. Candidate FR specifications are identified as being Candidate by a blank entry in the *authorizing entity* attribute of the specification. When a

Candidate FR specification has been reviewed and approved, the *authorizing entity* attribute is updated in the SANA Functional Resources registry.

3.5.9.2 SANA Agency-Defined Functional Resource Registration

As noted earlier in this document, the FRs that are defined herein are the CCSDS-standard cross support FRs that are registered under the crossSupportFunctionalities node of the CCSDS OID registration tree: { iso(1) identified-organization(3) standards-producing-organization(112) ccsds(4) css(4) crossSupportResources(2) crossSupportFunctionalities(1)}.

Individual Agencies may wish to create and register their own fictional resources and associated PEDs, such that the real resources represented by those FRs can take advantage of the cross support service infrastructure that relies on the FR concept (e.g., the Monitored Data, Tracking Data, and Service Control CSTSes, and Space Communication Cross Support SM). For example, an Agency may provide a legacy service that is not based on CCSDS Recommended Standards and that has no reason to become a CCSDS-standard service. Such a service, with appropriate instrumentation, could be monitored using the Monitored Data CSTS.

The CCSDS OID registration tree accommodates the registration of Agency-defined FRs and their respective PEDs under the agenciesFunctionalities node:

{ iso(1) identified-organization(3) standards-producing-organization(112) ccsds(4) css(4) crossSupportResources(2) agenciesFunctionalities(2)}.

Under the agenciesFunctionalities node, each Agency may be allocated its own node by first requesting designated control authority over such a node. Once the Agency has received the designated control authority, that Agency may define additional FRs and associated PEDs, for which the object identifiers OIDs are allocated in accordance with D6.3 of reference [4].

Although each Agency is responsible for creating the definitions of their FRs, as specified in H2.4 of reference [4], the Cross Support Services Area (CSSA) serves as the Review Authority for Agency-defined FRs. As such, the CSSA reviews proposed FRs prior to registration to ensure consistency and non-overlap with existing FR definitions. Once approved by the Review Authority, the Agency-defined FRs are published by SANA.

Although the only formal requirements on the definition of Agency-defined FRs are specified in D6.3 of reference [4], Agencies are encouraged to follow the structure and information content of the CCSDS-standard cross support FRs described in 3.5.2 through 3.5.6 to the greatest extent reasonable.

3.5.9.3 Conceptual Model of Functional Resource Interactions

As described earlier, the FR is an abstraction that allows the physical resources of a node to be represented in a standard and uniform way. The FR concepts are inspired by the concepts of ISO OSI Systems Management (see reference [12]). In the OSI Systems Management

model, the real resources of an enterprise are represented by a collection of standardized *managed objects*. Managed objects are abstractions that represent idealized groups of functions that are performed by the real resource of the enterprise. Each managed object has a standardized set of controllable and monitorable attributes (i.e., parameters), events emitted by the managed object, and operations that can be invoked on the managed object. By definition, this standard set is of interest to management. Depending on the implementations of a real resource, it may be represented by a single managed object or several managed objects, or its functionality may be combined with that of other resources and the combined functionality represented by a single managed object. The *management agent* (or, simply, *agent*) of a managed object marshals the resource or resources that perform the functionality ascribed to the managed object such that it appears to management as though the managed object encapsulates the resources that perform that functionality. Each *managed object class* has a standardized set of attributes, event, and operations. The collection of attributes, events, and operations for all managed object classes for all managed object classes used by an enterprise constitutes the *Management Information Base* (MIB) for that enterprise. If a real resource has been designed and implemented to support the standard MIB for the managed object functions that it performs, the agent functionality is embedded in the real resource, and the resource interacts directly with management. However, if a real resource does not map easily into a managed object, and/or if the real resource has its own, non-standard set of parameters, events, and operations, then a *proxy agent* is needed to perform the translations/transformations necessary between the standardized set and the resource-specific attributes, events, and operations.

The CCSDS FR is analogous to the OSI managed object in that it is an abstract representation of the real resources used to accomplish space data communications and navigation. The SANA Functional Resources registry is essentially the MIB for the FRs.

As with the OSI Systems Management model, the representation of FRs as having one-to-one relationships with real space data system resources is an idealization. In a real implementation, the functionality that is represented by an FR may be performed by a real physical resource that performs the functions of multiple FRs, by multiple real physical resources, or by some combination thereof. It is also possible (and likely if there is not a one-to-one relationship between FR and physical resource) that the physical resource(s) do(es) not natively support the FR PEDs that are defined for its associated FR(s), but instead have non-CCSDS-standard (possibly implementation-specific) PEDs that can be translated and/or transformed into the CCSDS-standard PEDs. In such a case, a proxy agent will be needed to mediate the interface between the affected resources and Element Management. The proxy agent may be collocated (physically or logically) with the physical resources that it represents, or it may reside remotely from the represented physical resource(s). In either case, the interface(s) between the proxy agent and the physical resource(s) that it represents are implementation specific and outside the scope of this Recommended Practice.

Figure 3-6 illustrates the conceptual model for an ESLT that is executing a Service Package that is transmitting TC frames using the FF-CSTS (reference [32]). The example also includes an instance of the MD-CSTS (reference [10]) and the future Service Control CSTS.

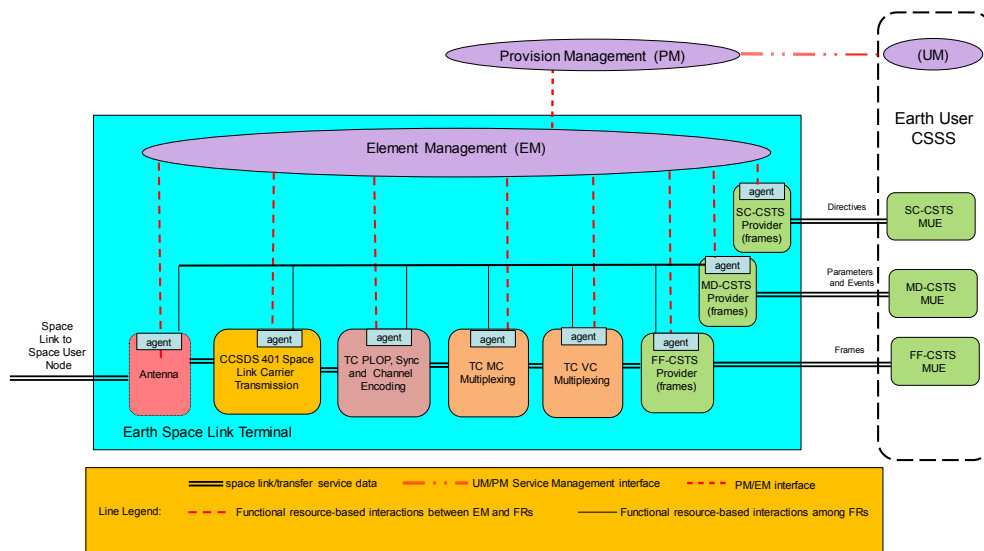

Figure 3-6: Functional Resource Conceptual Model of Interaction

In this conceptual model, each managed system has a one-to-one mapping to an FR Type, and each has an embedded agent. The Mission’s Configuration Management (CM) function interacts with the Provider C/SSS’s PM function to schedule a Service Package that executes the configuration profile that transmits the TC frames received by the ESLT through the FF-CSTS. PM transfers the Service Package information to the EM function of the ESLT that is to execute the Service Package using interface(s) and protocol(s) that are locally defined by the Provider C/SSS and outside the scope of this Recommended Practice.

EM selects the managed systems that will be used to host the FRs in the configuration and configures those FRs through the embedded FR agents. The interfaces used between EM and the embedded FR agents are standardized to the extent that they are expressed in terms of CCSDS-standard PEDs but are otherwise implementation-specific and outside the scope of this Recommend Standard.

When Service Package execution begins and the FF-CSTS instance is bound and active, the user of the FF service is able to query the values of parameters of not only the FF-CSTS Provider instance itself but also the values of the parameters of the FR instances that form the production chain for that FF service instance. The supporting production FRs also emit event notifications (such as the ‘data processing complete’ event that is emitted by the TC PLOP, Synchronization, and Channel Encoding FR to indicate that the frame has been transmitted) that either moderate the functions of the FF-CSTS Provider or are relayed to the service user. In the conceptual mode, these parameter values and event notifications are exchanged directly among the agents of the FF-CSTS Provider FR and the supporting production FRs, as represented by the virtual network represented by the *functional resource-based interactions among FRs* lines in the diagram. The implementation of such a virtual network is outside the scope of this Recommended Practice.

The FF-CSTS may also issue directives to underlying production FRs, triggered either by directives from the service user or by the processes performed by the FF-CSTS Provider FR itself. However, because directives must, in general, be checked against guard conditions that

may involve multiple FR instances in the production chain, all directives are sent to EM for guard condition validation, and valid directives are sent from EM to the affected FR instances.

When the MD-CSTS instance is bound and active, the user of the MD service is nominally able to query the values of the parameters of all of FR instances in the Service Package, subject to Service Agreement constraints. As with the exchange of parameter values and event notifications with the FF-CSTS Provider FR, in the conceptual mode, the parameter values and event notifications are exchanged directly among the agents of the MD-CSTS Provider instance and the FRs, including the FF-CSTS Provider FR.

When the SC-CSTS instance is bound and active, the user of the SC service is nominally able to issue directives to trigger actions and change the values of the configuration parameters of all FR instances in the Service Package, subject to Service Agreement constraints. As with the invocation of directives by the FF-CSTS Provider FR, all directives are sent to EM for guard condition validation, and valid directives are sent from EM to the affected FR instances.

Now can be considered a non-ideal (although probably more realistic in the near term) implementation/deployment, in which the physical resources do not necessarily relate one-to-one to their FR Types and not all managed systems have resident FR agents. Figure 3-7 is an example of such an implementation/deployment, which implements the proxy agents as part of EM.

In this example, only the CSTS Provider FRs have built-in FR agents. The other FRs are implemented by managed systems that have management interfaces native to their design. Also, the TC MC Multiplexing and TC VC Multiplexing FRs are implemented by the same physical resource, which has one native management interface that configures and controls the functions of both FRs.

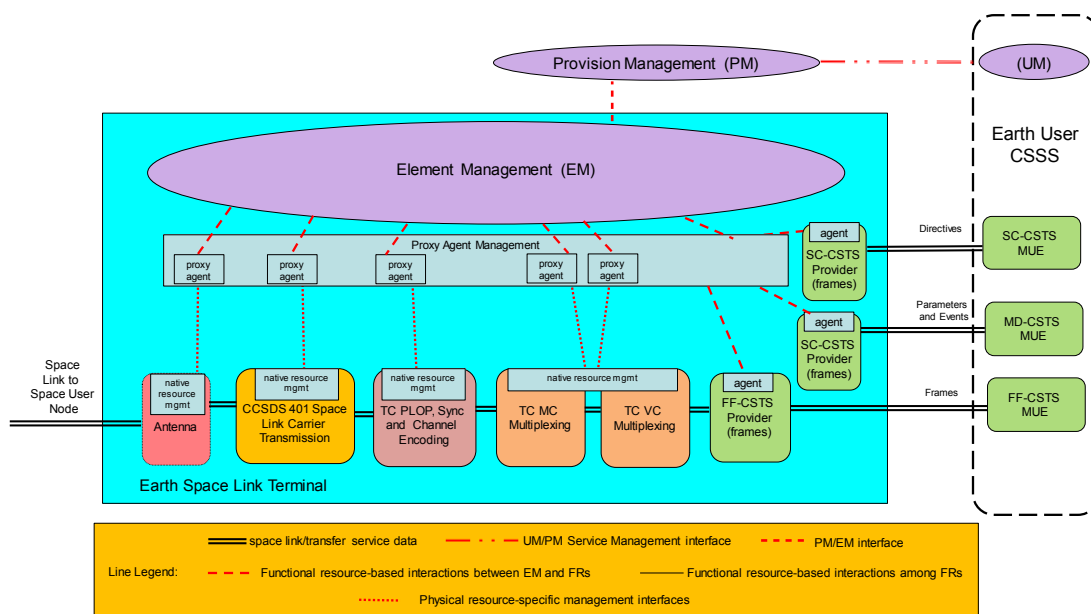

Figure 3-7: Functional Resource Mixed Architecture Example

In this example, EM performs various proxy-agent management functions that collectively make the managed resources appear and act as FRs. These proxy functions include instantiating proxy agents for each of the managed systems that do not have embedded FR agents. Each proxy agent translates/transforms between the CCSDS-standard FR PEDs and the PEDs that are native to the managed system for which it is acting as a proxy. The proxy agent management functions also interface with the FR agents of those managed systems that have embedded FR agents. Finally, the proxy-agent management functions provide the virtual interconnection network between the agents and proxy agents that allows for the exchange of parameters and events among the FRs and for the invocation and guard-condition validation of directives.

4 APERTURE FUNCTIONAL RESOURCE STRATUM

4.1 GENERAL

The Aperture FR Stratum has one FR Set:

- RF Aperture.

4.2 RF APERTURE FUNCTIONAL RESOURCE SET OF THE APERTURE FUNCTIONAL RESOURCE STRATUM

4.2.1 GENERAL

The RF Aperture FR Set of the Aperture Stratum shall consist of the Antenna FR.

NOTE – Figure 4-1 illustrates the composition of the RF Aperture FR Set.

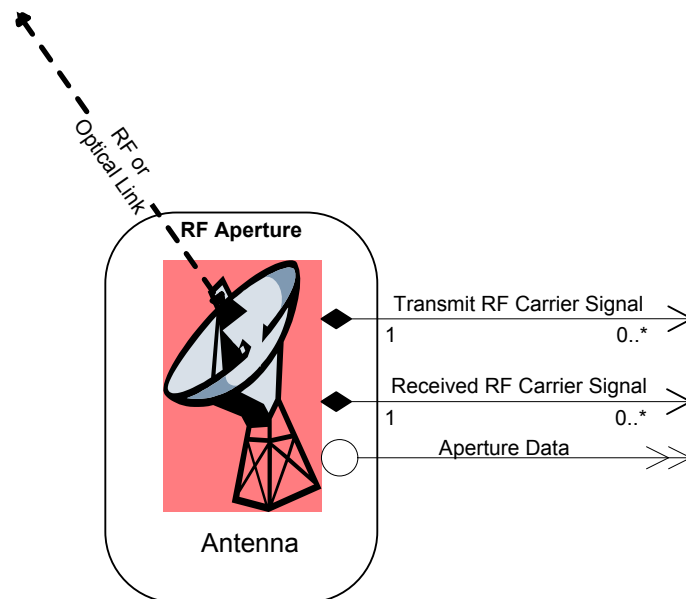

Figure 4-1: Member Functional Resource of the RF Aperture Functional Resource Set

4.2.2 ANTENNA

4.2.2.1 General

4.2.2.1.1 The classifier of the Antenna FR Type is *Antenna*.

4.2.2.1.2 In transmitting signals, the Antenna FR accepts as input the RF carrier signal from an FR in the Physical Channel FR Stratum and radiates that signal either into space or into a water load, provided the given Antenna FR instance has the transmit capability.

4.2.2.1.3 In receiving signals, the Antenna FR provides as output the RF carrier signal received from space to one or more signal reception FRs in the Physical Channel FR Stratum, provided the given Antenna FR instance has the receive capability.

4.2.2.1.4 Azimuth and Elevation (AZEL) pointing angles and Slant Total Electron Count (STEC) measurements are forwarded to one or more FRs of the SLS Radiometric Data Production FR Stratum. The pointing angles are provided only while the antenna is in some form of ‘closedLoop’ pointing mode.

4.2.2.1.5 For the correction of radiometric observables, tropospheric and weather data are required and should be collected close to the antenna used to obtain the radiometric observables. Therefore the Antenna FR is regarded as the source of the tropospheric and weather data provided to FRs in the SLS Radiometric Data Production FR Stratum.

4.2.2.1.6 The Antenna provides as output the carrier signal, of which the nominal frequency is specified by the applicable FR of the Physical Channel Stratum.

NOTES

1 In many real TT&C networks, the interface between the transmitter or receiver and the aperture is at Intermediate Frequency (IF) and not at RF as formally represented in the FRM. The nature of such IF interfaces is dependent on local implementation details. Formally modeling the interface as being at RF consolidates the radio-related parameters in one logical place in the FRM. The FRM, being an abstract logical model, does not prescribe or constrain the deployment of functionality to real physical systems.

2 Signal reception FRs in the Physical Channel FR Stratum (e.g., CCSDS 401 Space Link Carrier Reception FR, Delta-DOR Raw Data Collection FR, and/or Open Loop Data Collection FR) may use different sets of RF-related parameters to represent the characteristics of the received carrier signal, tailored to representing those aspects of the received waveform that are relevant to the functions performed by the FR. When multiple signal-reception FRs are configured to process the same received RF carrier signal output by an Antenna FR, the RF-related configuration parameters of all of those Physical Channel FR spectrum FRs are set to values that represent the characteristics of the shared received waveform.

4.2.2.1.7 An Antenna FR may be limited to ‘transmit-only’ or ‘receive-only’. One antenna can be used by multiple forward and/or return space links simultaneously. The Antenna FR also encompasses the tracking receiver used to lock onto the RF signal for the purposes of autotracking.

4.2.2.1.8 There are no CCSDS Recommended Standards that specify the behavior or managed parameters of the resources represented by the Antenna FR.

4.2.2.2 SAPs and Ancillary Interfaces Used by This Functional Resource

4.2.2.2.1 SAPs Accessed by This Functional Resource

None.

4.2.2.2.2 SAPs Hosted by This Functional Resource

4.2.2.2.2.1 The Antenna FR has a Transmit RF Carrier Signal SAP that can be accessed by multiple Accessors (if it is a multi-user antenna).

4.2.2.2.2.2 The Antenna FR has a Received RF Carrier Signal SAP that can be accessed by multiple Accessors.

4.2.2.2.3 Ancillary Interfaces Required by This Functional Resource

None.

4.2.2.2.4 Ancillary Interfaces Provided by This Functional Resource

The Antenna FR provides an Aperture Data ancillary interface. This interface provides pointing angles, STEC, and tropospheric and meteorological measurements (as appropriate to the specific antenna).

5 PHYSICAL CHANNEL FUNCTIONAL RESOURCE STRATUM

5.1 OVERVIEW

The Physical Channel FR Stratum has four FR Sets:

- the CCSDS 401 Physical Channel Transmission FR Set;
- the CCSDS 401 Physical Channel Reception FR Set;
- the Delta-DOR Raw Data Collection FR Set; and
- the Open Loop Data Collection FR Set.

5.2 CCSDS 401 PHYSICAL CHANNEL TRANSMISSION FUNCTIONAL RESOURCE SET OF THE PHYSICAL CHANNEL ABSTRACT STRATUM

5.2.1 OVERVIEW

The CCSDS 401 Physical Channel Transmission FR Set of the Physical Channel Stratum comprises the following FR Types:

- a) CCSDS 401 Space Link Carrier Transmission; and
- b) Ranging Transmission.

Figure 5-1 illustrates the FR Types that constitute the CCSDS 401 Physical Channel Transmission FR Set.

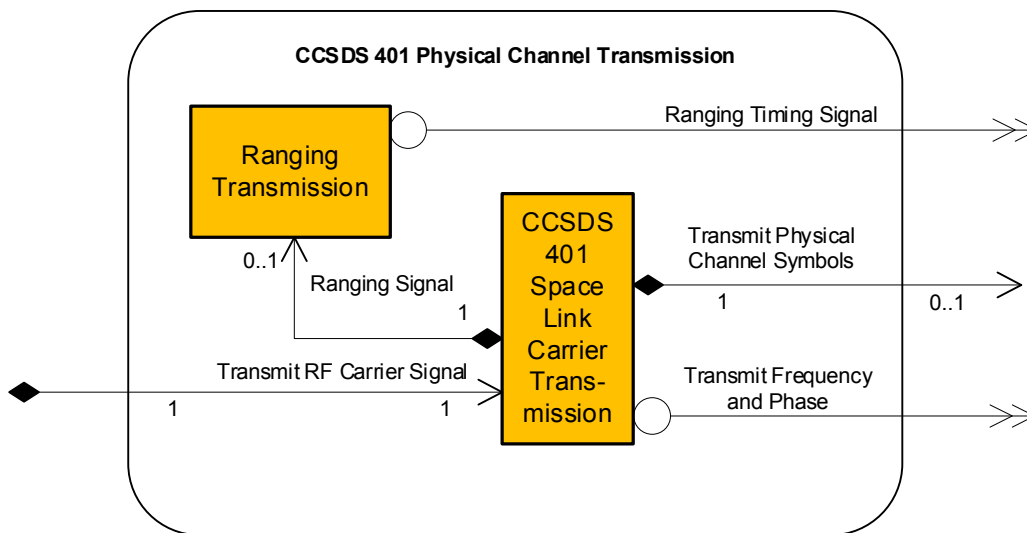

Figure 5-1: Member Functional Resources of the CCSDS 401 Physical Channel Transmission Functional Resource Set

5.2.2 CCSDS 401 SPACE LINK CARRIER TRANSMISSION

5.2.2.1 General

5.2.2.1.1 The FR classifier of the CCSDS 401 Space Link Carrier Transmission FR Type is `Ccsds401SpaceLinkCarrierXmit`.

5.2.2.1.2 The CCSDS 401 Space Link Carrier Transmission FR accepts as input the optionally convolutionally encoded physical channel symbol stream from an FR in the Synchronization and Channel Coding FR Stratum. It also accepts from the Ranging Transmission FR the ranging signal for modulation of the carrier. The CCSDS 401 Space Link Carrier Transmission FR provides the resultant modulated RF carrier signal to an FR in the Aperture FR Stratum and the actual carrier frequency and phase to one or more FRs in the SLS Radiometric Data Production FR Stratum.

NOTE – In many real TT&C networks, the interface between the transmitter and the aperture is at IF and not at RF as formally represented in the FRM. The nature of such IF interfaces is dependent on local implementation details. Formally modeling the interface as being at RF consolidates the radio-related parameters in one logical place in the FRM. The FRM, being an abstract logical model, does not prescribe or constrain the deployment of functionality to real physical systems.

5.2.2.1.3 The CCSDS 401 Space Link Carrier Transmission FR corresponds to the radio frequency modulation and transmission functions, as specified in *Radio Frequency and Modulation Systems: Part 1—Earth Stations and Spacecraft* (reference [23]). That Recommended Standard does not explicitly specify the managed parameters of the functions specified therein.

5.2.2.2 SAPs and Ancillary Interfaces Used by This Functional Resource

5.2.2.2.1 SAPs Accessed by This Functional Resource

The CCSDS 401 Space Link Carrier Transmission FR accesses a Transmit RF Carrier Signal SAP that can be accessed by multiple Accessors (if it is a multi-user antenna).

5.2.2.2.2 SAPs Hosted by This Functional Resource

5.2.2.2.2.1 The CCSDS 401 Space Link Carrier Transmission FR has a Transmit Physical Channel Symbols SAP that is accessed by zero or one Accessor.

NOTE – When the space link is used only for ranging, there is no Accessor for the Transmit Physical Channel Symbols SAP.

5.2.2.2.2.2 The CCSDS 401 Space Link Carrier Transmission FR has a Ranging Signal SAP that is accessed by zero or one Ranging Transmission FR.

NOTE – When the space link is used only for data transmission, there is no Accessor for the Ranging Signal SAP.

5.2.2.2.3 Ancillary Interfaces Required by This Functional Resource

None.

5.2.2.2.4 Ancillary Interfaces Provided by This Functional Resource

The CCSDS 401 Space Link Carrier Transmission FR provides a Transmit Frequency and Phase ancillary interface.

5.2.3 RANGING TRANSMISSION

5.2.3.1 General

5.2.3.1.1 The FR classifier of the Ranging Transmission FR Type is `RngXmit`.

5.2.3.1.2 The Ranging Transmission FR provides the ranging signal to be radiated to the spacecraft to the CCSDS 401 Space Link Carrier Transmission for modulation onto the forward carrier. It provides the timing information needed by the Range and Doppler Extraction FR of the CCSDS 401 Physical Channel Reception FR Set.

5.2.3.1.3 There are no CCSDS, European Cooperation for Space Standardization (ECSS), or Deep Space Network (DSN) standards that specify the managed parameters of the resources represented by the Ranging Transmission FR.

5.2.3.1.4 The Ranging Transmission FR generates the ranging signal that is applied to the forward physical channel. Depending on the ranging technology used, the ranging signal takes the form of:

- a) ranging tones as defined in the ECSS Ranging and Doppler tracking standard (reference [20]) and the DSN sequential ranging standard (reference [21]); or
- b) a Pseudo-Noise (PN) sequence as defined in CCSDS 414.1 (reference [24]).

5.2.3.1.5 The time of radiation of the ranging signal is provided to the Range and Doppler Extraction FR so that on reception of the ranging signal replica, the round-trip delay can be determined.

5.2.3.2 SAPs and Ancillary Interfaces Used by This Functional Resource

5.2.3.2.1 SAPs Accessed by This Functional Resource

The Ranging Transmission FR accesses a Ranging Signal SAP.

5.2.3.2.2 SAPs Hosted by This Functional Resource

None.

5.2.3.2.3 Ancillary Interfaces Required by This Functional Resource

None.

5.2.3.2.4 Ancillary Interfaces Provided by This Functional Resource

The Ranging Transmission FR provides a Ranging Timing Signal ancillary interface.

5.3 CCSDS 401 PHYSICAL CHANNEL RECEPTION FUNCTIONAL RESOURCE SET OF THE RETURN PHYSICAL CHANNEL RECEPTION FUNCTIONAL RESOURCE STRATUM

5.3.1 OVERVIEW

The CCSDS 401 Physical Channel Reception FR Set of the Physical Channel Reception FR Stratum consists of the following FR Types:

- a) CCSDS 401 Space Link Carrier Reception; and
- b) Range and Doppler Extraction.

Figure 5-2 illustrates the internal composition of the CCSDS 401 Physical Channel Reception FR Set.

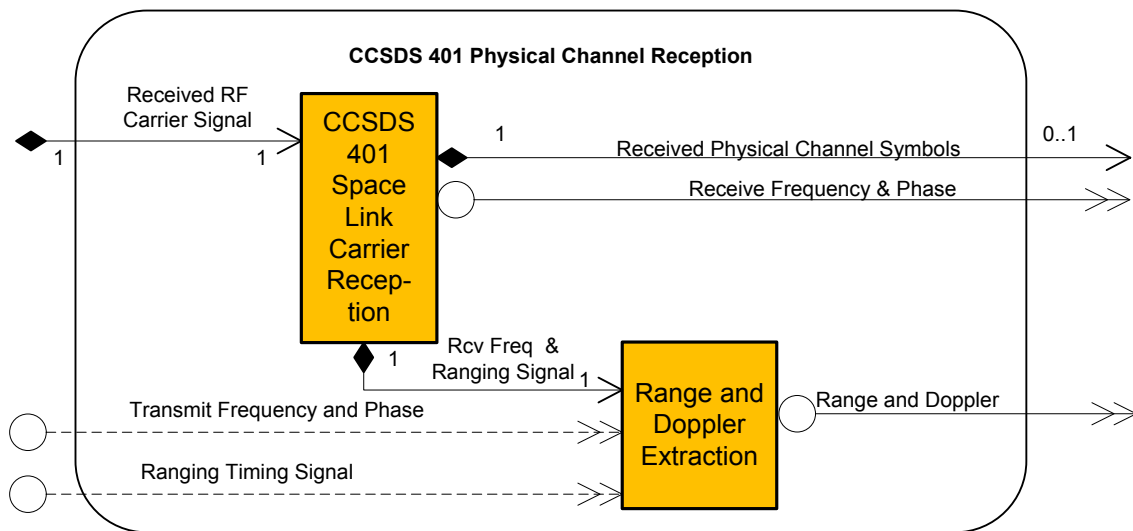

Figure 5-2: Member Functional Resources of the CCSDS 401 Physical Channel Reception Functional Resource Set

5.3.2 CCSDS 401 SPACE LINK CARRIER RECEPTION

5.3.2.1 General

5.3.2.1.1 The FR classifier of the CCSDS 401 Space Link Carrier Reception FR Type is `Ccsds401SpaceLinkCarrierRcpt`.

5.3.2.1.2 The CCSDS 401 Space Link Carrier Reception FR accepts as input the RF carrier signal from an FR in the Aperture FR Stratum. It provides the symbol stream demodulated from the carrier channel to an FR in the Synchronization and Channel Coding FR Stratum. It provides observables needed for the creation of radiometric data to the Range and Doppler Extraction FR.

NOTES

- 1 In many real networks, the interface between the receiver and the aperture is at IF and not at RF as formally represented in the FRM. The nature of such IF interfaces is dependent on local implementation details. Formally modeling the interface as being at RF consolidates the radio-related parameters in one logical place in the FRM. The FRM, being an abstract logical model, does not prescribe or constrain the deployment of functionality to real physical systems.
- 2 If the frequency of the carrier received by the CCSDS 401 Space Link Carrier Reception FR is to be coherently related to the transmitted frequency of an instance of the CCSDS 401 Space Link Carrier Transmission FR that is performed within the same ESLT, the identity of the coherently paired CCSDS 401 Space Link Carrier Transmission FR is indirectly indicated by the value of the CCSDS 401 Space Link Carrier Reception FR `ccsds401CarrierRcptTransponderRatio` parameter, as defined in the SANA Functional Resources registry.
- 3 If the frequency of the carrier received by the CCSDS 401 Space Link Carrier Reception FR is to be coherently related to the transmitted frequency of an instance of the CCSDS 401 Space Link Carrier Transmission FR that is performed by a different ESLT, the transmit frequency will have to be conveyed from that transmitting ESLT by some mechanism. Such a mechanism could be an instance of TD-CSTS, in which the transmitting ESLT serves as the provider of the TD-CSTS instance and the receiving ESLT is the TD-CSTS user. The TD-CSTS instance metadata should include the identification of the transmit frequency band, and thus the transponder ratio could be used to identify/confirm the coherently related transmitter. However, there is currently no standard configuration (or FR definition) for a `TdCstsUser` FR.

5.3.2.1.3 The CCSDS 401 Space Link Carrier Reception FR demodulates one stream of return physical channel symbols and/or extracts ranging and/or Doppler data from a return modulated electromagnetic waveform.

5.3.2.1.4 The CCSDS 401 Space Link Carrier Reception FR corresponds to the radio frequency reception and demodulation functions, as specified in *Radio Frequency and Modulation Systems—Part 1: Earth Stations and Spacecraft* (reference [23]). That Recommended Standard does not explicitly specify the managed parameters of the functions specified therein.

NOTE – Although CCSDS 401.0 theoretically permits separate data streams to be modulated on the I and Q channels when Quadrature Phase Shift Keying (QPSK) modulation is used, no existing Provider CSSS supports such a capability, and none are expected to do so. So the CCSDS 401 Space Link Carrier Reception FR as documented in the SANA Functional Resources registry only represents systems that produce a single data stream.

5.3.2.2 SAPs and Ancillary Interfaces Used by This Functional Resource

5.3.2.2.1 SAPs Accessed by This Functional Resource

The CCSDS 401 Space Link Carrier Reception FR accesses the Received RF Carrier Signal SAP.

5.3.2.2.2 SAPs Hosted by This Functional Resource

5.3.2.2.2.1 The CCSDS 401 Space Link Carrier Reception FR has a Received Physical Channel Symbols SAP that can be accessed by zero or more Accessors.

NOTE – When the space link is used only for ranging, there is no Accessor for the Received Physical Channel Symbols SAP.

5.3.2.2.2.2 The CCSDS 401 Space Link Carrier Reception FR has a Receive Frequency and Ranging Signal SAP that is accessed by zero or one Range and Doppler Extraction FR.

NOTE – When the space link is used only for data reception, there is no Accessor for the Range and Doppler Extraction SAP.

5.3.2.2.3 Ancillary Interfaces Required by This Functional Resource

None.

5.3.2.2.4 Ancillary Interfaces Provided by This Functional Resource

The CCSDS 401 Space Link Carrier Reception FR provides a Receive Frequency and Phase ancillary interface.

5.3.3 RANGE AND DOPPLER EXTRACTION

5.3.3.1 Overview

The FR classifier for the Range and Doppler Extraction FR Type is `RngAndDopplerExtraction`.

The Range and Doppler Extraction FR accepts as input the timing information from the Ranging Transmission FR of the CCSDS 401 Physical Channel Reception Transmission FR Set and the range and Doppler data from the CCSDS 401 Space Link Carrier Reception FR. It provides range and Doppler observables to one or more FRs in the SLS Radiometric Data Production FR Stratum.

There are no CCSDS, ECSS, or DSN standards that specify the managed parameters of the resources represented by the Range and Doppler Extraction FR.

The Range and Doppler Extraction FR extracts the ranging signal that is applied to the forward physical channel by the Ranging Transmission FR. Depending on the ranging technology used, the ranging signal takes the form of:

- a) ranging tones as defined in the ECSS Ranging and Doppler Tracking standard (reference [20]) and the DSN Sequential Ranging standard (reference [21]); or
- b) a PN sequence as defined in CCSDS 414.1 (reference [24]).

The time of radiation of the ranging signal is provided by the Ranging Transmission FR so that on reception of the ranging signal replica, the round-trip delay can be determined.

5.3.3.2 SAPs and Ancillary Interfaces Used by This Functional Resource

5.3.3.2.1 SAPs Accessed by This Functional Resource

The Range and Doppler Extraction FR accesses a Receive Frequency and Ranging Signal SAP.

5.3.3.2.2 SAPs Hosted by This Functional Resource

None.

5.3.3.2.3 Ancillary Interfaces Required by This Functional Resource

5.3.3.2.3.1 The Range and Doppler Extraction FR optionally requires a Ranging Timing Signal ancillary interface.

5.3.3.2.3.2 The Range and Doppler Extraction FR optionally requires a Transmit Frequency and Phase ancillary interface.

5.3.3.2.4 Ancillary Interfaces Provided by This Functional Resource

The Range and Doppler Extraction FR provides a Range and Doppler ancillary interface.

5.4 DELTA-DOR RAW DATA COLLECTION FUNCTIONAL RESOURCE SET OF THE PHYSICAL CHANNEL FUNCTIONAL RESOURCE STRATUM

5.4.1 OVERVIEW

The Delta-DOR Data Collection FR Set of the Physical Channel consists of the Delta-DOR Raw Data Collection FR. Figure 5-3 illustrates the member FR of the Delta-DOR Raw Data Collection FR Set.

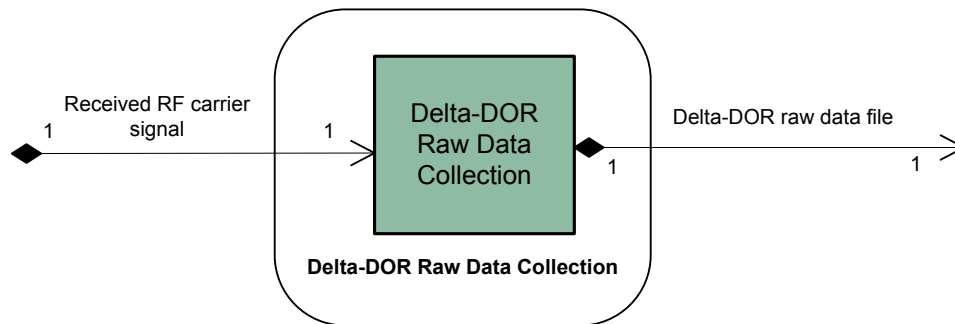

Figure 5-3: Member Functional Resource of the Delta-DOR Raw Data Collection Functional Resource Set

5.4.2 DELTA-DOR RAW DATA COLLECTION

5.4.2.1 The FR classifier of the Delta-DOR Raw Data Collection FR Type is `DdorRawDataCollection`.

5.4.2.2 Delta-DOR Raw Data Collection functions consist of (a) the reception of the RF signal by the Delta DOR open-loop receiver when tracking a spacecraft or a quasar, and (b) the collection of the Delta-DOR raw data samples and organization of them in the standard Delta-DOR Raw Data file format in accordance with *Delta-DOR Raw Data Exchange Format* (reference [31]) for storage.

5.4.2.3 The parameters of this FR provide the data necessary for the generation of the CCSDS 506.1-B-1 formatted files, which implicitly also specify the configuration of the open-loop receiver used for the collection of the raw Delta-DOR data.

5.4.2.4 SAPs and Ancillary Interfaces Used by This Functional Resource

5.4.2.4.1 SAPs Accessed by This Functional Resource

The Delta-DOR Raw Data Collection FR accesses the Received RF Carrier Signal SAP.

5.4.2.4.2 SAPs Hosted by This Functional Resource

The Delta-DOR Raw Data Collection FR has a Delta-DOR Raw Data File SAP that is accessed by one instance of the DdorRawDataStore FR.

5.4.2.4.3 Ancillary Interfaces Required by This Functional Resource

None.

5.4.2.4.4 Ancillary Interfaces Provided by This Functional Resource

None.

5.5 OPEN LOOP DATA COLLECTION FUNCTIONAL RESOURCE SET OF THE PHYSICAL CHANNEL FUNCTIONAL RESOURCE STRATUM

5.5.1 OVERVIEW

The Open Loop Data Collection FR Set of the Physical Channel FR Stratum consists of the Open Loop Data Collection FR. Figure 5-4 illustrates the member FRs of the Open Loop Data Collection FR Set.

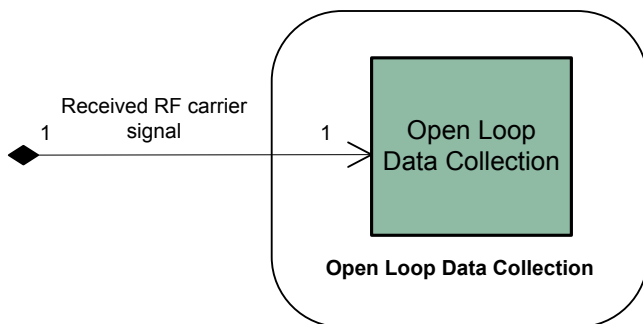

Figure 5-4: Member Functional Resources of the Open Loop Data Collection Functional Resource Set

5.5.2 OPEN LOOP DATA COLLECTION

5.5.2.1 Overview

The FR classifier of the Open Loop Data Collection FR Type is `OpenLoopDataCollection`.

Open Loop Data Collection functions consist of (a) the reception of the RF carrier signal by the open-loop receiver when tracking a spacecraft and (b) the collection of open loop data samples into provider-specific open loop data files.

The Open Loop Data Collection FR can be configured to record complex (in-phase and quadrature-phase) samples of the received carrier signal. Several channels, each centered on a different frequency, can be recorded concurrently. The sampling rate and the sample size are configurable. This functionality is not used in routine operations, but for diagnostic purposes or specific engineering tasks. The capabilities of the open-loop receivers vary depending on the agency-specific equipment. Also, the format in which the recorded data are made available is not standardized. Agencies will have invested in the development of analysis tools for the proprietary file format. Therefore this FR specifies neither a specific file format nor a file naming convention. Also, methods of storage of the open loop data files and transfer of such files are agency-specific matters and outside the scope of the FR standardization.

5.5.2.2 SAPs and Ancillary Interfaces Used by This Functional Resource

5.5.2.2.1 SAPs Accessed by This Functional Resource

The Open Loop Data Collection FR accesses the Received RF Carrier Signal SAP.

5.5.2.2.2 SAPs Hosted by This Functional Resource

None.

5.5.2.2.3 Ancillary Interfaces Required by This Functional Resource

None.

5.5.2.2.4 Ancillary Interfaces Provided by This Functional Resource

None.

6 SYNCHRONIZATION AND CHANNEL CODING FUNCTIONAL RESOURCE STRATUM

6.1 OVERVIEW

This section identifies and defines the FR Sets of the Synchronization and Channel Coding FR Stratum.

The Synchronization and Channel Coding FR Stratum has three FR Sets:

- the TC Synchronization and Channel Encoding FR Set;
- the TM Synchronization and Channel Encoding FR Set; and
- the TM Synchronization and Channel Decoding FR Set.

6.2 TC SYNCHRONIZATION AND CHANNEL ENCODING FUNCTIONAL RESOURCE SET OF THE SYNCHRONIZATION AND CHANNEL CODING FR STRATUM

6.2.1 OVERVIEW

The TC Synchronization and Channel Encoding FR Set of the Synchronization and Channel Coding FR Stratum consists of the TC PLOP, Synchronization, and Channel Encoding FR. Figure 6-1 illustrates the FR Type that constitutes the TC Synchronization and Channel Encoding FR Set.

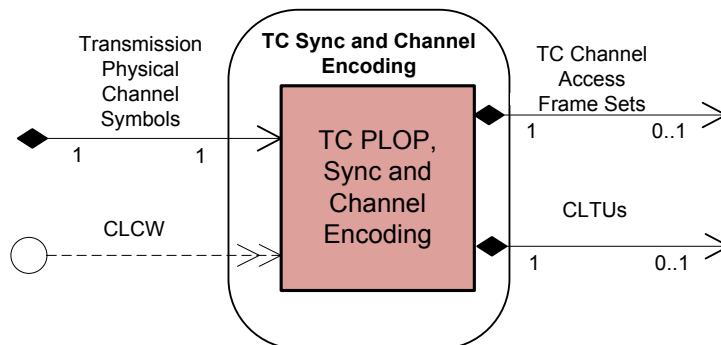

Figure 6-1: Member Functional Resource of the TC Synchronization and Channel Encoding Functional Resource Set

6.2.2 TC PLOP, SYNCHRONIZATION, AND CHANNEL ENCODING FR

6.2.2.1 Overview

The FR classifier of the TC PLOP, Synchronization, and Channel Encoding FR Type is `TcPlopSyncAndChnlEncode`.

The TC PLOP, Synchronization, and Channel Encoding FR corresponds to the following functions:

- a) the Random Sequence Generation function of the *TC Synchronization and Channel Coding* Recommended Standard (references [5] and [11]);
- b) the Bose–Chaudhuri–Hocquenghem (BCH) Encoding function of the *TC Synchronization and Channel Coding* Recommended Standard;
- c) the LDPC Encoding function of the *TC Synchronization and Channel Coding* Recommended Standard;
- d) the CLTU Generation functions of the *TC Synchronization and Channel Coding* Recommended Standard;
- e) the PLOP of the *TC Synchronization and Channel Coding* Recommended Standard;
- f) the emission of ‘data unit processing complete’ CSTS event notifications, as required by the CSTS Data Processing procedure, Buffered Data Processing procedure, or Sequence Controlled Data Processing procedure (4.6.3.4 of reference [4]); and
- g) the discarding of all data units with specified `service-instance-id` upon receipt of a CSTS ‘discard all data units’ request, as required by the CSTS Data Processing procedure, Buffered Data Processing procedure, or Sequence Controlled Data Processing procedure (4.6.3.4 of reference [4]).

The TC PLOP, Synchronization, and Channel Encoding FR supports implementations of issues 3 and above of the *TC Synchronization and Channel Coding* Recommended Standard. Implementations conforming to issue 3 (reference [5]) perform the Random Sequence Generation ((a), above) before LDPC encoding ((c), above). Implementations conforming to issue 4 (reference [11]) and above (if any) perform LDPC encoding before Random Sequence Generation. The determination of which variant is applicable to a given mission is documented in agreements between the service provider and the user mission and is selected in individual Service Packages through the setting of the `frame: encodeType: ldpcEncoding: randomizationCodingSequence` component of the `tcPlopSyncInputDataFormat` configuration parameter.

Section 8 of the *TC Synchronization and Channel Coding* Recommended Standard (reference [5]) specifies the set of managed parameters that are pertinent to the functions specified in that Recommended Standard. All managed parameters from that Recommended Standard are reflected in the configuration parameters of the TC PLOP, Synchronization, and

Channel Encoding FR as defined in the SANA Functional Resources registry, **except for the Decoding Mode managed parameter**, which applies only to the receiving end.

NOTE – The configuration parameters of the TC PLOP, Synchronization, and Channel Encoding FR also include parameters that are not explicitly identified as managed parameters in the Recommended Standard.

An instance of the TC PLOP, Synchronization, and Channel Encoding FR is configured to process either TC channel access frame sets (groups of transfer frames) or CLTUs.

When configured to support TC channel access frame sets, the FR performs: Random Sequence Generation ((a) above—optional for BCH, mandatory for LDPC), either BCH Encoding ((b) above) or LDPC Encoding ((c) above), the CLTU Generation ((d) above), and the PLOP ((e) above). When configured to process CLTUs, the FR performs only the PLOP ((e) above).

Figure 6-2 illustrates the sublayers of the TC PLOP, Synchronization, and Channel Encoding FR for implementations corresponding to issue 3 (CCSDS 231.0-B-3, reference [5]).

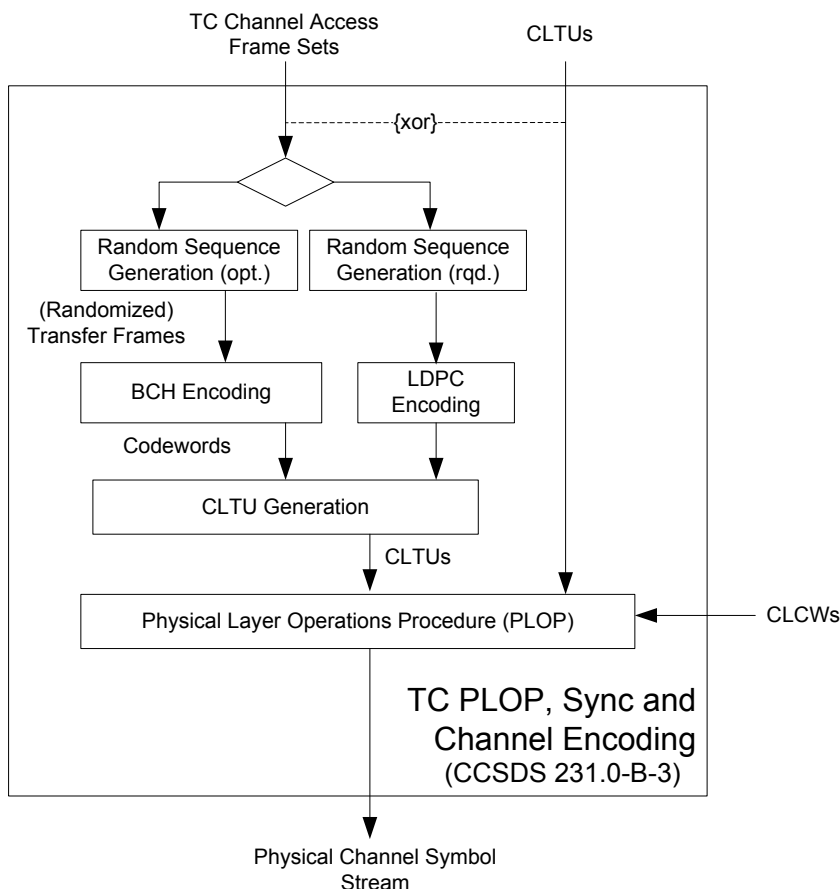

Figure 6-2: Internal Structure of the TC PLOP, Synchronization, and Channel Encoding Functional Resource Corresponding to CCSDS 231.0-B-3

Figure 6-3 illustrates the sublayers of the TC PLOP, Synchronization, and Channel Encoding FR for implementations corresponding to issue 4 (CCSDS 231.0-B-4, reference [11]) and above (if any).

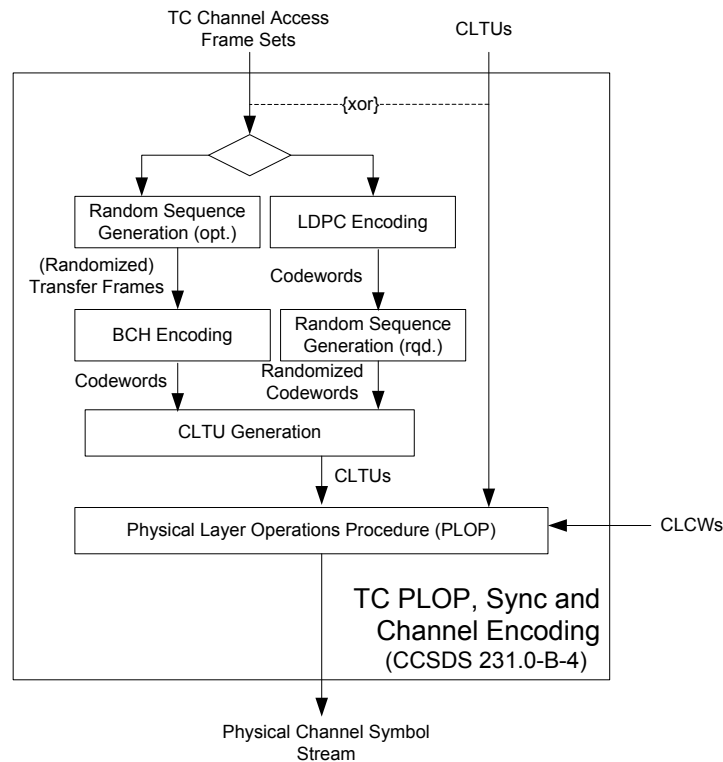

Figure 6-3: Internal Structure of the TC PLOP, Synchronization, and Channel Encoding Functional Resource Corresponding to CCSDS 231.0-B-4

6.2.2.2 Systematic Retransmission and Multiple Transfer Frames per CLTU

The *TC Synchronization and Channel Coding* Recommended Standard (reference [5]) specifies a mechanism for the systematic retransmission of CLTUs. As formally specified in reference [5], the TC Synchronization and Channel Coding sublayer provides a Channel Access service interface through which the SDLP above it submits a set of frames, optionally accompanied by a `Repetitions` parameter. The set of frames, referred to as a *TC channel access frame set* in this Recommended Practice (see NOTE 1 below), constitutes the set of frames from which the TC Sync and Channel Coding sublayer forms the CLTU. If the `Repetitions` parameter has a value greater than one, then the TC Sync and Channel Coding sublayer transmits that CLTU `Repetitions` number of times.

The TC PLOP, Synchronization, and Channel Encoding FR performs the systematic retransmission function as specified in the *TC Synchronization and Channel Coding* Recommended Standard, with the constraint that systematic retransmission is performed only when the TC channel access frame sets each contain a single transfer frame. If multiple frames are present in a TC channel access frame set, the resultant CLTU is transmitted only once.

The `tcPlopSyncInputDataFormat: frame: maxCltuRepetitionsMaxFramesPerCltu` configuration parameter has two *choices*: (a) the `maxNumberOfFramesPerCltu` choice is used to specify that multiple-frame CLTUs is supported by the FR instance, and (b) the `maxNumberOfCltuRepetitions` choice is used to specify that repeated transmission of multiple single-frame CLTUs is supported by the FR instance. If the `maxNumberOfFramesPerCltu` choice is used, the presence and/or value of the `Repetitions` parameter is ignored and each CLTU is transmitted only once, regardless of the number of frames within the TC channel access frame set.

NOTES

- 1 The term *TC channel access frame set* is not formally defined in any CCSDS Recommended Standard. The *TC Synchronization and Channel Coding* Recommended Standard does, however, define the `ChannelAccess.request` service primitive as the mechanism by which the TC coding sublayer receives a ‘data unit’ of TC frames that is optionally accompanied by a `Repetitions` parameter. Each data unit of frames is transformed into a single CLTU, and the `Repetitions` parameter specifies how many times the resulting CLTU is to be transmitted. This Recommended Practice uses the term *TC channel access frame set* to refer to the data unit of frames of the `ChannelAccess.request` service primitive. It is important to note that a TC channel access frame set is not to be confused with a TM Sync and Channel Coding CADU. Whereas the TC channel access frame set exists at the interface between the space link protocol and coding sublayer, the TM CADU exists at the interface between the coding sublayer and Physical Layer.
- 2 The specification of the SLE Forward CLTU service (reference [27]) does not use the `Repetitions` parameter to implement systematic retransmission. In the case of Forward CLTU service, it is the responsibility of the service user to transfer the same CLTU multiple times to cause that CLTU to be repeated across the space link.

6.2.2.3 Regulation of the Resource Status by Bit Lock and RF Availability Status of the Forward Space Link

The resource status of the TC PLOP, Synchronization, and Channel Encoding FR can be made to depend upon the bit lock and/or RF availability status of a corresponding forward space link through the `tcPlopSyncClcwEvaluation` configuration parameter. If either of these indicators is configured to be required, then the CLCW ancillary interface is required. When the CLCW ancillary interface is used, the resource status of the FR instance transitions between ‘operational’ and ‘interrupted’ depending on the `No Bit Lock` and/or `No RF Available` flags of the CLCWs received through that interface, as defined in table 6-1.

NOTE – The dependency on the CLCW flags only affects the resource status when the FR instance would otherwise be ‘operational’. The CLCW flags have no effect when the resource status is either ‘configured’ or ‘halted’.

Table 6-1: Resource Status as a Function of Space Link Availability and Bit Lock

tcPlopSyncClwEvaluation Configuration Parameter Settings	CLCW Flag Settings			
	No Bit Lock = true	No Bit Lock = false	No RF Available = true	No RF Available = false
noEvaluation	operational	operational	operational	operational
evaluation: linkCondition = noEvaluation	operational	operational	operational	operational
evaluation: linkCondition = rfAvailableVerified	operational	operational	interrupted	operational
evaluation: linkCondition = bitLockVerified	interrupted	operational	operational	operational
evaluation: linkCondition = rfAvailableAndBitLockVerified	interrupted	operational	interrupted	operational

6.2.2.4 SAPs and Ancillary Interfaces Used by This Functional Resource

6.2.2.4.1 SAPs Accessed by This Functional Resource

The TC PLOP, Synchronization, and Channel Encoding FR accesses the Transmission Physical Channel Symbols SAP.

6.2.2.4.2 SAPs Hosted by This Functional Resource

6.2.2.4.2.1 The TC PLOP, Synchronization, and Channel Encoding FR has a TC Channel Access Frame Set SAP that can be accessed by a single Accessor.

6.2.2.4.2.2 The TC PLOP, Synchronization, and Channel Encoding FR has a CLTU SAP that can be accessed by a single Accessor.

6.2.2.4.3 Ancillary Interfaces Required by This Functional Resource

The TC PLOP, Synchronization, and Channel Encoding FR requires a CLCW ancillary interface when the resource status of the FR instance is configured to be regulated by the No Bit Lock and/or No RF Available flags of the CLCW.

6.2.2.4.4 Ancillary Interfaces Provided by This Functional Resource

None.

6.3 TM SYNCHRONIZATION AND CHANNEL ENCODING FUNCTIONAL RESOURCE SET OF THE SYNCHRONIZATION AND CHANNEL CODING FR STRATUM

6.3.1 OVERVIEW

The TM Synchronization and Channel Encoding FR Set of the Synchronization and Channel Coding FR Stratum consists of the TM Synchronization and Channel Encoding FR.

Figure 6-4 illustrates the FR Type that constitutes the TM Synchronization and Channel Encoding FR Set.

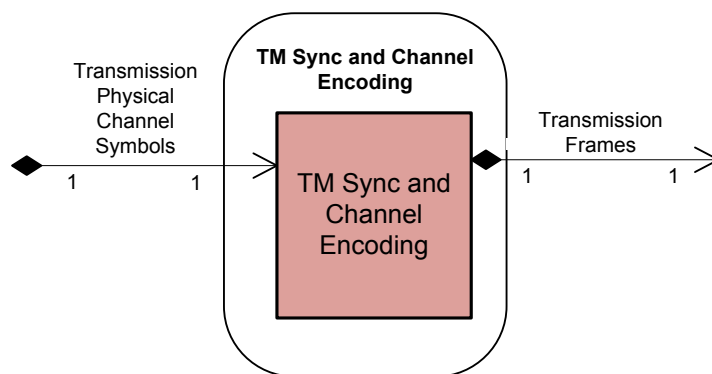

Figure 6-4: Member Functional Resource of the TM Synchronization and Channel Encoding Functional Resource Set

6.3.2 TM SYNCHRONIZATION AND CHANNEL ENCODING FR

6.3.2.1 Overview

The FR classifier of the TM Synchronization and Channel Encoding FR Type is `TmSyncAndChnlEncode`.

The TM Synchronization and Channel Encoding FR is used to support SDLPs that use fixed-length frames on the transmitted link. As of this issue of this Recommended Practice, there are two CCSDS SDLPs that use fixed-length frames on the transmission link, AOS (reference [18]) and USLP (reference [34]).

The TM Synchronization and Channel Encoding FR corresponds to the following functions:

- a) the Reed-Solomon Encoding function specified in the *TM Synchronization and Channel Coding* Recommended Standard (reference [6]);
- b) the (transfer frame) LDPC Encoding function specified in the *TM Synchronization and Channel Coding* Recommended Standard;

- c) the Pseudo-Random Sequence Generation function specified in the *TM Synchronization and Channel Coding* Recommended Standard;
- d) the Attachment of Sync Markers function specified in the *TM Synchronization and Channel Coding* Recommended Standard;
- e) the Convolutional Encoding function specified in the *TM Synchronization and Channel Coding* Recommended Standard;
- f) the (sync-marked transfer frame) LDPC Encoding function specified in the *TM Synchronization and Channel Coding* Recommended Standard;
- g) the emission of ‘data unit processing completed’ CSTS event notifications, as required by the CSTS Data Processing procedure, Buffered Data Processing procedure, or Sequence Controlled Data Processing procedure (4.6.7.4 of reference [4]); and
- h) the discarding of all data units with specified `service-instance-id` upon receipt of a CSTS ‘discard all data units’ request, as required by the CSTS Data Processing procedure, Buffered Data Processing procedure, or Sequence Controlled Data Processing procedure (4.6.7.3 of reference [4]).

Section 12 of the *TM Synchronization and Channel Coding* Recommended Standard (reference [6]) specifies a set of managed parameters. All managed parameters from that Recommended Standard for the functions implemented by the FR are reflected in the configuration parameters of the TM Synchronization and Channel Encoding FR as defined in the SANA Functional Resources registry.

NOTES

- 1 The *TM Synchronization and Channel Coding* Recommended Standard has multiple scalar configuration parameters, many of which are applicable to only one of the available encoding schemes and are therefore ‘not applicable’ when any other coding scheme is used. The TM Synchronization and Channel Encoding FR uses the complex-structured configuration parameter `TmSyncEncCodingSelection` to represent the configuration parameters of the supported coding schemes in such a way that only the applicable parameter values for the selected coding scheme are specified.
- 2 The *TM Synchronization and Channel Coding* Recommended Standard managed parameter *Transfer Frame Length* is represented by the TM Synchronization and Channel Encoding FR configuration parameter `TmSyncFrameLength`.
- 3 The configuration parameters of the TM Synchronization and Channel Encoding FR also include parameters that are not explicitly identified as managed parameters in the *TM Synchronization and Channel Coding* Recommended Standard.

Figure 6-5 illustrates the component functions of the TM Synchronization and Channel Encoding FR.

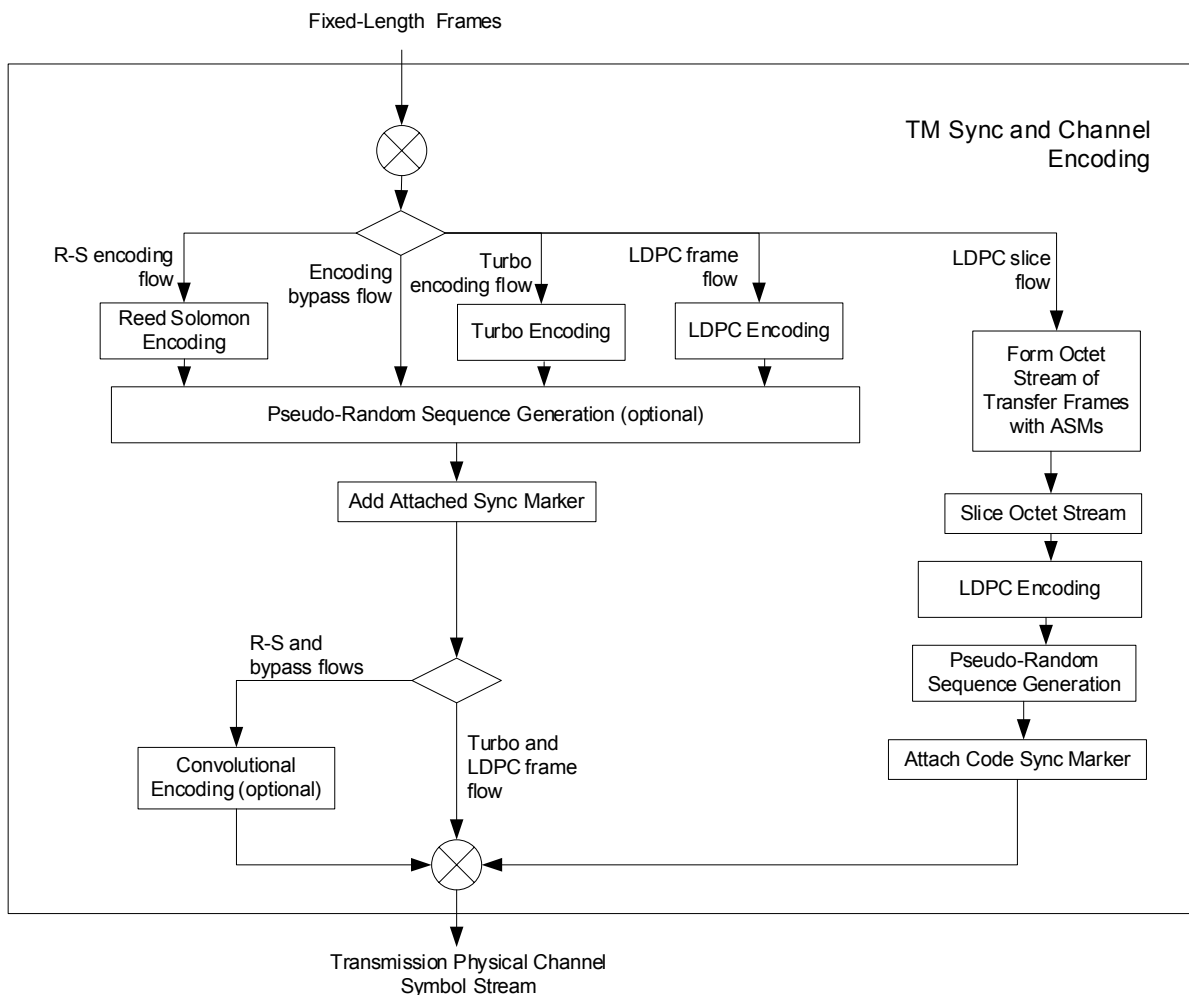

Figure 6-5: Internal Structure of the TM Synchronization and Channel Encoding Functional Resource

6.3.2.2 Encoding and Channel Synchronization Flows

6.3.2.2.1 Flow Types. There are five possible flows through the functions of the Forward TM Synchronization and Channel Encoding FR, each of which constitutes a set of encoding functions. The following subsections describe the remaining functions that constitute each flow.

NOTE – The frames do not necessarily conform to the CCSDS AOS or USLP Transfer Frame specifications; they can be any data units conforming to some fixed-length-frame SDLP format. The generation of Only Idle Data Frames (if any) in accordance with the respective SDLP is performed by FRs specifically suited to such an SDLP (i.e., protocol-specific MC Mux FRs).

6.3.2.2.2 Encoding Bypass Flow. This flow is used for frames that do not require Reed-Solomon or LDPC encoding to be performed by the service provider, either because the

frames do not require any encoding or because they have already been encoded by the Mission prior to being transferred to the service provider using CCSDS-standard or Mission-specific encoding techniques. In this flow, the TM Synchronization and Channel Encoding FR optionally pseudo-randomizes each frame, adds the ASM, and optionally convolutionally encodes the resultant CADUs.

6.3.2.2.3 Reed-Solomon Encoding Flow. This flow is used for frames that require CCSDS-standard Reed-Solomon encoding to be performed by the service provider. In this flow, the TM Synchronization and Channel Encoding FR applies Reed-Solomon encoding to each frame, optionally pseudo-randomizes each frame, adds the ASM, and optionally convolutionally encodes the resultant CADUs.

6.3.2.2.4 Turbo Encoding Flow. This flow is used for frames that require CCSDS-standard Turbo encoding to be performed by the service provider. In this flow, the TM Synchronization and Channel Encoding FR applies Turbo encoding to each frame, optionally pseudo-randomizes each frame, and adds the ASM.

6.3.2.2.5 LDPC Frame Flow. This flow is used for frames that require CCSDS-standard LDPC encoding to be performed by the service provider. In this flow, the TM Synchronization and Channel Encoding FR applies LDPC encoding to each frame, optionally pseudo-randomizes each frame, and adds the ASM.

6.3.2.2.6 LDPC Slice Flow. This flow is used for frames that require slicing and LDPC encoding to be performed by the service provider. In this flow, the Forward TM Synchronization and Channel Encoding FR adds the ASM to each frame to form an SMTF. Then the FR performs what is called LDPC coding of a stream of SMTFs in reference [6]: a process of slicing the SMTFs into Information Blocks, LDPC-encoding each of the resultant Information Blocks into an *LDPC codeword*, aggregating a specified number of codewords into an *LDPC codeblock*, pseudo-randomizing each LDPC codeblock, and adding the Sync Code Marker to each LDPC codeblock.

6.3.2.3 SAPs and Ancillary Interfaces Used by This Functional Resource

6.3.2.3.1 SAPs Accessed by This Functional Resource

The TM Synchronization and Channel Encoding FR accesses the Transmission Physical Channel Symbols SAP.

6.3.2.3.2 SAPs Hosted by This Functional Resource

TM Synchronization and Channel Encoding has a Transmission Frame SAP that can be accessed by a single Accessor.

6.3.2.3.3 Ancillary Interfaces Required by This Functional Resource

None.

6.3.2.3.4 Ancillary Interfaces Provided by This Functional Resource

None.

6.4 TM SYNCHRONIZATION AND CHANNEL DECODING FUNCTIONAL RESOURCE SET OF THE SYNCHRONIZATION AND CHANNEL CODING FUNCTIONAL RESOURCE STRATUM

6.4.1 OVERVIEW

The TM Synchronization and Channel Decoding FR Set of the Synchronization and Channel Coding FR Stratum consists of the TM Synchronization and Decoding FR. Figure 6-6 illustrates the FRs of the TM Synchronization and Channel Decoding FR Set.

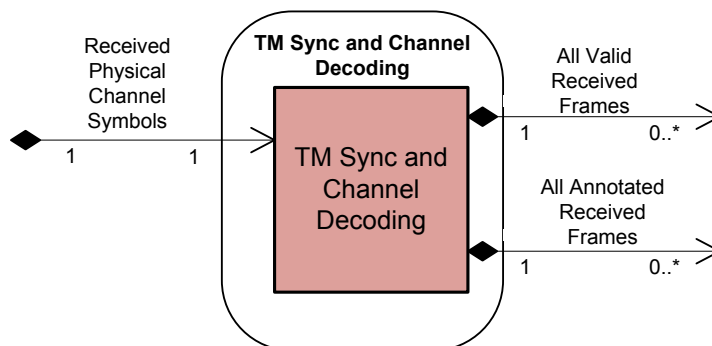

Figure 6-6: Member Functional Resource of the TM Synchronization and Channel Decoding Functional Resource Set

6.4.2 TM SYNCHRONIZATION AND CHANNEL DECODING

6.4.2.1 General

The FR classifier of the TM Synchronization and Channel Decoding FR Type is TmSyncAndChnlDecode.

The TM Synchronization and Decoding FR corresponds to the following functions:

- a) the Convolutional Decoding function specified in the *TM Synchronization and Channel Coding* (reference [6]);
- b) the (SMTF) LDPC Decoding function specified in the *TM Synchronization and Channel Coding Recommended Standard*;

- c) the Frame Synchronization function specified in the *TM Synchronization and Channel Coding* Recommended Standard;
- d) the Pseudo-Random Sequence Removal function specified in the *TM Synchronization and Channel Coding* Recommended Standard;
- e) the (transfer frame) LDPC Decoding function specified in the *TM Synchronization and Channel Coding* Recommended Standard;
- f) the Turbo Decoding function specified in the *TM Synchronization and Channel Coding* Recommended Standard;
- g) the Reed-Solomon Decoding function specified in the *TM Synchronization and Channel Coding* Recommended Standard;
- h) the All Frames Reception function (which performs Frame Error Control decoding) of TM SDLP (reference [19]), AOS SDLP (reference [18]), and USLP (reference [34]); and

NOTE – The All Frames Reception function is formally defined as part of the SDLP. However, its functionality is included in the TM Synchronization and Channel Decoding FR so that the resultant annotated transfer frames reflect all error detection and/or correction performed on those frames.

- i) the Frame Annotation function, which is described in 6.4.2.2.

Section 12 of the *TM Synchronization and Channel Coding* Recommended Standard (reference [6]) specifies a set of managed parameters. All managed parameters from that Recommended Standard are reflected in the configuration parameters of the TM Synchronization and Channel Decoding FR as defined in the SANA Functional Resources registry.

Figure 6-7 illustrates the component functions of the TM Synchronization and Channel Decoding FR.

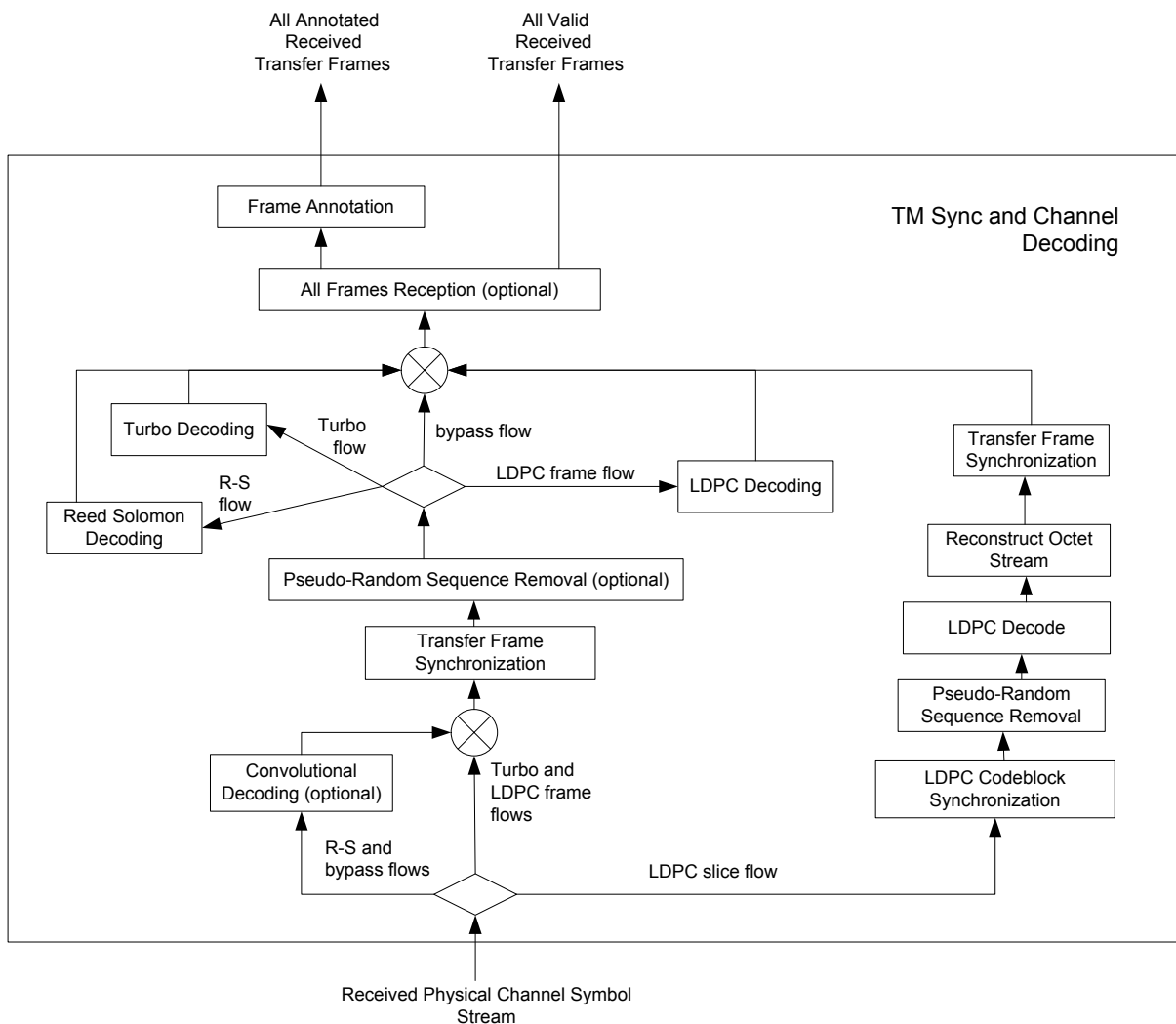

Figure 6-7: Internal Structure of the TM Synchronization and Channel Decoding Functional Resource

NOTE – Although figure 6-6 formally depicts the performance of convolutional decoding before transfer frame synchronization, implementations that perform frame synchronization on the convolutionally encoded symbol stream have been shown to exhibit marginally better frame identification performance. Such implementations are conformant to the pertinent CCSDS Recommended Standards in that the net effect on the processed frames is the same.

6.4.2.2 Frame Annotation Function

The Frame Annotation function annotates each frame with information that is reported as part of the TRANSFER-DATA PDUs of the return SLE Transfer Services (references [2], [3], and [28]). This information is:

- Earth-receive-time of the frame;
- antenna-id of the aperture through which the frame was received;
- data-link-continuity;
- delivered-frame-quality; and
- any private annotation that is optionally bilaterally agreed between the Provider CSSS and the Mission.

6.4.2.3 SAPs and Ancillary Interfaces Used by This Functional Resource

6.4.2.3.1 SAPs Accessed by This Functional Resource

TM Synchronization and Channel Decoding FR accesses the Received Physical Channel Symbols SAP.

6.4.2.3.2 SAPs Hosted by This Functional Resource

6.4.2.3.2.1 The TM Synchronization and Channel Decoding FR has an All Valid Received Frames SAP that can be accessed by multiple Accessors. The All Valid Received Frames SAP carries only those frames that are valid with respect to the decoding schemes configured for the FR instance. The Accessors of this SAP are nominally the return SDLPs, for which only the contents of valid frames are acceptable.

6.4.2.3.2.2 The TM Synchronization and Channel Decoding FR has an All Annotated Received Frames SAP that can be accessed by a multiple Accessors. The All Annotated Received Frames SAP carries both valid and errored frames. The Accessors of this SAP are nominally return transfer services (in particular SLE transfer services) that require the per-data-unit annotation information.

6.4.2.3.3 Ancillary Interfaces Required by This Functional Resource

None.

6.4.2.3.4 Ancillary Interfaces Provided by This Functional Resource

None.

7 SPACE LINK PROTOCOL FUNCTIONAL RESOURCE STRATUM

7.1 OVERVIEW

This section identifies and defines the FR Sets of the Space Link Protocol FR Stratum.

The Space Link Protocol FR Stratum has six FR Sets:

- the TC Space Link Protocol Transmission FR Set;
- the AOS Space Link Protocol Transmission FR Set;
- the VLF Unified Space Data Link Protocol Transmission FR Set;
- the FLF Unified Space Data Link Protocol Transmission FR Set;
- the TM/AOS Space Link Protocol Reception FR Set; and
- the FLF Unified Space Data Link Protocol Reception FR Set.

7.2 TC SPACE LINK PROTOCOL TRANSMISSION FUNCTIONAL RESOURCE SET OF THE SPACE LINK PROTOCOL FUNCTIONAL RESOURCE STRATUM

7.2.1 OVERVIEW

The FR Types that make up the TC Space Link Protocol Transmission FR Set of the Space Link Protocol FR Stratum are:

- a) TC MC Multiplexing; and
- b) TC VC Multiplexing.

Figure 7-1 illustrates the FR Types that constitute the TC Space Link Protocol Transmission FR Set.

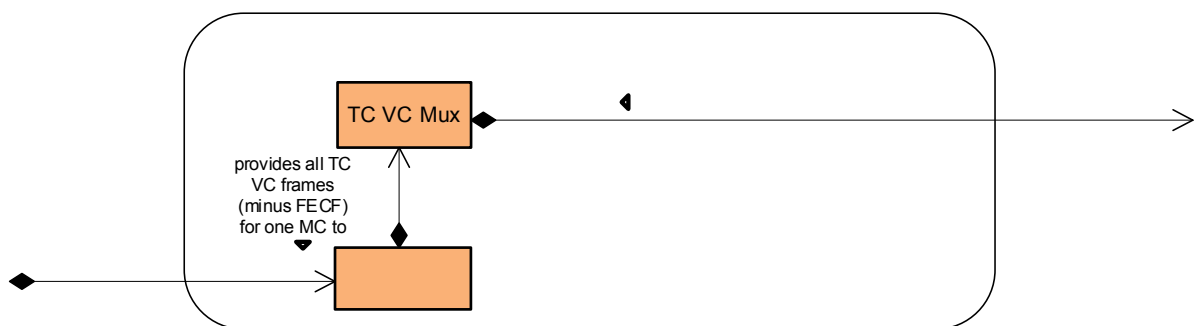

Figure 7-1: Member Functional Resources of the TC Space Link Protocol Transmission Functional Resource Set

NOTE – The TC Space Link Protocol Transmission FR Set may be expanded in the future to include FRs that represent the Virtual Channel Generation (and above) functions of the Sending End of TC SDLP (reference [17]).

7.2.2 TC MC MULTIPLEXING FR

7.2.2.1 General

7.2.2.1.1 The FR classifier of the TC MC Multiplexing FR Type is `TcMcMux`.

7.2.2.1.2 The TC MC Multiplexing FR corresponds to the following functions:

- a) the Master Channel Multiplexing function of TC SDLP (reference [17]), which multiplexes the transfer frames from one or more Master Channels into a single stream of transfer frames; and
- b) the All Frames Generation function of TC SDLP, which optionally adds a Frame Error Control Field (FECF) to the trailer of each frame, groups transfer frames into *TC channel access frame sets* and sends those TC channel access frame sets to the underlying synchronization and coding sublayer one or more times based on the `Repetition` parameters specified for the virtual channels and frame types of the frames contained in those frame sets (see 7.2.2.2).

7.2.2.1.3 The TC MC Multiplexing FR implements the three multiplexing schemes required by the FF-CSTS (reference [32]): absolute priority, polling vector, and First-In-First-Out (FIFO).

NOTE – *TC channel access frame set* is the term used in this Recommended Practice to refer to the groups of TC frames created by the TC SDLP All Frames Generation function. TC SDLP refers to the groups simply as ‘data units’. The *TC Synchronization and Channel Coding* Recommended Standard, however, defines the `ChannelAccess.request` service primitive, through which the coding sublayer receives the groups of frames and associated optional `repetitions` parameters. The term TC channel access frame set is derived from the name of that TC Sync and Channel Coding primitive.

7.2.2.1.4 Table 5-1 of TC SDLP (reference [17]) specifies a set of managed parameters for the Physical Channel. All Physical Channel managed parameters from that Recommended Standard are reflected in the configuration parameters of the TC MC Multiplexing FR as defined in the SANA Functional Resources registry, except for the managed parameters identified in table 7-1.

Table 7-1: PC Managed Parameters of the MC Multiplexing and All Frames Generation Functions of TC SDLP That Are Not in the Configuration Parameters of the TC MC Multiplexing FR

Excluded Recommended Standard Managed Parameter	Comment
Physical Channel Name	The Physical Channel Name is specified in the <code>xxxPhysChnlName</code> parameters of the Physical Channel Stratum FRs. The TC MC Multiplexing FR inherits the value of this parameter from the Physical Channel Stratum FR with which it is associated in the operational configuration.
Transfer Frame Version Number	For Telecommand, this value is fixed to version 1 ('00' binary) and is not configurable.
Valid Spacecraft IDs	The spacecraft IDs of the frames are either set as part of the configuration of FRs that generate frames from user inputs or are included in the validation parameters of FRs that receive frames from user inputs (i.e., the FF-CSTS). Thus the configuration profile as a whole defines the set of valid SCIDs. For this issue of this Recommended Practice, the only source of TC frames is the Forward Frame service, and the valid SCID for each <code>FwdFrameCstsProvider</code> FR instance is specified by its <code>ffAuthorizedGvcidAndBitMask</code> : <code>tcGvcid</code> : <code>tcScid</code> parameter.
Maximum Length of Data Unit Given to the Coding Sublayer	This value is equal to the product of the values of the <code>tcMmuxMaxNumberOfFramesPerCltu</code> and <code>tcMmuxMaxFrameLength</code> parameters.
Maximum Bit Rate Accepted by the Coding Sublayer	This value is derived from the <code>xxxCarrierXmitSymbolRate</code> parameter of the Physical Channel Stratum-level FR and the coding options specified for the TC PLOP, Sync, and Channel Encoding FR instance that is associated with the TC MC Multiplexing FR instance.
Maximum Value for the Repetitions Parameter for the Coding Sublayer	This value is specified by the <code>tcPlopSyncInputDataFormat</code> : <code>frame</code> : <code>maxNumberOfCltuRepetitions</code> configuration parameter of the underlying TC PLOP, Sync, and Channel Encoding FR.

NOTES

- 1 The configuration parameters of the TC MC Multiplexing FR also include parameters that are not explicitly identified as managed parameters in the Recommended Standard.
- 2 Figure 7-2 illustrates the sublayers of the TC MC Multiplexing FR.

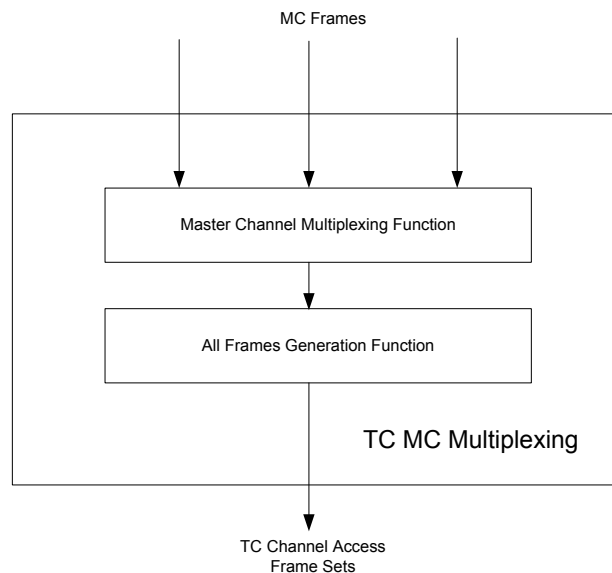

Figure 7-2: Internal Structure of the TC MC Multiplexing Functional Resource

7.2.2.2 Systematic Retransmission and Multiple Transfer Frames per CLTU

7.2.2.2.1 CCSDS Systematic Retransmission

The *TC Synchronization and Channel Coding* Recommended Standard (reference [5]) specifies a mechanism for the systematic retransmission of CLTUs. As specified in reference [5], the TC Synchronization and Channel Coding sublayer provides a Channel Access service interface through which the SDLP above it submits a set of frames, optionally accompanied by a `Repetitions` parameter. The set of frames, referred to as a *TC channel access frame set* in this Recommended Practice (see 6.2.2.2 NOTE 1), constitutes the set of frames from which the TC Sync and Channel Coding sublayer forms the CLTU. TC SDLP (reference [17]) defines managed parameters that specify the values of the `Repetitions` parameter for each VC for frames of two Quality of Service (QoS)/data types: Sequence-Controlled User Data, also called Acceptance check and Data (AD), or Expedited Protocol Control information, also called Bypass of acceptance check and Control (BC). With frames using the Expedited User Data, also called Bypass of acceptance check and Data (BD), QoS/data cannot be systematically retransmitted; that is, they are transmitted only once. If the `Repetitions` parameter has a value greater than one, then the TC Sync and Channel Coding sublayer transmits that CLTU `Repetitions` number of times.

7.2.2.2.2 Systematic Retransmission as Performed by the TC MC Multiplexing Functional Resource

7.2.2.2.2.1 As specified in TC SDLP (reference [17]), the All Frames Generation function generates the TC channel access frame sets and the accompanying `Repetitions` parameter values to form the `ServiceAccess.Request` primitives. This function is performed by the TC MC Multiplexing FR.

7.2.2.2.2.2 As described in 6.2.2.2, the TC PLOP, Sync, and Channel Encoding FR constrains the use of systematic retransmission to CLTUs that each contain a single transfer frame. The constraint is specified through the `tcPlopSyncInputDataFormat: frame: maxCltuRepetitionsMaxFramesPerCltu` configuration parameter, which has two CHOICES: (a) the `maxNumberOfFramesPerCltu` choice is used to specify that multiple-frame CLTUs are supported by the FR instance, and (b) the `maxNumberOfCltuRepetitions` choice is used to specify that repeated transmission of multiple single-frame CLTUs is supported by the FR instance. If the `maxNumberOfFramesPerCltu` choice is used, the presence and/or value of the `Repetitions` parameter is ignored, and each CLTU is transmitted only once, regardless of the number of frames within the TC channel access frame set.

7.2.2.2.2.3 If the `TcPlopSyncInputDataFormat` configuration parameter of the underlying TC PLOP, Sync, and Channel Encoding FR has the `maxNumberOfFramesPerCltu` choice, then the TC MC Multiplexing FR creates TC channel access frame sets, the size of which are constrained by the `tcMcMuxMaxNumberOfFramesPerCltu` configuration parameter. The TC MC Multiplexing FR submits these TC channel access frame sets to the underlying TC PLOP, Sync, and Channel Encoding FR instance with no accompanying `Repetitions` parameter.

NOTE – Before a configuration that contains an instance of the `TcVcMux` FR is used operationally, SM is expected to enforce the constraint that the product of `tcMcMuxMaxFrameLength` and `tcMcMuxMaxNumberOfFramesPerCltu` represents a set of TC frames that, when encoded into a single CLTU using the coding scheme configured for the underlying `TcPlopSyncAndChnlEncode` FR instance, is less than or equal to the value of the `tcPlopSyncMaxCltuLength` parameter of that `TcPlopSyncAndChnlEncode` FR instance.

7.2.2.2.2.4 If the `TcPlopSyncInputDataFormat` configuration parameter of the underlying TC PLOP, Sync, and Channel Encoding FR has the `maxNumberOfCltuRepetitions` choice, then the TC MC Multiplexing FR creates a separate TC channel access frame set for each frame. The value of the `Repetitions` parameter that accompanies each (single-frame) TC channel access frame set that is submitted to the underlying TC PLOP, Sync, and Channel Encoding FR is determined by the virtual channel and QoS/data type (AD or BC) of the frames contained within that TC channel access frame set. Each TC VC Multiplexing FR (see 7.2.3) instance has `tcVcMuxAdFrameRepetitions` and `tcVcMuxBcFrameRepetitions` managed tables that specify the repetitions that are to be applied for the VCs that are handled by that multiplexer instance. The TC MC Multiplexing FR uses the information in those repetitions tables to determine the value of the `Repetitions` parameter that accompanies each TC channel access frame set.

NOTE – The mechanism by which the repetitions information is made available by the TC VC Multiplexing FR instances to the TC MC Multiplexing FR instance that multiplexes their VCs is implementation-dependent.

7.2.2.3 SAPs and Ancillary Interfaces Used by This Functional Resource

7.2.2.3.1 SAPs Accessed by This Functional Resource

The TC MC Multiplexing FR accesses the TC Channel Access Frame Sets SAP.

7.2.2.3.2 SAPs Hosted by This Functional Resource

The TC MC Multiplexing FR has a Transmit MC Frames SAP that can be accessed by multiple instances of the TC VC Multiplexing FR.

7.2.2.3.3 Ancillary Interfaces Required by This Functional Resource

None.

7.2.2.3.4 Ancillary Interfaces Provided by This Functional Resource

None.

7.2.3 TC VC MULTIPLEXING FR

7.2.3.1 General

7.2.3.1.1 The FR classifier of the TC VC Multiplexing FR Type is $TcVcMux$.

7.2.3.1.2 The TC VC Multiplexing FR corresponds to the Virtual Channel Multiplexing function of TC SDLP (reference [17]), which multiplexes the transfer frames from one or more Virtual Channels into a Master Channel.

7.2.3.1.3 The TC VC Multiplexing FR supports the systematic retransmission of transfer frames containing Sequence-Controlled User Data (AD frames) and Expedited Protocol Control information (BC frames), as described in 7.2.3.2.

7.2.3.1.4 The TC VC Multiplexing FR also implements the three multiplexing schemes required by the FF-CSTS (reference [32]): absolute priority, polling vector, and FIFO.

7.2.3.1.5 Table 5-2 of TC SDLP (reference [17]) specifies a set of managed parameters for the Master Channel. All Master Channel managed parameters from that Recommended Standard are reflected in the configuration parameters of the TC VC Multiplexing FR as defined in the SANA Functional Resources registry, except for the managed parameters identified in table 7-2.

Table 7-2: MC Managed Parameters of the VC Multiplexing Function of TC SDLP That Are Not in the Configuration Parameters of the TC VC Multiplexing FR

Excluded Recommended Standard Managed Parameter	Comment
Valid VCIDs	<p>The VCIDs of the frames are either set as part of the configuration of FRs that generate frames from user inputs or are included in the validation parameters of FRs that receive frames from user inputs (i.e., the FF-CSTS). Thus the configuration profile as a whole defines the set of valid VCIDs.</p> <p>For this issue of this Recommended Practice, the only source of TC frames is the Forward Frame service, and the valid VCID for each FwdFrameCstsProvider FR instance is specified by its <code>ffAuthorizedGvcidAndBitMask:</code> <code>tcGvcid: tcVcid</code> parameter.</p>

NOTE – The configuration parameters of the TC VC Multiplexing FR also include parameters that are not explicitly identified as managed parameters in the Recommended Standard.

7.2.3.2 Systematic Retransmission

7.2.3.2.1 Subsection 7.2.2.2 summarizes systematic retransmission as defined in reference [5] and specifies how it is supported by the TC PLOP, Sync, and Channel Coding FR and the TC MC Multiplexing FR.

7.2.3.2.2 Each TC VC Multiplexing FR instance has `tcVcMuxAdFrameRepetitions` and `tcVcMuxBcFrameRepetitions` managed tables that specify the repetitions that are to be applied for the VCs and frame types (AD or BC) that are handled by that multiplexer instance. These repetition values allow the TC MC Multiplexing FR to determine how many times the TC channel access frame sets are to be submitted to the underlying TC PLOP, Sync, and Channel Coding FR.

NOTE – The mechanism by which the repetitions information is made available by the TC VC Multiplexing FR instances to the TC MC Multiplexing FR instance that multiplexes their VCs is implementation-dependent.

7.2.3.3 SAPs and Ancillary Interfaces Used by This Functional Resource

7.2.3.3.1 SAPs Accessed by This Functional Resource

The TC VC Multiplexing FR accesses the Transmit MC Frames SAP of a TC MC Multiplexing FR.

7.2.3.3.2 Resource SAPs Hosted by This Functional

The TC VC Multiplexing FR has a Transmit VC Frames Minus FECF SAP that can be accessed by multiple Accessors. The SAP uses the GVCID of the frame to determine the VC into which the frame is to be multiplexed.

7.3 AOS SPACE LINK PROTOCOL TRANSMISSION FUNCTIONAL RESOURCE SET OF THE SPACE LINK PROTOCOL TRANSMISSION FUNCTIONAL RESOURCE STRATUM

7.3.1 OVERVIEW

The FR Types that compose the AOS Space Link Protocol Transmission FR Set of the Space Link Protocol Transmission FR Stratum are:

- a) AOS MC Multiplexing; and
- b) AOS VC Multiplexing.

Figure 7-3 illustrates the internal composition of the AOS Space Link Protocol Transmission FR Set.

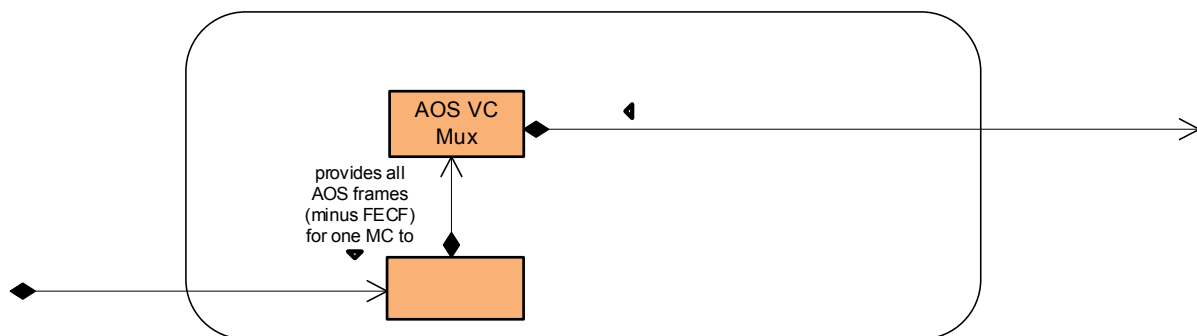

Figure 7-3: Members of the AOS Space Link Protocol Transmission Functional Resource Set

NOTE – The AOS Space Link Protocol Transmission FR Set may be expanded in the future to include FRs that represent the Virtual Channel Generation (and above) functions of the Sending End of AOS SDLP (reference [18]).

7.3.2 AOS MC MULTIPLEXING

7.3.2.1 General

7.3.2.1.1 The FR classifier of the AOS MC Multiplexing FR Type is `AoSMcMux`.

7.3.2.1.2 The AOS MC Multiplexing FR corresponds to the following functions:

- a) the Master Channel Multiplexing function of AOS SDLP (reference [18]), which multiplexes the transfer frames from one or more Master Channels into a single stream of transfer frames and creates Only Idle Data Transfer Frames to preserve the continuity of the transmitted stream in the event that there are no valid Transfer Frames available for transmission at a release time; and
- b) the All Frames Generation function of AOS SDLP, which optionally adds an FECF to the trailer of each frame.

7.3.2.1.3 The AOS MC Multiplexing FR implements the three multiplexing schemes required by the FF-CSTS (reference [32]): absolute priority, polling vector, and FIFO.

NOTES

- 1 The All Frames Generation function of AOS SDLP is also the insertion point for Insert Service Data Units (SDUs). If the Insert SLE transfer service (or an equivalent CSTS) were ever to be implemented, its functionality would be added to the AOS MC Multiplexing FR. However, at the time of this writing, there are no plans to implement a cross-supported Insert service.
- 2 The All Frames Generation function of AOS SDLP also optionally adds a Frame Header Error Control (FHEC) value in the last two octets of the Transfer Frame Primary Header, which is not required to be supported in cross support. Computation and insertion of the AOS FHEC field is *not* performed by the AOS MC Multiplexing FR. However, AOS frames users of the FF-CSTS may include FHEC in their AOS transfer frames, as such FHEC fields would be opaque to the FF service and the underlying production process.

7.3.2.1.4 Table 5-1 of AOS SDLP (reference [18]) specifies a set of managed parameters for the Physical Channel. All Physical Channel managed parameters from that Recommended Standard are reflected in the configuration parameters of the AOS MC Multiplexing FR as defined in the SANA Functional Resources registry, except for the managed parameters identified in table 7-3.

Table 7-3: PC Managed Parameters of AOS SDLP That Are Not in the Configuration Parameters of the AOS MC Multiplexing FR

Excluded Recommended Standard Managed Parameter	Comment
Physical Channel Name	The Physical Channel Name is specified in the <code>xxxPhysChnlName</code> parameters of the Physical Channel Stratum FRs. The AOS MC Multiplexing FR inherits the value of this parameter from the Physical Channel Stratum FR with which it is associated in the operational configuration.
Transfer Frame Length	The transfer frame length is equal to the <code>tmSyncEncFrameLength</code> parameter of TM Synchronization and Channel Encoding FR instance with which the AOS MC Mux instance is associated.
Transfer Frame Version Number	For AOS, this value is fixed to version 2 ('01' binary) and is not configurable.
Valid Spacecraft IDs	The spacecraft IDs of the frames are either set as part of the configuration of FRs that generate frames from user inputs or are included in the validation parameters of FRs that receive frames from user inputs (i.e., the FF-CSTS). Thus the configuration profile as a whole defines the set of valid SCIDs. For this issue of this Recommended Practice, the only source of AOS frames is the Forward Frame service, and the valid SCID for each <code>FwdFrameCstsProvider</code> FR instance is specified by its <code>ffAuthorizedGvcidAndBitMask</code> : <code>aosGvcid</code> : <code>aosScid</code> parameter.
Presence of Frame Header Error Control	As described in 7.3.2.1 NOTE 2 above, the AOS MC Multiplexing FR does not compute or inject Frame Header Error Control octets into the AOS Transfer Frame header.
Presence of Insert Zone and Insert Zone Length	As stated in 7.3.2.1 NOTE 1 above, at the time of this writing, there are no plans to implement a cross-supported Insert service. If the Insert SLE transfer service (or an equivalent CSTS) were ever to be implemented, its functionality would be added to the AOS MC Multiplexing FR and appropriate configuration parameter(s) added.

NOTES

- 1 The configuration parameters of the AOS MC Multiplexing FR also include parameters that are not explicitly identified as managed parameters in the Recommended Standard.
- 2 Figure 7-4 illustrates the sublayers of the AOS MC Multiplexing FR.

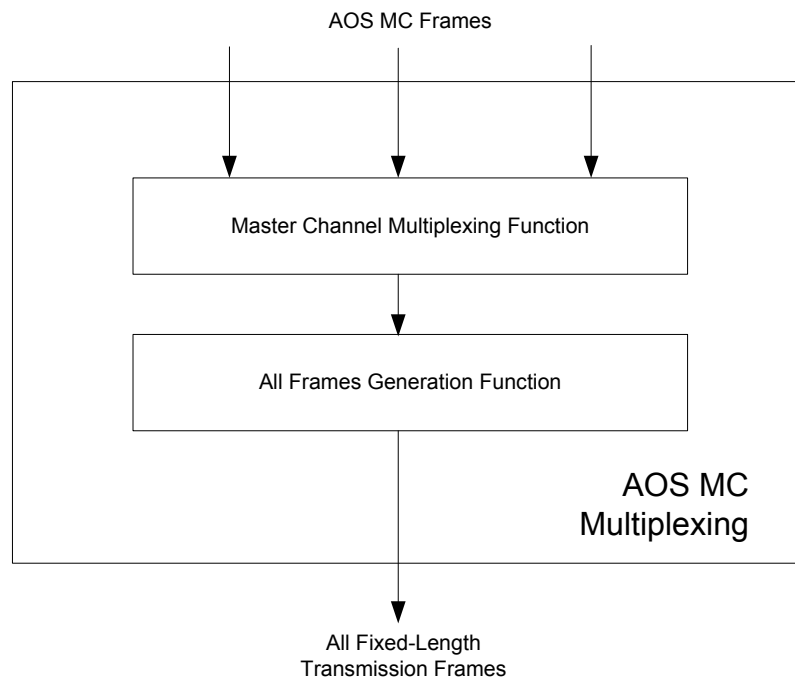

Figure 7-4: Internal Structure of the AOS MC Multiplexing Functional Resource

7.3.2.2 SAPs and Ancillary Interfaces Used by This Functional Resource

7.3.2.2.1 SAPs Accessed by This Functional Resource

The AOS MC Multiplexing FR accesses the Transmit-Fixed-Length Frames SAP.

7.3.2.2.2 SAPs Hosted by This Functional Resource

The AOS MC Multiplexing FR has a Transmit MC Frames SAP that can be accessed by multiple sources of AOS MC frames.

7.3.2.2.3 Ancillary Interfaces Required by This Functional Resource

None.

7.3.2.2.4 Ancillary Interfaces Provided by This Functional Resource

None.

7.3.3 AOS VC MULTIPLEXING

7.3.3.1 General

7.3.3.1.1 The FR classifier of the AOS VC Multiplexing FR Type is `AoSVcMux`.

7.3.3.1.2 The AOS VC Multiplexing FR corresponds to the Virtual Channel Multiplexing function of AOS SDLP (reference [18]), which multiplexes the transfer frames from one or more Virtual Channels into a single Master Channel.

7.3.3.1.3 The AOS VC Multiplexing FR also implements the three multiplexing schemes required by the FF CSTS (reference [32]): absolute priority, polling vector, and FIFO.

NOTE – The VC Multiplexing function defined in AOS SDLP also provides for generation of Only Idle Data Frames in the absence of user-data-bearing transfer frames from any of the input VCs or from a single Master Channel on the Physical Channel. However, Only Idle Data Frame generation by VC Multiplexing is redundant with the Only Idle Data Frame generation performed by the MC Multiplexing function and is therefore omitted by the AOS VC Multiplexing FR.

7.3.3.1.4 Table 5-2 of AOS SDLP (reference [18]) specifies a set of managed parameters for the Master Channel. All Master Channel managed parameters from that Recommended Standard are reflected in the configuration parameters of the AOS VC Multiplexing FR as defined in the SANA Functional Resources registry, except for the managed parameters identified in table 7-4.

Table 7-4: MC Managed Parameters of the VC Multiplexing Function of AOS SDLP That Are Not in the Configuration Parameters of the AOS VC Multiplexing FR

Excluded Recommended Standard Managed Parameter	Comment
Valid VCIDs	<p>The VCIDs of the frames are either set as part of the configuration of FRs that generate frames from user inputs or are included in the validation parameters of FRs that receive frames from user inputs (i.e., the FF-CSTS). Thus the configuration profile as a whole defines the set of valid VCIDs.</p> <p>For this issue of this Recommended Practice, the only source of AOS frames is the Forward Frame service, and the valid VCID for each <code>FwdFrameCstsProvider</code> FR instance is specified by its <code>ffAuthorizedGvcidAndBitMask: aosGvcid: aosVcid</code> parameter.</p>

NOTE – The configuration parameters of the AOS VC Multiplexing FR also include parameters that are not explicitly identified as managed parameters in the Recommended Standard.

7.3.3.2 SAPs and Ancillary Interfaces Used by This Functional Resource

7.3.3.2.1 SAPs Accessed by This Functional Resource

The AOS VC Multiplexing FR accesses the Transmit MC Frames SAP of the AOS MC Multiplexing FR.

7.3.3.2.2 SAPs Hosted by This Functional Resource

The AOS VC Multiplexing FR has a Transmit VC Frames Minus FECF SAP that can be accessed by multiple Accessors. The SAP uses the GVCID of the frame to determine the VC into which the frame is to be multiplexed.

7.3.3.2.3 Ancillary Interfaces Required by This Functional Resource

None.

7.3.3.2.4 Ancillary Interfaces Provided by This Functional Resource

None.

7.4 VARIABLE LENGTH FRAME UNIFIED SPACE DATA LINK PROTOCOL TRANSMISSION FUNCTIONAL RESOURCE SET OF THE SPACE LINK PROTOCOL FUNCTIONAL RESOURCE STRATUM

7.4.1 OVERVIEW

NOTE – This FR Set corresponds to the sending-end functionality, specified in CCSDS 732.1 (reference [34]), that is applicable to variable-length frames.

USLP is capable of using both variable-length and fixed-length transfer frames; for any given space link physical channel, USLP must use either fixed-length or variable-length frames. This FR Set represents the VLF functionality of USLP on the transmitted link.

The FR Types that make up the VLF Unified Space Link Protocol Transmission FR Set of the Space Link Protocol FR Stratum are:

- a) VLF USLP MC Multiplexing; and
- b) VLF USLP VC Multiplexing.

Figure 7-5 illustrates the FR Types that constitute the VLF Unified Space Link Protocol Transmission FR Set.

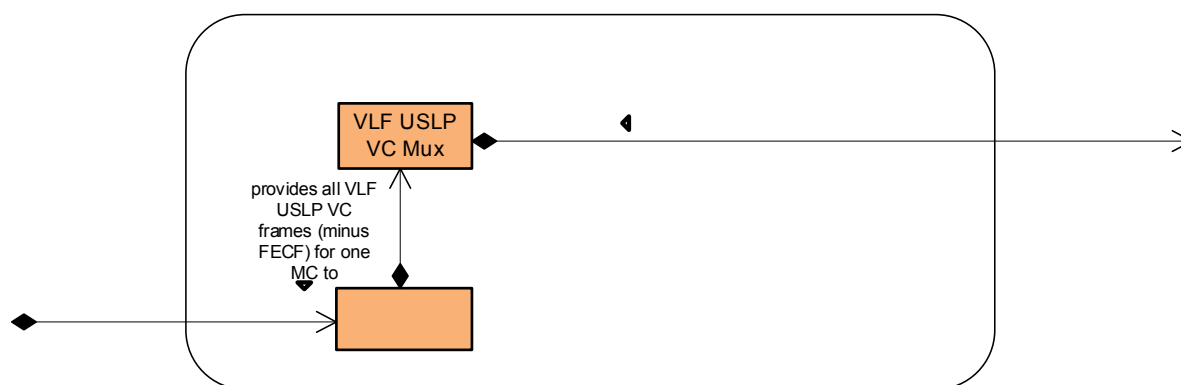

Figure 7-5: Member Functional Resources of the VLF Unified Space Link Protocol Transmission Functional Resource Set

NOTE – The VLF Unified Space Link Protocol Transmission FR Set may be expanded in the future to include FRs that represent the Virtual Channel Generation (and above) functions of the Sending End of USLP (reference [34]).

7.4.2 VLF USLP MC MULTIPLEXING FR

7.4.2.1 General

7.4.2.1.1 The FR classifier of the VLF USLP MC Multiplexing FR Type is `VlfUslpMcMux`.

7.4.2.1.2 The VLF USLP MC Multiplexing FR corresponds to the following functions:

- a) the variable-length frame processing of the Master Channel Multiplexing function of USLP (reference [34]), which multiplexes the variable-length transfer frames from one or more Master Channels into a single stream of transfer frames;
- b) the variable-length frame processing of the All Frames Generation function of the *Unified Space Data Link Protocol* Recommended Standard, which optionally adds an FECF to the trailer of each frame and submits each transfer frame to the underlying variable-length-frame Synchronization and Channel Coding FR (e.g., a TC PLOP, Synchronization and Channel Encoding FR instance).

7.4.2.1.3 The VLF USLP MC Multiplexing FR also implements the three multiplexing schemes required by the FF-CSTS (reference [32]): absolute priority, polling vector, and FIFO.

7.4.2.1.4 The VLF USLP MC Multiplexing FR also implements the systematic retransmission of transfer frames containing AD or BC, as described in 7.4.2.2.

NOTE – Unlike TC SDLP, USLP (when using variable-length transfer frames) does not support multiple transfer frames per CLTU. Therefore each TC Channel Access Frame Set is constrained to contain only one transfer frame.

7.4.2.1.5 Table 5-1 of USLP (reference [34]) specifies a set of managed parameters for the Physical Channel. All Physical Channel managed parameters from that Recommended Standard are reflected in the configuration parameters of the VLF USLP MC Multiplexing FR as defined in the SANA Functional Resources registry, except for the managed parameters identified in table 7-5.

Table 7-5: PC Managed Parameters of USLP That Are Not in the Configuration Parameters of the VLF USLP MC Multiplexing FR

Excluded Recommended Standard Managed Parameter	Comment
Physical Channel Name	The Physical Channel Name is specified in the xxxPhysChnlName parameters of the Physical Channel Stratum FRs. The VLF USLP MC Multiplexing FR inherits the value of this parameter from the Physical Channel Stratum FR with which it is associated in the operational configuration.
Transfer Frame Type	For the VLF USLP MC Multiplexing FR the Transfer Frame Type is always ‘variable length’ and is not configurable.
Transfer Frame Version Number	For USLP, this value is fixed to ‘1100’ binary and is not configurable.
Presence of Insert Zone and Insert Zone Length	Insert Service and Insert Zones are possible only for fixed-length frames.
Generate Only Idle Data Frame	The Only Idle Data Frame generation function is applicable only to fixed-length frames.
Maximum Number of Transfer Frames Given to the Coding and Synchronization Sublayer as a Single Data Unit	This value is always 1 for fixed-length frames and is not configurable.
Maximum Value of the Repetitions Parameter to the Coding and Synchronization Sublayer	This value is specified by the TcPlopSyncInputDataFormat: frame: maxCltuRepetitionsMaxFramesPerCltu: maxNumberOfCltuRepetitions configuration parameter of the underlying TC PLOP, Sync, and Channel Encoding FR.

NOTES

- 1 The configuration parameters of the VLF USLP MC Multiplexing FR also include parameters that are not explicitly identified as managed parameters in the Recommended Standard.
- 2 Figure 7-6 illustrates the sublayers of the VLF USLP MC Multiplexing FR.

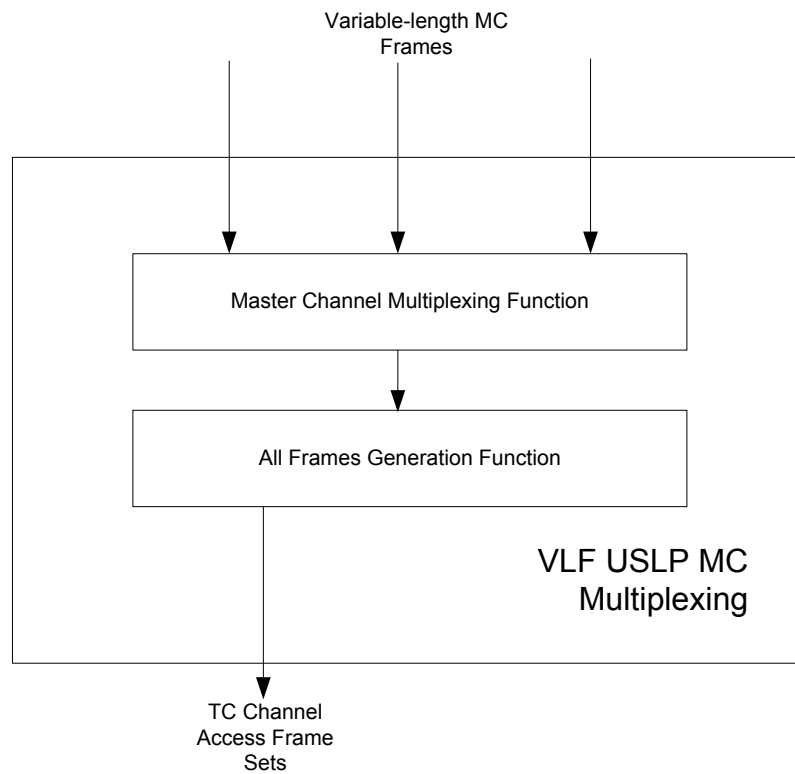

Figure 7-6: Internal Structure of the VLF USLP MC Multiplexing Functional Resource

7.4.2.2 Systematic Retransmission

7.4.2.2.1 CCSDS Systematic Retransmission

The *TC Synchronization and Channel Coding* Recommended Standard (reference [5]) specifies a mechanism for the systematic retransmission of CLTUs. As specified in reference [5], the TC Synchronization and Channel Coding sublayer provides a Channel Access service interface through which the SDLP above it submits a set of frames, optionally accompanied by a *Repetitions* parameter. The set of frames, referred to as a *TC channel access frame set* in this Recommended Practice (see 6.2.2.2 NOTE 1), constitutes the set of frames from which the TC Sync and Channel Coding sublayer forms the CLTU. TC SDLP (reference [17]) defines managed parameters that specify the values of the *Repetitions* parameter for each VC for frames of two Quality of Service (QoS)/data types: AD or BC. Frames using BD QoS/data cannot be systematically retransmitted; that is, they are transmitted only once. If the *Repetitions* parameter has a value greater than one, then the TC Sync and Channel Coding sublayer transmits that CLTU *Repetitions* number of times.

7.4.2.2.2 Systematic Retransmission as Performed by the VLF USLP MC Multiplexing Functional Resource

7.4.2.2.2.1 As specified in TC SDLP (reference [17]), the All Frames Generation function generates the TC channel access frame sets and the accompanying Repetitions parameter values to form the `ServiceAccess.Request` primitives. This function is performed by the VLF USLP MC Multiplexing FR.

7.4.2.2.2.2 As described in 6.2.2.2, the TC PLOP, Sync, and Channel Encoding FR constrains the use of systematic retransmission to CLTUs that each contain a single transfer frame. The constraint is specified through the `tcPlopSyncInputDataFormat: frame: maxCltuRepetitionsMaxFramesPerCltu` configuration parameter, which has two CHOICES: (a) the `maxNumberOfFramesPerCltu` choice is used to specify that multiple-frame CLTUs is supported by the FR instance, and (b) the `maxNumberOfCltuRepetitions` choice is used to specify that repeated transmission of multiple single-frame CLTUs is supported by the FR instance. If the `maxNumberOfFramesPerCltu` choice is used, the presence and/or value of the Repetitions parameter is ignored, and each CLTU is transmitted only once, regardless of the number of frames within the TC channel access frame set.

7.4.2.2.2.3 USLP (reference [34]) does not support multiple frames per CLTU. Therefore when configured to transfer VLF USLP frames, the TC PLOP, Sync, and Channel Encoding FR configuration parameter `tcPlopSyncInputDataFormat` must be set to the `frame: maxCltuRepetitionsMaxFramesPerCltu: maxNumberOfCltuRepetitions` choice. The TC MC Multiplexing FR creates a separate TC channel access frame set for each frame. The value of the Repetitions parameter that accompanies each (single-frame) TC channel access frame set that is submitted to the underlying TC PLOP, Sync, and Channel Encoding FR is determined by the virtual channel and QoS/data type (AD or BC) of the frames contained within that TC channel access frame set. Each VLF USLP VC Multiplexing FR (see 7.4.3) instance has `vlfUslpVcMuxAdFrameRepetitions` and `vlfUslpVcMuxBcFrameRepetitions` managed tables that specify the repetitions that are to be applied for the VCs that are handled by that multiplexer instance. The VLF USLP MC Multiplexing FR uses the information in those repetitions tables to determine the value of the Repetitions parameter that accompanies each TC channel access frame set.

NOTE – The mechanism by which the repetitions information is made available by the VLF USLP VC Multiplexing FR instances to the VLF USLP MC Multiplexing FR instance that multiplexes their VCs is implementation-dependent.

7.4.2.2.2.4 VLF USLP defines both truncated and non-truncated (i.e., ‘normal’) transfer frames. Non-truncated transfer frames carry the Bypass/Sequence Control Flag and Protocol Control Command Flag bits that specify the QoS/data type of each frame. These flags are absent from truncated variable-length USLP frames. Truncated transfer frames have a Repetitions value of ‘1’.

7.4.2.3 SAPs and Ancillary Interfaces Used by This Functional Resource

7.4.2.3.1 SAPs Accessed by This Functional Resource

The VLF USLP MC Multiplexing FR accesses the TC Channel Access Frame Sets SAP.

7.4.2.3.2 SAPs Hosted by This Functional Resource

The VLF USLP MC Multiplexing FR has a Transmit MC Frames SAP that can be accessed by multiple instances of the VLF USLP VC Multiplexing FR.

7.4.2.3.3 Ancillary Interfaces Required by This Functional Resource

None.

7.4.2.3.4 Ancillary Interfaces Provided by This Functional Resource

None.

7.4.3 VLF USLP VC MULTIPLEXING FR

7.4.3.1 General

7.4.3.1.1 The FR classifier of the VLF USLP VC Multiplexing FR Type is `VlfUslpVcMux`.

7.4.3.1.2 The VLF USLP VC Multiplexing FR corresponds to the variable-length-frame processing of the Virtual Channel Multiplexing function of USLP (reference [34]), which multiplexes the transfer frames from one or more Virtual Channels into a single stream of transfer frames.

7.4.3.1.3 The VLF USLP VC Multiplexing FR supports the systematic retransmission of transfer frames containing Sequence-Controlled User Data (AD frames) or Expedited Protocol Control information (BC frames), as described in 7.4.3.2.

7.4.3.1.4 The VLF USLP VC Multiplexing FR also implements the three multiplexing schemes required by the FF-CSTS (reference [32]): absolute priority, polling vector, and FIFO.

NOTE – USLP specifies the Master Channel Generation function, the purpose of which is to optionally commutate four-octet data units into the Operational Control Field (OCF) of the transfer frames of designated virtual channels. When implemented in an ESLT, USLP does not support the commutation of OCFs into transfer frames, and so that functionality is excluded from the version 1 VLF USLP VC Multiplexing FR. If and when the scope of the USLP FRs is expanded to include OCF commutation, that functionality will be added to the VLF USLP VC Multiplexing FR.

7.4.3.1.5 Table 5-2 of USLP (reference [34]) specifies a set of managed parameters for the Master Channel. All Master Channel managed parameters from that Recommended Standard are reflected in the configuration parameters of the VLF USLP VC Multiplexing FR as defined in the SANA Functional Resources registry, except for the managed parameters identified in table 7-6.

Table 7-6: MC Managed Parameters of the VC Multiplexing Function of USLP That Are Not in the Configuration Parameters of the VLF USLP VC Multiplexing FR

Excluded Recommended Standard Managed Parameter	Comment
Transfer Frame Type	For the VLF USLP VC Multiplexing FR, this is always ‘variable length’ and not configurable.
VCIDs	<p>The VCIDs of the frames are either set as part of the configuration of FRs that generate frames from user inputs or are included in the validation parameters of FRs that receive frames from user inputs (i.e., the FF-CSTS). Thus the configuration profile as a whole defines the set of VCIDs.</p> <p>For this issue of this Recommended Practice, the only source of USLP frames is the Forward Frame service, and the valid VCID for each FwdFrameCstsProvider FR instance is specified by its <code>ffAuthorizedGvcidAndBitMask</code>: <code>uslpGvcid: uslpVcid</code> parameter.</p>

NOTE – The configuration parameters of the VLF USLP VC Multiplexing FR also include parameters that are not explicitly identified as managed parameters for the Master Channel in the Recommended Standard.

7.4.3.2 Systematic Retransmission

7.4.3.2.1 Subsection 7.4.2.2 summarizes systematic retransmission, as defined in reference [5], and how it is supported by the TC PLOP, Sync, and Channel Coding FR and the VLF USLP MC Multiplexing FR.

7.4.3.2.2 Each VLF USLP VC Multiplexing FR instance has `vlfUslpVcMuxAdFrameRepetitions` and `vlfUslpVcMuxBcFrameRepetitions` managed tables that specify the repetitions that are to be applied for the VCs and frame types (AD or BC) that are handled by that multiplexer instance. These repetition values allow the VLF USLP MC Multiplexing FR to determine how many times the (single frame) TC channel access frame sets are to be submitted to underlying TC PLOP, Sync, and Channel Coding FR. For truncated frames, the repetition value is always '1'.

NOTE – The mechanism by which the repetitions information is made available by the VLF USLP VC Multiplexing FR instances to the VLF USLP MC Multiplexing FR instance that multiplexes their VCs is implementation-dependent.

7.4.3.3 SAPs and Ancillary Interfaces Used by This Functional Resource

7.4.3.3.1 SAPs Accessed by This Functional Resource

The VLF USLP VC Multiplexing FR accesses the Transmit MC Frames SAP of a VLF USLP MC Multiplexing FR.

7.4.3.3.2 SAPs Hosted by This Functional Resource

The VLF USLP VC Multiplexing FR has a VC Frames Minus FECF SAP that can be accessed by multiple Accessors. The SAP uses the GVCID of the frame to determine the VC into which the frame is to be multiplexed.

7.4.3.3.3 Ancillary Interfaces Required by This Functional Resource

None.

7.4.3.3.4 Ancillary Interfaces Provided by This Functional Resource

None.

7.5 FIXED LENGTH FRAME UNIFIED SPACE DATA LINK PROTOCOL TRANSMISSION FUNCTIONAL RESOURCE SET OF THE SPACE LINK PROTOCOL FUNCTIONAL RESOURCE STRATUM

7.5.1 OVERVIEW

USLP (reference [34]) is capable of using both variable-length and fixed-length transfer frames; for any given space link physical channel USLP must use either fixed-length or variable-length frames. This FR Set represents the FLF functionality of USLP on the transmitting end.

The FR Types that make up the FLF Unified Space Link Protocol Transmission FR Set of the Space Link Protocol FR Stratum are:

- a) FLF USLP MC Multiplexing; and
- b) FLF USLP VC Multiplexing.

Figure 7-7 illustrates the FR Types that constitute the FLF Unified Space Link Protocol Transmission FR Set.

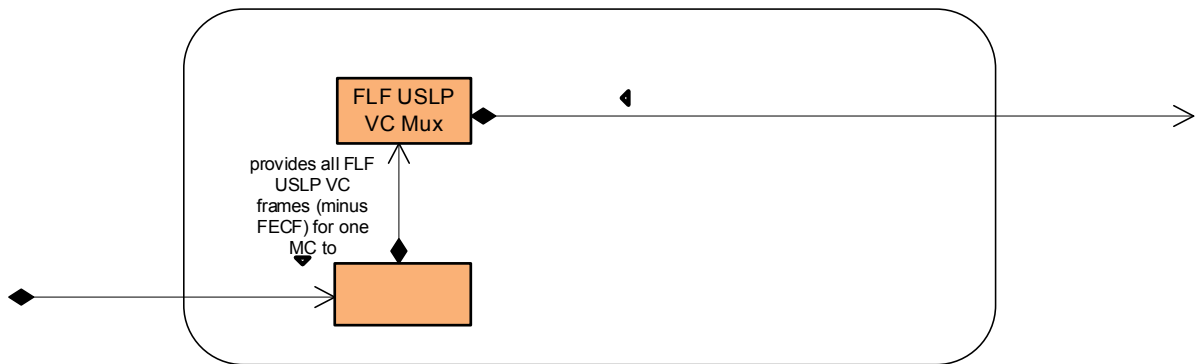

Figure 7-7: Member Functional Resources of the FLF Unified Space Link Protocol Transmission Functional Resource Set

NOTE – The FLF USLP Transmission FR Set may be expanded in the future to include FRs that represent the Virtual Channel Generation (and above) functions of the Sending End of USLP (reference [34]).

7.5.2 FLF USLP MASTER CHANNEL MULTIPLEXING FR

7.5.2.1 General

7.5.2.1.1 The FR classifier of the FLF USLP MC Multiplexing FR Type is `FlfUslpMcMux`.

7.5.2.1.2 The FLF USLP MC Multiplexing FR corresponds to the following functions:

- a) the fixed-length frame processing of the Master Channel Multiplexing function of USLP (reference [34]), which multiplexes the fixed-length transfer frames from one or more Master Channels into a single stream of transfer frames and creates Only Idle Data Transfer Frames to preserve the continuity of the transmitted stream in the event that there are no valid Transfer Frames available for transmission at a release time; and
- b) the fixed-length frame processing of the All Frames Generation function of USLP, which optionally adds an FECF to the trailer of each frame and submits each transfer frame to the underlying fixed-length frame-handling Synchronization and Channel Coding FR (e.g., a TM Synchronization and Channel Encoding FR instance).

7.5.2.1.3 The FLF USLP MC Multiplexing FR also implements the three multiplexing schemes required by the FF-CSTS (reference [32]): absolute priority, polling vector, and FIFO.

NOTE – The USLP All Frames Generation function defined in reference [34] also provides for the insertion of Insert SDUs. If the Insert SLE transfer service (or an equivalent CSTS) were ever to be implemented, its functionality would be added to the USLP MC Multiplexing FR. However, at the time of this writing, there are no plans to implement a cross-supported Insert service.

7.5.2.1.4 Table 5-1 of USLP (reference [34]) specifies a set of managed parameters for the Physical Channel. All Physical Channel managed parameters from that Recommended Standard are reflected in the configuration parameters of the FLF USLP MC Multiplexing FR as defined in the SANA Functional Resources registry, except for the managed parameters identified in table 7-7.

Table 7-7: PC Managed Parameters of USLP That Are Not in the Configuration Parameters of the FLF USLP MC Multiplexing FR

Excluded Recommended Standard Managed Parameter	Comment
Physical Channel Name	The Physical Channel Name is specified in the <code>xxxPhysChnlName</code> parameters of the Physical Channel Stratum FRs. The FLF USLP MC Multiplexing FR inherits the value of this parameter from the Physical Channel Stratum FR with which it is associated in the operational configuration.
Physical Channel Transfer Frame Type	For the FLF USLP MC Multiplexing FR, the Transfer Frame Type is always 'fixed length' and is not configurable.
Transfer Frame Length	The transfer frame length is equal to the <code>tmSyncEncFrameLength</code> parameter of the TM Synchronization and Channel Encoding FR instance with which the FLF USLP MC Mux instance is associated.
TFVN (Transfer Frame Version Number)	For USLP, this value is fixed to '1100' binary and is not configurable.
Presence of Insert Zone and Insert Zone Length	As stated in the note under 7.5.2, at the time of this writing, there are no plans to implement a cross-supported Insert service. If the Insert SLE transfer service (or an equivalent CSTS) were ever to be implemented, its functionality would be added to the USLP MC Multiplexing FR and appropriate configuration parameter(s) added.
Maximum Number of Transfer Frames Given to the Coding and Sync Sublayer as a Single Data Unit	This value is always 1 for fixed-length frames and is not configurable.
Maximum Value of the Repetitions Parameter to the Coding and Synchronization Sublayer	Repetition of frames to the C&S sublayer is not applicable to fixed-length frames.

NOTES

- 1 The configuration parameters of the FLF USLP MC Multiplexing FR also include parameters that are not explicitly identified as managed parameters in the Recommended Standard.
- 2 Figure 7-8 illustrates the sublayers of the FLF USLP MC Multiplexing FR.

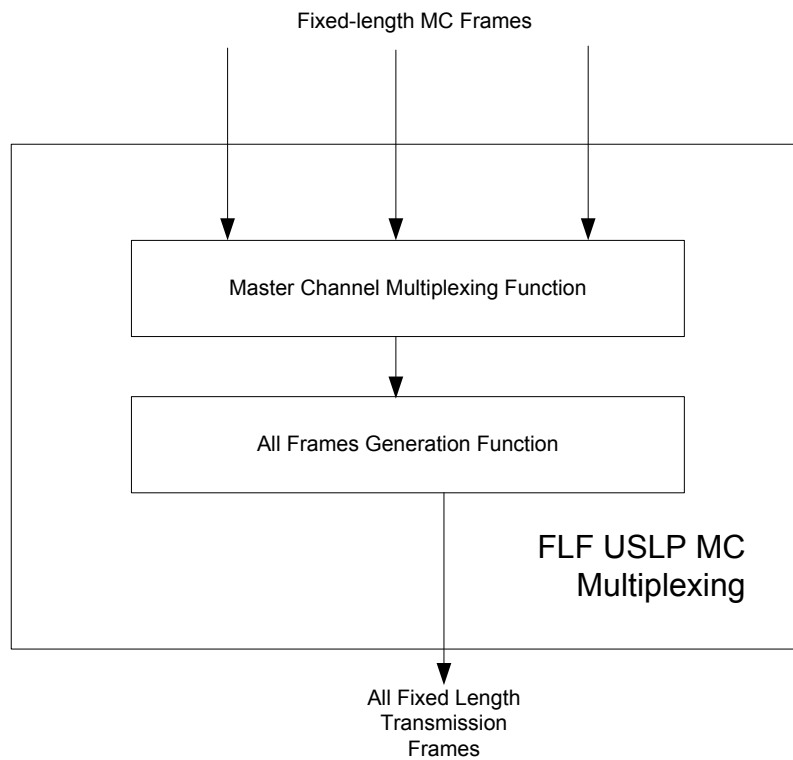

Figure 7-8: Internal Structure of the FLF USLP MC Multiplexing Functional Resource

7.5.2.2 SAPs and Ancillary Interfaces Used by This Functional Resource

7.5.2.2.1 SAPs Accessed by This Functional Resource

The FLF USLP MC Multiplexing FR accesses the Transmit Fixed Length Frames SAP.

7.5.2.2.2 SAPs Hosted by This Functional Resource

The FLF USLP MC Multiplexing FR has a Transmit MC Frames SAP that can be accessed by multiple sources of FLF USLP VC frames.

7.5.2.2.3 Ancillary Interfaces Required by This Functional Resource

None.

7.5.2.2.4 Ancillary Interfaces Provided by This Functional Resource

None.

7.5.3 FLF USLP VC MULTIPLEXING

7.5.3.1 General

7.5.3.1.1 The FR classifier of the FLF USLP VC Multiplexing FR Type is `FlfUslpVcMux`.

7.5.3.1.2 The FLF USLP VC Multiplexing FR corresponds to the fixed-length-frame processing of the Virtual Channel Multiplexing function of USLP (reference [34]), which multiplexes the transfer frames from one or more Virtual Channels into a single stream of transfer frames.

NOTE – USLP specifies the Master Channel Generation function, the purpose of which is to optionally commutate four-octet data units into the OCF of the transfer frames of designated virtual channels. When implemented in an ESLT, USLP does not support the commutation of OCFs into transfer frames, and so that functionality is excluded from the version 1 FLF USLP VC Multiplexing FR. If and when the scope of the USLP functional resources is expanded to include OCF commutation, that functionality will be added to the FLF USLP VC Multiplexing FR.

7.5.3.1.3 The FLF USLP VC Multiplexing FR also implements the three multiplexing schemes required by the FF-CSTS (reference [32]): absolute priority, polling vector, and FIFO.

7.5.3.1.4 Table 5-2 of USLP (reference [34]) specifies a set of managed parameters for the Master Channel. All Master Channel managed parameters from that Recommended Standard are reflected in the configuration parameters of the FLF USLP VC Multiplexing FR as defined in the SANA Functional Resources registry, except for the managed parameters identified in table 7-8.

Table 7-8: MC Managed Parameters of USLP That Are Not in the Configuration Parameters of the FLF USLP VC Multiplexing FR

Excluded Recommended Standard Managed Parameter	Comment
Transfer Frame Type	For the FLF USLP VC Multiplexing FR this is always ‘fixed length’ and not configurable.
VCIDs	<p>The VCIDs of the frames are either set as part of the configuration of FRs that generate frames from user inputs or are included in the validation parameters of FRs that receive frames from user inputs (i.e., the FF-CSTS). Thus the configuration profile as a whole defines the set of VCIDs.</p> <p>For this issue of this Recommended Practice, the only source of USLP frames is the Forward Frame service, and the valid VCID for each FwdFrameCstsProvider FR instance is specified by its <code>ffAuthorizedGvcidAndBitMask: uslpGvcid: uslpVcid</code> parameter.</p>
Inclusion of OCF Required	When implemented in an ESLT, USLP does not support the commutation of OCFs into transfer frames, and so that functionality is excluded from the version 1 FLF USLP VC Multiplexing FR.

NOTE – The configuration parameters of the FLF USLP VC Multiplexing FR also include parameters that are not explicitly identified as managed parameters in the Recommended Standard.

7.5.3.2 SAPs and Ancillary Interfaces Used by This Functional Resource

7.5.3.2.1 SAPs Accessed by This Functional Resource

The FLF USLP VC Multiplexing FR accesses the Transmit MC Frames SAP of the FLF USLP MC Multiplexing FR.

7.5.3.2.2 SAPs Hosted by This Functional Resource

The FLF USLP VC Multiplexing FR has a Transmit VC Frames Minus FECF SAP that can be accessed by multiple Accessors. The SAP uses the GVCID of the frame to determine the VC into which the frame is to be multiplexed.

7.5.3.2.3 Ancillary Interfaces Required by This Functional Resource

None.

7.5.3.2.4 Ancillary Interfaces Provided by This Functional Resource

None.

7.6 TM/AOS SPACE LINK PROTOCOL RECEPTION FUNCTIONAL RESOURCE SET OF THE SPACE LINK PROTOCOL FUNCTIONAL RESOURCE STRATUM

7.6.1 OVERVIEW

The FR Types that make up the TM/AOS Space Link Protocol Reception FR Set of the Space Link Protocol Reception FR Stratum are:

- a) TM/AOS MC Demultiplexing; and
- b) TM/AOS VC Demultiplexing.

NOTE – The All Frames Reception function is formally defined as part of the TM and AOS SDLPs. For TM, the All Frames Reception function consists of error detection on the FECF. For AOS, the All Frames Reception function consists of error detection on the FECF and extraction of Insert SDUs. With respect to error detection on the FECF, this functionality is included in the TM Synchronization and Channel Decoding FR (6.4.2) so that the resultant annotated transfer frames reflect all error detection and/or correction performed on those frames. With respect to extraction of AOS Insert SDUs, there are currently no cross support devices defined for processing or delivering Insert SDUs.

Figure 7-9 illustrates the internal composition of the TM/AOS Space Link Protocol Reception FR Set.

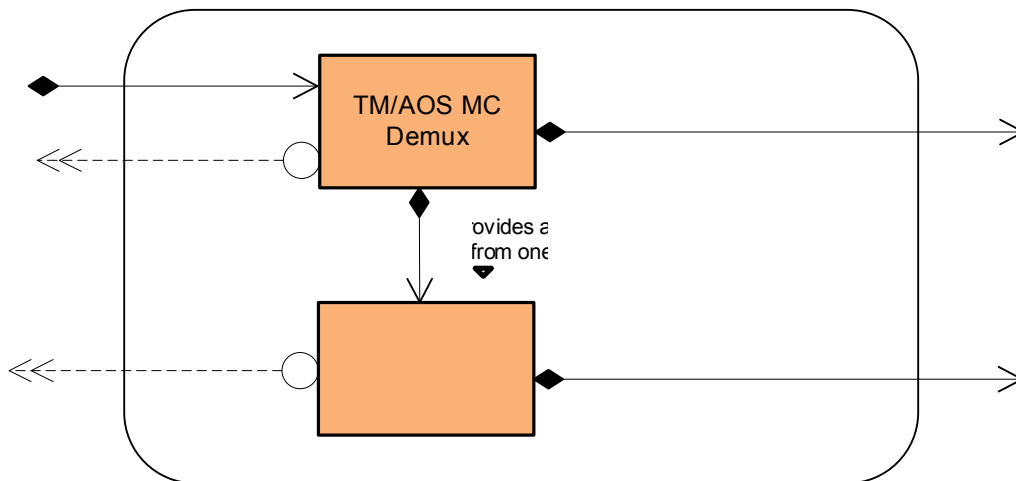

Figure 7-9: Member Functional Resources of the TM/AOS Space Link Protocol Reception Functional Resource Set

NOTE – The TM/AOS Space Link Protocol Reception FR Set may be expanded in the future to include FRs that represent the Virtual Channel Reception (and above) functions of the Receiving End of AOS and TM SDLPs (references [18] and [19]).

7.6.2 TM/AOS MC DEMULTIPLEXING

7.6.2.1 General

7.6.2.1.1 The FR classifier of the TM/AOS MC Demultiplexing FR Type is TmAosMcDemux.

7.6.2.1.2 The TM/AOS MC Demultiplexing FR corresponds to:

- a) the MC Demultiplexing function of TM SDLP (reference [19]);
- b) the MC Demultiplexing function of AOS SDLP (reference [18]); and
- c) the MC_OCF extraction subfunction of the Master Channel Reception function of TM SDLP.

NOTES

- 1 The All Frames Reception function of the TM and AOS SDLPs are defined to perform the FECF decoding function. In the FRM, FECF decoding is performed by the TM Synchronization and Channel Decoding FR.
- 2 The All Frames Reception function of AOS SDLP is also the extraction point for Insert SDUs. If the Insert SLE transfer service (or an equivalent CSTS) were ever to be implemented, its functionality would be added to the TM/AOS MC Demultiplexing FR. However, at the time of this writing, there are no plans to implement a cross-supported Insert service.
- 3 The All Frames Reception function of AOS SDLP also includes the FHEC decoding function. The presence of the FHEC field is opaque to the TM/AOS MC Demultiplexing FR, and plays no part in the validation of the frames by the TM/AOS MC Demultiplexing FR.
- 4 There is no MC Reception function in AOS SDLP.
- 5 The MC Reception function of TM SDLP also includes an MC Frame Secondary Header (FSH) Decommuration subfunction. There is no standard CCSDS service that uses this field independently, so it is excluded from the TM/AOS MC Demultiplexing FR.

7.6.2.1.3 Tables 5-1 of TM SDLP (reference [19]) and AOS SDLP (reference [18]) specify sets of Physical Channel managed parameters. All Physical Channel managed parameters from those Recommended Standards are reflected in the configuration parameters of the TM/AOS MC Demultiplexing FR as defined in the SANA Functional Resources registry, except for the managed parameters identified in table 7-9.

Table 7-9: PC Managed Parameters of the TM and AOS SDLP Recommended Standards That Are Not in the Configuration Parameters of the TM/AOS MC Demultiplexing FR

Excluded Recommended Standard Managed Parameter	Comment
Physical Channel Name	The Physical Channel Name is specified in the xxxPhysChnlName parameters of the Physical Channel Stratum FRs. The TM/AOS MC Demultiplexing FR inherits the value of this parameter from the Physical Channel Stratum FR with which it is associated in the operational configuration.
Transfer Frame Length	The transfer frame length is derived from the tmSyncDecCaduLength and decoding parameters of the Fixed Length Frame Synchronization and Channel Decoding FR instance with which the TM/AOS MC Demux instance is associated.
MC Multiplexing Scheme	Not applicable to the receiving end.
Presence of Frame Header Error Control (AOS only)	As described in 7.6.2.1 NOTE 3 above, the AOS MC Multiplexing FR does not compute or inject Frame Header Error Control octets into the AOS Transfer Frame header.
Presence of Insert Zone and Insert Zone Length	As stated in 7.6.2.1 NOTE 2 above, at the time of this writing, there are no plans to implement a cross-supported Insert service. If the Insert SLE transfer service (or an equivalent CSTS) were ever to be implemented, its functionality would be added to the TM/AOS MC Demultiplexing FR and appropriate configuration parameter(s) added.
Presence of Frame Error Control	The Frame Error Control checking is performed by the Fixed Length Frame Synchronization and Channel Decoding FR instance with which the TM/AOS MC Demux instance is associated.

NOTES

- 1 The configuration parameters of the TM/AOS MC Demultiplexing FR also include parameters that are not explicitly identified as Physical Channel managed parameters in the *TM* and *AOS SDLP* Recommended Standards.
- 2 Figure 7-10 illustrates the sublayers of the TM/AOS MC Demultiplexing FR.

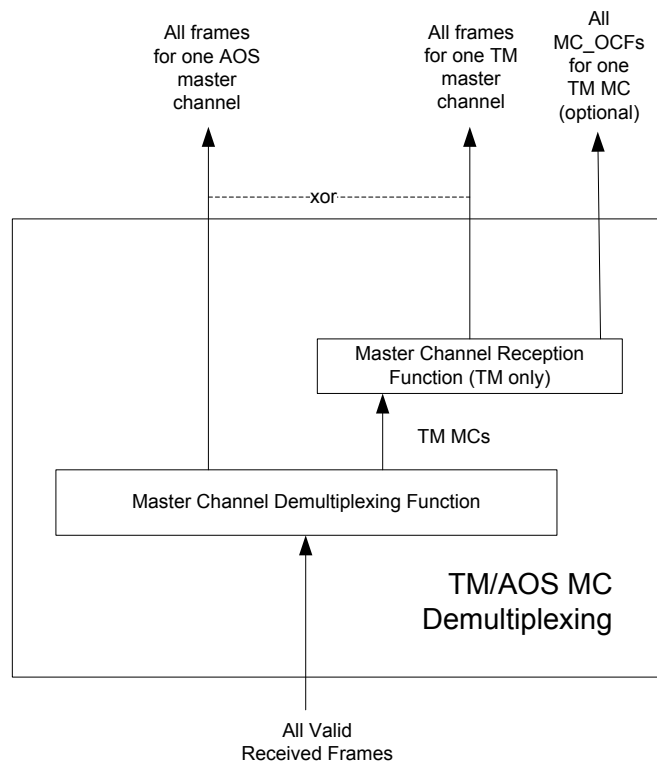

Figure 7-10: Internal Structure of the TM/AOS MC Demultiplexing Functional Resource

7.6.2.2 SAPs and Ancillary Interfaces Used by This Functional Resource

7.6.2.2.1 SAPs Accessed by This Functional Resource

The TM/AOS MC Demultiplexing FR accesses an All Valid Received Frames SAP.

7.6.2.2.2 SAPs Hosted by This Functional Resource

The TM/AOS MC Demultiplexing FR has a Received MC Frames SAP that can be accessed by multiple instances of the TM/AOS VC Demultiplexing FR. Accessors use the MCIDs of the MCF.indication to determine which frames to acquire.

7.6.2.2.3 Ancillary Interfaces Required by This Functional Resource

None.

7.6.2.2.4 Ancillary Interfaces Provided by This Functional Resource

The TM/AOS MC Demultiplexing FR provides a CLCW ancillary interface.

7.6.3 TM/AOS VC DEMULTIPLEXING

7.6.3.1 General

7.6.3.1.1 The FR classifier of the TM/AOS VC Demultiplexing and Reception FR Type is `TmAoSVCdemux`.

7.6.3.1.2 The TM/AOS VC Demultiplexing FR corresponds to:

- a) the VC Demultiplexing functions of TM SDLP;
- b) the VC Demultiplexing functions of AOS SDLP;
- c) the VC-OCF Decommuation subfunction of the VC Reception function of TM SDLP; and
- d) the VC-OCF Decommuation subfunction of the VC Demultiplexing functions of AOS SDLP.

NOTES

- 1 The VC Reception function of TM SDLP also includes Transfer Frame Data Field, Virtual Channel Access SDU (`VCA_SDU`) and VC-FSH Decommuation subfunctions. The Transfer Frame Data Field decommuation function would be performed by another FR in a future version of the TM/AOS Reception FR Set. There is no standard CCSDS service that uses either of the `VCA_SDU` or VC-FSH fields independently, so their decommuation is currently excluded from the TM/AOS Reception FR Set.
- 2 The VC Reception function of AOS SDLP also includes `M_PDU`, `VCA_SDU`, and `Bitstream_PDU` Decommuation subfunctions. The `M_PDU` Field decommuation function would be performed by another FR in a future version of the TM/AOS Reception FR Set. There is no standard CCSDS service that uses either of the `VCA_SDU` or `Bitstream_PDU` fields independently, so their decommuation is currently excluded from the TM/AOS Reception FR Set.

7.6.3.1.3 Table 5-2 of TM SDLP (reference [19]) and AOS SDLP (reference [18]) specify sets of managed parameters for the Master Channel. All Master Channel managed parameters from those Recommended Standards are reflected in the configuration parameters of the TM/AOS Demultiplexing FR as defined in the SANA Functional Resources registry, except for the managed parameters identified in table 7-10.

Table 7-10: MC Managed Parameters of the TM and AOS SDLPs That Are Not in the Configuration Parameters of the TM/AOS VC Demultiplexing FR

Excluded Recommended Standard Managed Parameter	Comment
MC_FSH Length	There is no cross support service that delivers MC-FSH data fields.
Presence of MC_OCF	This is configured and reported through the <code>tmAosMcDemuxClwExtraction</code> parameter of the <code>TmAosMcDemux</code> FR.

NOTES

- 1 The configuration parameters of the TM/AOS VC Demultiplexing FR also include parameters that are not explicitly identified as Master Channel managed parameters in TM and AOS SDLP.
- 2 Figure 7-11 illustrates the sublayers of the TM/AOS VC Demultiplexing FR.

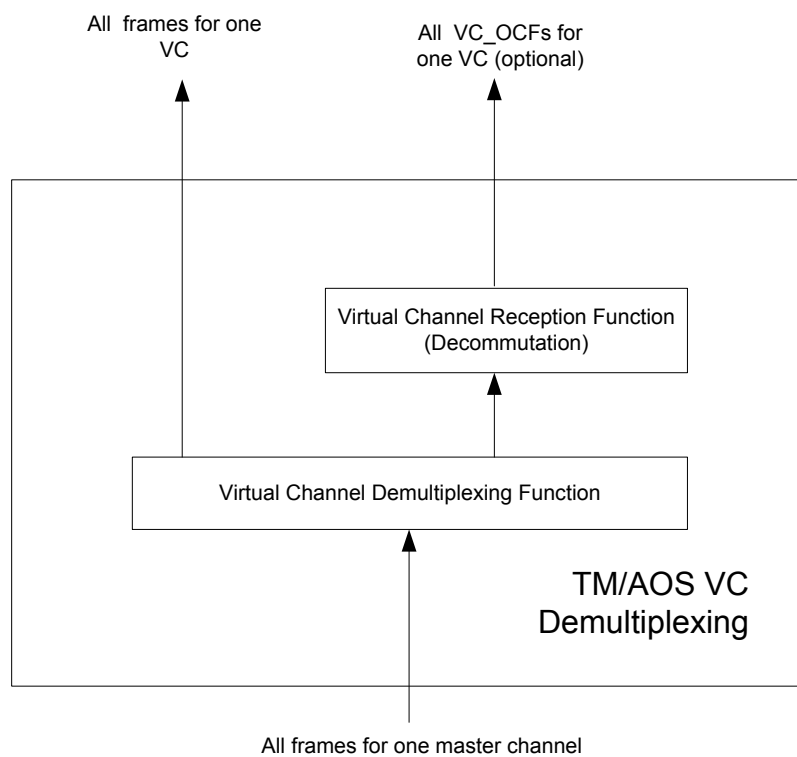

Figure 7-11: Internal Structure of the TM/AOS VC Demultiplexing FR

7.6.3.2 SAPs and Ancillary Interfaces Used by This Functional Resource

7.6.3.2.1 SAPs Accessed by This Functional Resource

The TM/AOS VC Demultiplexing FR accesses a Received MC Frames SAP.

7.6.3.2.2 SAPs Hosted by This Functional Resource

The TM/AOS VC Demultiplexing FR has a Received VC Frames SAP that can be accessed by multiple Accessors. Accessors use the GVCIDs of the VCF.indication to determine which frames to acquire.

7.6.3.2.3 Ancillary Interfaces Required by This Functional Resource

None.

7.6.3.2.4 Ancillary Interfaces Provided by This Functional Resource

The TM/AOS VC Demultiplexing FR provides a CLCW ancillary interface.

7.7 FIXED LENGTH FRAME UNIFIED SPACE DATA LINK PROTOCOL RECEPTION FUNCTIONAL RESOURCE SET OF THE SPACE LINK PROTOCOL FUNCTIONAL RESOURCE STRATUM

7.7.1 OVERVIEW

The FR Types that make up the FLF USLP Reception FR Set of the Space Link Protocol Reception FR Stratum are:

- a) FLF USLP MC Demultiplexing; and
- b) FLF USLP VC Demultiplexing.

NOTE – The All Frames Reception function is formally defined as part of USLP. For fixed-length USLP frames, the All Frames Reception function consists of error detection on the FECF and extraction of Insert SDUs. With respect to error detection on the FECF, this functionality is included in the TM Synchronization and Channel Decoding FR (6.4.2) so that the resultant annotated transfer frames reflect all error detection and/or correction performed on those frames. With respect to extraction of Insert SDUs, there are currently no cross support devices defined for processing or delivering Insert SDUs.

Figure 7-12 illustrates the internal composition of the FLF USLP Space Link Protocol Reception FR Set.

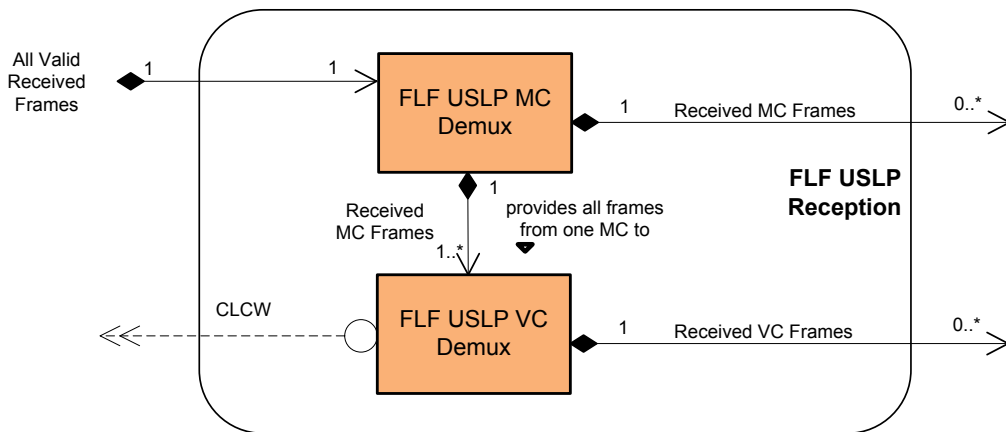

Figure 7-12: Member Functional Resources of the FLF USLP Reception Functional Resource Set

NOTE – The FLF USLP Reception FR Set may be expanded in the future to include FRs that represent the Virtual Channel Reception (and above) functions of the Receiving End of USLP (reference [34]).

7.7.2 FLF USLP MC DEMULTIPLEXING

7.7.2.1 General

7.7.2.1.1 The FR classifier of the FLF USLP MC Demultiplexing FR Type is `FlfUslpMcDemux`.

7.7.2.1.2 The FLF USLP MC Demultiplexing FR corresponds to the MC Demultiplexing function of USLP (reference [34]).

NOTES

- 1 The All Frames Reception function of USLP is defined to perform the FECF decoding function. In the FRM, FECF decoding is performed by the TM Synchronization and Channel Decoding FR.
- 2 The All Frames Reception function of USLP is also the extraction point for Insert SDUs. If the Insert SLE transfer service (or an equivalent CSTS) were ever to be implemented, its functionality would be added to the FLF USLP MC Demultiplexing FR. However, at the time of this writing, there are no plans to implement a cross-supported Insert service.

7.7.2.1.3 Table 5-1 of USLP (reference [34]) specifies a set of managed parameters for the Physical Channel. All Physical Channel managed parameters from that Recommended Standard are reflected in the configuration parameters of the FLF USLP MC Demultiplexing FR as defined in the SANA Functional Resources registry, except for the managed parameters identified in table 7-11.

Table 7-11: PC Managed Parameters of USLP That Are Not in the Configuration Parameters of the FLF USLP MC Demultiplexing FR

Excluded Recommended Standard Managed Parameter	Comment
Physical Channel Name	The Physical Channel Name is specified in the xxxPhysChnlName parameters of the Physical Channel Stratum FRs. The FLF USLP MC Demultiplexing FR inherits the value of this parameter from the Physical Channel Stratum FR with which it is associated in the operational configuration.
Physical Channel Transfer Frame Type	For the FLF USLP MC Demultiplexing FR, the Transfer Frame Type is always 'fixed length' and is not configurable.
Transfer Frame Length	The transfer frame length is derived from the tmSyncDecCaduLength and decoding parameters of the Fixed Length Frame Synchronization and Channel Decoding FR instance with which the FLF USLP MC Demux instance is associated.
MC Multiplexing Scheme (Physical Channel)	Not applicable to the receiving end.
Presence of Insert Zone and Insert Zone Length	As stated in 7.6.2.1 NOTE 2 above, at the time of this writing, there are no plans to implement a cross-supported Insert service. If the Insert SLE transfer service (or an equivalent CSTS) were ever to be implemented, its functionality would be added to the FLF USLP MC Demultiplexing FR and appropriate configuration parameter(s) added.
Generate Only Idle Data Frame	Not applicable to the receiving end.
Maximum Number of Transfer Frames Given to the Coding and Sync Sublayer as a Single Data Unit	This parameter is not applicable to fixed-length frames.
Maximum Value of the Repetitions Parameter to the Coding and Synchronization Sublayer	Repetition of frames to the C&S sublayer is not applicable to fixed-length frames.

NOTE – The configuration parameters of the FLF USLP MC Demultiplexing FR also include parameters that are not explicitly identified as managed parameters in the Recommended Standard.

7.7.2.2 SAPs and Ancillary Interfaces Used by This Functional Resource

7.7.2.2.1 SAPs Accessed by This Functional Resource

The FLF USLP MC Demultiplexing FR accesses an All Valid Received Frames SAP.

7.7.2.2.2 SAPs Hosted by This Functional Resource

The FLF USLP MC Demultiplexing FR has a Received MC Frames SAP that can be accessed by multiple instances of the FLF USLP VC Demultiplexing FR. Accessors use the MCIDs of the MCF.indication to determine which frames to acquire.

7.7.2.2.3 Ancillary Interfaces Required by This Functional Resource

None.

7.7.2.2.4 Ancillary Interfaces Provided by This Functional Resource

None.

7.7.3 FLF USLP VC DEMULTIPLEXING

7.7.3.1 General

7.7.3.1.1 The FR classifier of the FLF USLP VC Demultiplexing and Reception FR Type is `FlfUslpVcDemux`.

7.7.3.1.2 The FLF USLP VC Demultiplexing FR corresponds to:

- a) the fixed-length-frame aspects of the Master Channel Reception function of USLP; and
- b) the fixed-length-frame aspects of the VC Demultiplexing function of USLP.

7.7.3.1.3 Table 5-2 of USLP (reference [34]) specifies a set of managed parameters for the Master Channel. All Master Channel managed parameters from that Recommended Standard are reflected in the configuration parameters of the FLF USLP VC Demultiplexing FR as defined in the SANA Functional Resources registry, except for the managed parameters identified in table 7-12.

Table 7-12: PC Managed Parameters of USLP That Are Not in the Configuration Parameters of the FLF USLP VC Multiplexing FR

Excluded Recommended Standard Managed Parameter	Comment
VC Transfer Frame Type	For the FLF USLP VC Demultiplexing FR, this is always 'fixed length' and not configurable.

NOTES

- 1 The configuration parameters of the FLF USLP VC Demultiplexing FR also include parameters that are not explicitly identified as managed parameters in the Recommended Standard.
- 2 Figure 7-13 illustrates the sublayers of the FLF USLP VC Demultiplexing FR.

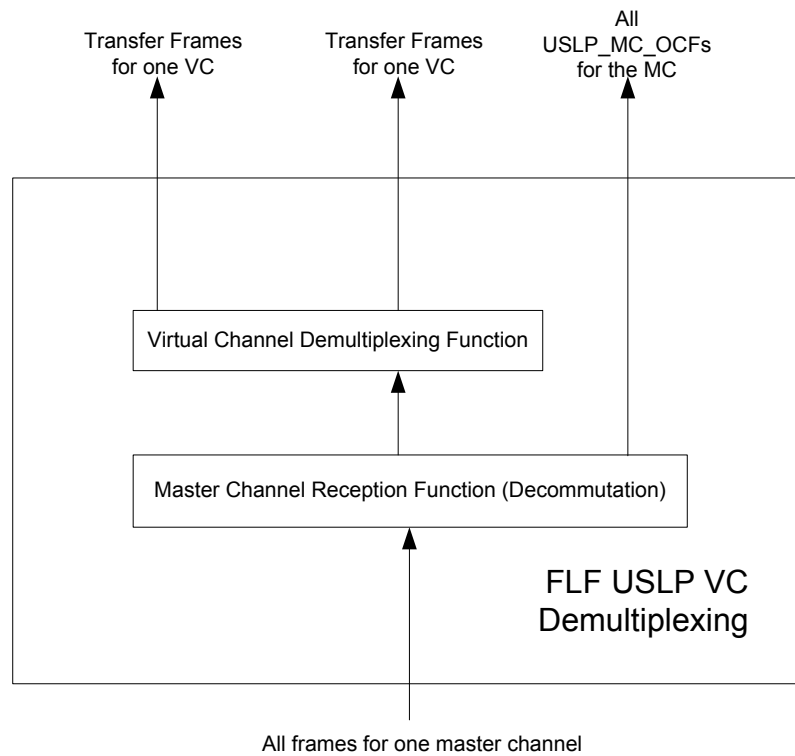

Figure 7-13: Internal Structure of the FLF USLP VC Demultiplexing FR

7.7.3.2 SAPs and Ancillary Interfaces Used by This Functional Resource

7.7.3.2.1 SAPs Accessed by This Functional Resource

The FLF USLP VC Demultiplexing FR accesses a Received MC Frames SAP.

7.7.3.2.2 SAPs Hosted by This Functional Resource

The FLF USLP VC Demultiplexing FR has a Received VC Frames SAP that can be accessed by multiple Accessors. Accessors use the GVCIDs of the VCF.indication to determine which frames to acquire.

7.7.3.2.3 Ancillary Interfaces Required by This Functional Resource

None.

7.7.3.2.4 Ancillary Interfaces Provided by This Functional Resource

The FLF USLP VC Demultiplexing FR provides a CLCW ancillary interface.

8 SLS DATA DELIVERY PRODUCTION FUNCTIONAL RESOURCE STRATUM

8.1 OVERVIEW

The SLS Data Delivery Production FR Stratum is the FR Stratum for FR representing production functions that are (a) associated with Data Delivery Transfer Services and (b) performed during a Space Link Session (i.e., during the execution of an SLS Service Package).

The SLS Data Delivery Production FR Stratum has one FR Set:

- Frame Data Sink FR Set.

8.2 FRAME DATA SINK FUNCTIONAL RESOURCE SET OF THE SLS DATA DELIVERY PRODUCTION FUNCTIONAL RESOURCE STRATUM

8.2.1 OVERVIEW

The Frame Data Sink FR Set of the SLS Data Delivery Production FR Stratum consists of the Frame Data Sink FR. Figure 8-1 illustrates the member FR of the Frame Data Sink FR Set.

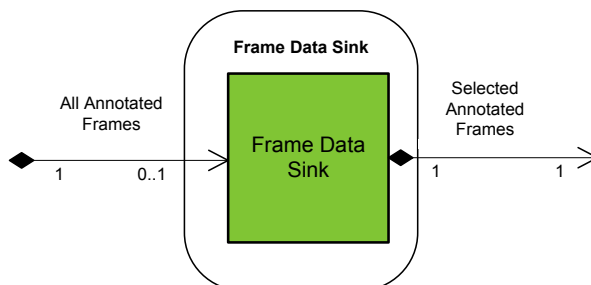

Figure 8-1: Member Functional Resource of the Frame Data Sink Member Functional Resource Set

8.2.2 FRAME DATA SINK

8.2.2.1 General

8.2.2.1.1 The FR classifier of the Frame Data Sink FR Type is `FrameDataSink`.

8.2.2.1.2 The Frame Data Sink FR filters the stream of received annotated transfer frames from a physical channel for subsequent recording in an instance of the Offline Frame Buffer (see 10.2.2). The purpose of this FR is to accommodate data capture policies of Agencies that predetermine which subset of all received frames is recorded for subsequent offline retrieval. Each instance of the Frame Data Sink is tied to (and scheduled as part of) a specific SLS Service Package, whereas the Offline Frame Buffer persists across the execution of multiple SLS Service Packages.

8.2.2.2 SAPs and Ancillary Interfaces Used by This Functional Resource

8.2.2.2.1 SAPs Accessed by This Functional Resource

The Frame Data Sink FR accesses the All Annotated Frames SAP.

8.2.2.2.2 SAPs Hosted by This Functional Resource

The Frame Data Sink FR has a Selected Annotated Frames SAP that can be accessed by a single Accessor.

8.2.2.2.3 Ancillary Interfaces Required by This Functional Resource

None.

8.2.2.2.4 Ancillary Interfaces Provided by This Functional Resource

None.

9 SLS RADIOMETRIC DATA PRODUCTION FUNCTIONAL RESOURCE STRATUM

9.1 OVERVIEW

The SLS Radiometric Data Production FR Stratum has two FR Sets:

- Real-Time Radiometric Data Collection FR Set; and
- Non-Validated Radiometric Data Collection FR Set.

9.2 REAL-TIME RADIOMETRIC DATA COLLECTION FUNCTIONAL RESOURCE SET OF THE SLS RADIOMETRIC DATA PRODUCTION FUNCTIONAL RESOURCE STRATUM

9.2.1 OVERVIEW

The Real-Time Radiometric Data Collection FR Set of the SLS Radiometric Data Production FR Stratum consists of the TDM Segment Generation FR.

Figure 9-1 illustrates the member FR of the Real-Time Radiometric Data Collection FR Set.

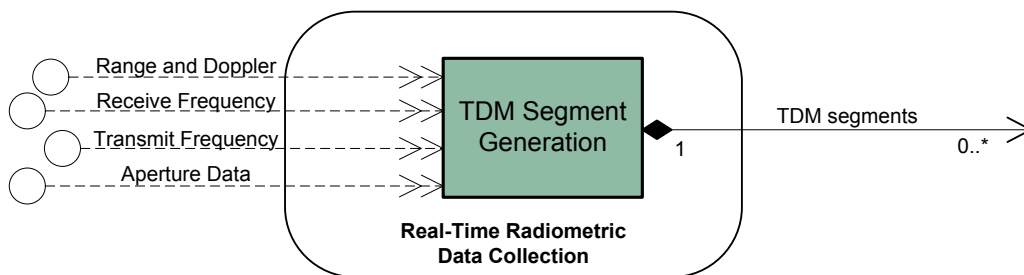

Figure 9-1: Member Functional Resources of the Real-Time Radiometric Data Collection Functional Resource Set

9.2.2 TDM SEGMENT GENERATION

9.2.2.1 General

The FR classifier of the TDM Segment Generation FR Type is `TdmSegmentGen`.

TDM Segment Generation constitutes the production functions associated with collecting:

- a) angle measurements from the aperture;
- b) receive frequency, carrier power, carrier-power-to-noise spectral density, Doppler, range, and ranging-power-to-noise spectral density measurements from the received space link; and

- c) transmit frequency and transmit frequency rate from the transmitted space link, in order to generate TDM segments containing those measurements.

The TDM Segment Generation FR corresponds to the TDM Segment Generation production function specified in annex F2 of the *Cross Support Transfer Services—Tracking Data Service* Recommended Standard (reference [8]). There are no CCSDS Recommended Standards for the TDM Segment Generation function, and in particular, there are no Recommended Standards that define the managed parameters that must be configured to relate the contents of the resulting TDM Atomic Segments to the FRs that produce the data reported in the TDM Atomic Segments. The following description serves as the definition of the function and identifies the configuration parameters by which the FR is configured to perform that function.

9.2.2.2 TDM Segment Generation Function

9.2.2.2.1 General

The purpose of the TDM Segment Generation function is to collect tracking data from the various resources that produce it and create TDM Atomic Segments, as defined in reference [8]. The TDM Generation function can generate 10 kinds of TDM Atomic Segments:

- carrier power;
- carrier-power-to-noise spectral density ratio;
- ranging-power-to-noise spectral density ratio;
- Doppler (instantaneous);
- Doppler (integrated);
- range;
- receive frequency;
- transmit frequency;
- transmit frequency rate; and
- antenna angle pairs.

NOTE – Applicability depends on modulation scheme used (see the *Tracking Data Message* Recommended Standard, reference [36], for definitions of these terms).

In forming each TDM Atomic Segment, the TDM Segment Generation function creates a TDM Metadata Section (see 3.3 of reference [36]) that is appropriate to the data type being reported, followed by a TDM Data Section (see 3.4 of reference [36]) that contains the data being reported. A single TDM Generation function instance can process radiometric data from multiple sources within the ESLT (e.g., multiple transmitters, receivers, and antennas).

Configuration of an instance of the TDM Segment Generation function essentially involves, for each instance of radiometric data to be reported:

- a) identifying the source FR instance (e.g., the Forward 401 Space Link Carrier Transmission instance that supplies transmit frequency measurements); and
- b) associating that source FR instance with the TDM-specific metadata used to identify tracking data measurement types.

NOTE – The following subsections describe the processing performed for each of the 10 supported radiometric data types.

9.2.2.2.2 Carrier Power Atomic Segments

The carrier power (3.5.2.1 of reference [36]) conveys the strength of the radio signal transmitted by the Space User Node as received at the ESLT.¹

Carrier power is reported by a return space link FR within the Physical Channel FR Stratum. The information necessary to configure a Carrier Power path is as follows:

- a) The name of the ESLT aperture that is used by the receiving FR instance. This name appears in the PARTICIPANT_1 metadata keyword of the Metadata Sections of the TDM Atomic Segments generated for a Carrier Power path. The name shall be the name assigned to the aperture in the SANA Service Sites and Apertures registry (reference [33]).
- b) The name of the Space User Node that transmits the signal being measured. This name appears in the PARTICIPANT_2 metadata keyword of the Metadata Sections of the TDM Atomic Segments generated for a Carrier Power path. If the Space User Node has a single transponder or transmitter that can be used in the generation of radiometric measurements, then the Space User Node name shall be the abbreviated name specified in the SANA Spacecraft registry (reference [35]). If the Space User Node has multiple transponders or transmitters, the Space User Node name is that of the transponder/transmitter that is the source of the carrier signal. The name of the transponder/transmitter shall be formed by the concatenation of the SANA Spacecraft registry abbreviated name and the frequency band in which the transponder/transmitter operates: <Space User Node Name>-<frequency band>, where <frequency band> is the SANA Frequency Band Designator specified in table 2-1 of reference [26].

¹ This definition is a paraphrase of the TDM (reference [36]) definition of carrier power, adjusted for the context of the ESLT and cross support services terminology.

NOTE – For example, if the Space User Node with the SANA Spacecraft registry abbreviated name ‘EXOSAT’ has a single transponder or transmitter that can be used in the generation of radiometric measurements, then the User Space Node name is ‘EXOSAT’. However, if EXOSAT has multiple transponders/transmitters in different frequency bands that can be used simultaneously (one of which is near-Earth X-band), then the User Space Node name for the X-band transponder/transmitter is ‘EXOSAT-X-NE’, where the ‘X-NE’ is the SANA Frequency Band Designator for near-Earth X-band.

- c) The reporting period at which the Carrier Power Atomic Segments are to be generated, in seconds.

NOTE – An ESLT implementation may have this value fixed by the implementation. In such a case, the value of this parameter is constrained to be the value that is supported by the implementation. Also, an ESLT implementation may generate Carrier Power measurements on a non-periodic basis. In such a case, the reporting period configuration parameter of the TDM Segment Generation instance is set to zero.

- d) The frequency band of the carrier signal received from the Space User Node, using the SANA Frequency Band Designator specified in table 2-1 of reference [26].
- e) The FR Name of the Physical Channel FR that receives the carrier (and therefore has the Receive Frequency provided interface for that carrier power data).

Figure 9-2 specifies the contents of the Carrier Power Atomic Segment generated by the TDM Segment Generation function.

META_START	
TIME_SYSTEM	= UTC
START_TIME	= <time that the carrier power is sampled>
STOP_TIME	= <time that the carrier power is sampled>
PARTICIPANT_1	= <name of the ESLT aperture>
PARTICIPANT_2	= <name of the Space User Node[-<frequency band>]>
MODE	= SEQUENTIAL
PATH	= 2,1
RECEIVE_BAND	= <frequency band>
META_STOP	
DATA_START	
CARRIER_POWER	= <received carrier power in dBW>
DATA_STOP	

Figure 9-2: Contents of the Carrier Power Atomic Segment

9.2.2.2.3 Carrier-Power-to-Noise Spectral Density Ratio Atomic Segments

Carrier-power-to-noise spectral density ratio (P_c/N_o) (3.5.2.5 of reference [36]) is reported by a return space link FR within the Physical Channel FR Stratum.

When the carrier being reported upon uses a suppressed carrier modulation scheme, the value reported as P_c/N_o shall be the *reconstructed* carrier-power-to-noise density ratio.

The information necessary to configure a P_c/N_o path is as follows:

- a) The name of the ESLT aperture that is used by the receiving FR instance. This name appears in the PARTICIPANT_1 metadata keyword of the Metadata Sections of the TDM Atomic Segments generated for a P_c/N_o path. The name shall be the name assigned to the aperture in the SANA Service Sites and Apertures registry (reference [33]).
- b) The name of the Space User Node that transmits the signal being measured. This name appears in the PARTICIPANT_2 metadata keyword of the Metadata Sections of the TDM Atomic Segments generated for a P_c/N_o path. If the Space User Node has a single transponder or transmitter that can be used in the generation of radiometric measurements, then the Space User Node name shall be the abbreviated name specified in the SANA Spacecraft registry (reference [35]). If the Space User Node has multiple transponders or transmitters, the Space User Node name is that of the transponder/transmitter that is the source of the carrier signal. The name of the transponder/transmitter shall be formed by the concatenation of the SANA Spacecraft registry abbreviated name and the frequency band in which the transponder/transmitter operates: <Space User Node Name>-<frequency band>, where <frequency band> is the SANA Frequency Band Designator specified in table 2-1 of reference [26]. (See the NOTE under 9.2.2.2.2 b.)
- c) The reporting period at which the P_c/N_o Atomic Segments are to be generated, in seconds.

NOTE – An ESLT implementation may have this value fixed by the implementation. In such a case, the value of this parameter is constrained to be the value that is supported by the implementation. Also, an ESLT implementation may generate P_c/N_o measurements on a non-periodic basis. In such a case, the reporting period configuration parameter of the TDM Segment Generation instance is set to zero.

- d) The frequency band of the carrier signal received from the Space User Node, using the SANA Frequency Band Designator specified in table 2-1 of reference [26].
- e) The FR Name of the Physical Channel FR that receives the carrier (and therefore has the Receive Frequency provided interface for that P_c/N_o data).

Figure 9-3 specifies the contents of the P_c/N_o Atomic Segment generated by the TDM Segment Generation function.

META_START	
TIME_SYSTEM	= UTC
START_TIME	= <time that the Pc/No is sampled>
STOP_TIME	= <time that the Pc/No is sampled>
PARTICIPANT_1	= <name of the ESLT aperture>
PARTICIPANT_2	= <name of the Space User Node[-<frequency band>]>
MODE	= SEQUENTIAL
PATH	= 2,1
RECEIVE_BAND	= <frequency band>
META_STOP	
DATA_START	
PC_NO	= <Pc/No in dBHz>
DATA_STOP	

Figure 9-3: Contents of the Pc/No Atomic Segment

9.2.2.2.4 Ranging-Power-to-Noise Spectral Density Ratio (Pr/No) Atomic Segments

Ranging-power-to-noise spectral density ratio (Pr/No) (3.5.2.6 of reference [36]) is reported by a return space link FR within the Physical Channel FR Stratum.

When the carrier being reported upon uses a Gaussian Minimum Shift Keying (GMSK) modulation scheme, the value reported as Pc/No shall be the ranging *tone* power to noise spectral density ratio.

The information necessary to configure a Pr/No path is as follows:

- a) The name of the ESLT aperture that is used by the receiving FR instance. This name appears in the PARTICIPANT_1 metadata keyword of the Metadata Sections of the TDM Atomic Segments generated for a Pr/No path. The name shall be the name assigned to the ESLT in the SANA Service Sites and Apertures registry (reference [33]).
- b) The name of the Space User Node that transmits the signal being measured. This name appears in the PARTICIPANT_2 metadata keyword of the Metadata Sections of the TDM Atomic Segments generated for a Pr/No path. If the Space User Node has a single transponder or transmitter that can be used in the generation of radiometric measurements, then the Space User Node name shall be the abbreviated name specified in the SANA Spacecraft registry (reference [35]). If the Space User Node has multiple transponders or transmitters, the Space User Node name is that of the transponder/transmitter that is the source of the carrier signal. The name of the transponder/transmitter is formed by the concatenation of the SANA Spacecraft registry abbreviated name and the frequency band in which the transponder/transmitter operates: <Space User Node Name>-<frequency band>, where <frequency band> is the SANA Frequency Band Designator specified in table 2-1 of reference [26]. (See the NOTE under 9.2.2.2.2 b).)

- c) The reporting period at which the Pr/No Atomic Segments are to be generated, in seconds.

NOTE – An ESLT implementation may have this value fixed by the implementation. In such a case, the value of this parameter is constrained to be the value that is supported by the implementation. Also, an ESLT implementation may generate Pr/No measurements on a non-periodic basis. In such a case, the reporting period configuration parameter of the TDM Segment Generation instance is set to zero.

- d) The frequency band of the carrier signal received from the Space User Node, using the SANA Frequency Band Designator specified in table 2-1 of reference [26].
- e) The FR Name of the Physical Channel FR that generates the Pr/No measurements (and therefore has the Range and Doppler provided interface for that Pr/No data).

Figure 9-4 specifies the contents of the Pr/No Atomic Segment generated by the TDM Segment Generation function.

META_START	
TIME_SYSTEM	= UTC
START_TIME	= <time that the Pr/No is sampled>
STOP_TIME	= <time that the Pr/No is sampled>
PARTICIPANT_1	= <name of the ESLT aperture>
PARTICIPANT_2	= <name of the Space User Node[-<frequency band>]>
MODE	= SEQUENTIAL
PATH	= 2,1
RECEIVE_BAND	= <frequency band>
META_STOP	
DATA_START	
PR_NO	= <Pr/No in dBHz>
DATA_STOP	

Figure 9-4: Contents of the Pr/No Atomic Segment

9.2.2.2.5 Doppler (Instantaneous) Atomic Segments

Doppler (instantaneous) “represents the instantaneous range rate of the spacecraft” (3.5.2.2 of reference [36]). Doppler measurements are reported by an FR within the Physical Channel FR Stratum that provides Doppler measurements.

The TDM Segment Generation function is limited to generating TDM Atomic Segments that contain data measurements that are available locally within the ESLT. With respect to Doppler measurements, this means that only the following Doppler measurements are

reported by the TD-CSTS: one-way, two-way, and three-way when both apertures are associated with the same ESLT.

NOTE – TDMs containing three-way Doppler measurements involving multiple ESLTs may be generated by a facility that has access to the information from all of the participating ESLTs. Some of the contributing information may be reported by an ESLT via the TD-CSTS. For example, if ESLT X has the aperture that transmits the forward leg of the three-way link, that ESLT can provide Transmit Frequency Atomic Segments (see 9.2.2.2.9) to a facility that integrates the source data into the three-way TDMs. If ESLT Y receives the last leg of the three-way link, it can provide Receive Frequency Atomic Segments (see 9.2.2.2.8) and (one-way) Doppler Atomic Segments to the facility that integrates the source data into the three-way TDMs.

The information necessary to configure a Doppler (instantaneous) path is as follows:

- a) The name of the ESLT aperture that (1) receives the signal (for one-way Doppler measurements), (2) transmits and receives the signal (for two-way Doppler measurements), or (3) transmits the signal (for three-way Doppler measurements when the receiving aperture is part of the same ESLT). This name appears in the PARTICIPANT_1 metadata keyword of the Metadata Sections of the TDM Atomic Segments generated for a Doppler (instantaneous) path. The name shall be the name assigned to the aperture in the SANA Service Sites and Apertures registry (reference [33]).
- b) The name of the Space User Node that transmits the signal being received by the ESLT. This name appears in the PARTICIPANT_2 metadata keyword of the Metadata Sections of the TDM Atomic Segments generated for a Doppler (instantaneous) path. If the Space User Node has a single transponder or transmitter that can be used in the generation of radiometric measurements, then the Space User Node name shall be the abbreviated name specified in the SANA Spacecraft registry (reference [35]). If the Space User Node has multiple transponders or transmitters, the Space User Node name is that of the transponder/transmitter that is the source of the carrier signal. The name of the transponder/transmitter shall be formed by the concatenation of the SANA Spacecraft registry abbreviated name and the frequency band in which the transponder/transmitter operates: <Space User Node Name>-<frequency band>, where <frequency band> is the SANA Frequency Band Designator specified in table 2-1 of reference [26]. (See the NOTE under 9.2.2.2.2 b.)
- c) If three-way Doppler measurements are taken with both transmitting and receiving apertures associated with the ESLT, the name of the ESLT aperture that receives the signal. This name appears in the PARTICIPANT_3 metadata keyword of the Metadata Sections of the TDM Atomic Segments generated for a Doppler (instantaneous) path. The name shall be the name assigned to the aperture in the SANA Service Sites and Apertures registry (reference [33]).
- d) The reporting period at which the Doppler (instantaneous) Atomic Segments are to be generated, in seconds.

NOTE – An ESLT implementation may have this value fixed by the implementation. In such a case, the value of this parameter is constrained to be the value that is supported by the implementation.

- e) The frequency band of the carrier signal transmitted to the Space User Node, using the SANA Frequency Band Designator specified in table 2-1 of reference [26]. This value is not used for one-way Doppler measurements.

NOTE – Whether the Doppler measurements are one-way, two-way, or three-way is determined by the configuration of the Doppler-measuring FR that provides the Doppler measurements.

- f) The frequency band of the carrier signal received from the Space User Node, using the SANA Frequency Band Designator specified in table 2-1 of reference [26].
- g) The FR Name of the Physical Channel FR that generates the Doppler measurements (and therefore has the Range and Doppler provided interface for that Doppler data).

Figure 9-5 specifies the contents of the one-way Doppler (instantaneous) Atomic Segment generated by the TDM Segment Generation function.

META_START	
TIME_SYSTEM	= UTC
START_TIME	= <time that the Doppler is sampled>
STOP_TIME	= <time that the Doppler is sampled>
PARTICIPANT_1	= <name of the ESLT aperture>
PARTICIPANT_2	= <name of the Space User Node[-<frequency band>]>
MODE	= SEQUENTIAL
PATH	= 2,1
RECEIVE_BAND	= <receive frequency band>
META_STOP	
DATA_START	
DOPPLER_INSTANTANEOUS	= <Doppler in km/sec>
RECEIVE_FREQ	= <receive frequency in Hz>
DATA_STOP	

Figure 9-5: Contents of the One-Way Doppler (Instantaneous) Atomic Segment

Figure 9-6 specifies the contents of the two-way Doppler (instantaneous) Atomic Segment generated by the TDM Segment Generation function.

META_START	
TIME_SYSTEM	= UTC
START_TIME	= <time that the Doppler is sampled>
STOP_TIME	= <time that the Doppler is sampled>
PARTICIPANT_1	= <name of the ESLT aperture>
PARTICIPANT_2	= <name of the Space User Node[-<frequency band>]>
MODE	= SEQUENTIAL
PATH	= 1,2,1
TRANSMIT_BAND	= <transmit frequency band>
RECEIVE_BAND	= <receive frequency band>
TURNAROUND_NUMERATOR	= <turnaround numerator>*
TURNAROUND_DENOMINATOR	= <turnaround denominator>*
META_STOP	
DATA_START	
DOPPLER_INSTANTANEOUS	= <Doppler in km/sec>
TRANSMIT_FREQ_1	= <transmit frequency in Hz>
RECEIVE_FREQ	= <receive frequency in Hz>
DATA_STOP	

* The turnaround numerator and denominator (see TURNAROUND_NUMERATOR and TURNAROUND_DENOMINATOR in table 3-3 of reference [36]) are determined by the frequency band of the transmitted carrier to which the received carrier is coherently related. For CCSDS 401.0-conformant carriers, the turnaround ratios are specified in reference [23]. For CCSDS 415.1-conformant carriers, the turnaround ratio is specified in reference [25]. The TDM Segment Generation FR obtains this information through the relationship identified by the Range and Doppler interface with an FR of the receiving carrier's FR Set.

Figure 9-6: Contents of the Two-Way Doppler (Instantaneous) Atomic Segment

Figure 9-7 specifies the contents of the three-way Doppler (instantaneous) Atomic Segment generated by the TDM Segment Generation function, when both the transmitting and receiving apertures are associated with the ESLT.

META_START	
TIME_SYSTEM	= UTC
START_TIME	= <time that the Doppler is sampled>
STOP_TIME	= <time that the Doppler is sampled>
PARTICIPANT_1	= <name of the transmitting aperture at the ESLT>
PARTICIPANT_2	= <name of the Space User Node[-<frequency band>]>
PARTICIPANT_3	= <name of the receiving aperture at the ESLT>
MODE	= SEQUENTIAL
PATH	= 1,2,3
TRANSMIT_BAND	= <transmit frequency band>
RECEIVE_BAND	= <receive frequency band>
TURNAROUND_NUMERATOR	= <turnaround numerator>*
TURNAROUND_DENOMINATOR	= <turnaround denominator>*
META_STOP	
DATA_START	
DOPPLER_INSTANTANEOUS	= <Doppler in km/sec>
TRANSMIT_FREQ_1	= <transmit frequency in Hz>
RECEIVE_FREQ	= <receive frequency in Hz>
DATA_STOP	

* The turnaround numerator and denominator (see TURNAROUND_NUMERATOR and TURNAROUND_DENOMINATOR in table 3-3 of reference [36]) are determined by the frequency band of the transmitted carrier to which the received carrier is coherently related. For CCSDS 401.0-conformant carriers, the turnaround ratios are specified in reference [23]. For CCSDS 415.1-conformant carriers, the turnaround ratio is specified in reference [25]. The TDM Segment Generation FR obtains this information through the relationship identified by the Range and Doppler interface with an FR of the receiving carrier's FR Set.

Figure 9-7: Contents of the Three-Way Doppler (Instantaneous) Atomic Segment

9.2.2.2.6 Doppler (Integrated) Atomic Segments

Doppler (integrated) “represents the mean range rate of the spacecraft over the INTEGRATION_INTERVAL specified in the Metadata Section” (3.5.2.3 of reference [36]). Doppler measurements are reported by an FR within the Physical Channel FR Stratum that provides Doppler measurements.

The TDM Segment Generation function is limited to generating TDM Atomic Segments that contain data measurements that are available locally within the ESLT. With respect to Doppler measurements, this means that only the following Doppler measurements are reported by the TD-CSTS: one-way, two-way, and three-way when both apertures are associated with the same ESLT.

NOTE – TDMs containing three-way Doppler measurements involving multiple ESLTs may be generated by a facility that has access to the information from all of the participating ESLTs. Some of the contributing information may be reported by an ESLT via the TD-CSTS. For example, if ESLT X has the aperture that transmits the forward leg of the three-way link, that ESLT can provide Transmit Frequency Atomic Segments (see 9.2.2.2.9) to a facility that integrates the source data into the three-way TDMs. If ESLT Y receives the last leg of the three-way link, it can provide Receive Frequency Atomic Segments (see 9.2.2.2.8) and (one-way) Doppler Atomic Segments to the facility that integrates the source data into the three-way TDMs.

The information necessary to configure a Doppler (integrated) path is as follows:

- a) The name of the ESLT aperture that (1) receives the signal (for one-way Doppler measurements), (2) transmits and receives the signal (for two-way Doppler measurements), or (3) transmits the signal (for three-way Doppler measurements when the receiving aperture is part of the same ESLT). This name appears in the PARTICIPANT_1 metadata keyword of the Metadata Sections of the TDM Atomic Segments generated for a Doppler (integrated) path. The name shall be the name assigned to the aperture in the SANA Service Sites and Apertures registry (reference [33]).
- b) The name of the Space User Node that transmits the signal being received by the ESLT. This name appears in the PARTICIPANT_2 metadata keyword of the Metadata Sections of the TDM Atomic Segments generated for a Doppler (integrated) path. If the Space User Node has a single transponder or transmitter that can be used in the generation of radiometric measurements, then the Space User Node name shall be the abbreviated name specified in the SANA Spacecraft registry (reference [35]). If the Space User Node has multiple transponders or transmitters, the Space User Node name is that of the transponder/transmitter that is the source of the carrier signal. The name of the transponder/transmitter shall be formed by the concatenation of the SANA Spacecraft registry abbreviated name and the frequency band in which the transponder/transmitter operates: <Space User Node Name>-<frequency band>, where <frequency band> is the SANA Frequency Band Designator specified in table 2-1 of reference [26]. (See the NOTE under 9.2.2.2.2 b.)
- c) If three-way Doppler measurements are taken with both transmitting and receiving apertures associated with the ESLT, the name of the ESLT aperture that receives the signal. This name appears in the PARTICIPANTS_3 metadata keyword of the Metadata Sections of the TDM Atomic Segments generated for a Doppler (instantaneous) path. The name shall be the name assigned to the aperture in the SANA Service Sites and Apertures registry (reference [33]).
- d) The integration interval over which the Doppler measurements are to be integrated, in seconds. (See INTEGRATION_INTERVAL in table 3-3 of reference [36].)

NOTE – An ESLT implementation may have this value fixed by the implementation. In such a case, the value of this parameter is constrained to be the value that is supported by the implementation.

- e) The integration reference, which specifies “the relationship between the INTEGRATION_INTERVAL and the timetag on the data, i.e., whether the timetag represents the start, middle, or end of the integration period.” (See INTEGRATION_REF in table 3-3 of reference [36].)
- f) The reporting period at which the Doppler (integrated) Atomic Segments are to be generated, in seconds.

NOTE – An ESLT implementation may have this value fixed by the implementation. In such a case, the value of this parameter is constrained to be the value that is supported by the implementation.

- g) The frequency band of the carrier signal transmitted to the Space User Node, using the SANA Frequency Band Designator specified in table 2-1 of reference [26]. This value is not used for one-way Doppler measurements.

NOTE – Whether the Doppler measurements are one-way, two-way, or three-way is determined by the configuration of the Doppler-measuring FR that provides the Doppler measurements.

- h) The frequency band of the carrier signal received from the Space User Node, using the SANA Frequency Band Designator specified in table 2-1 of reference [26].
- i) The FR Name of the Physical Channel FR that generates the Doppler measurements (and therefore has the Range and Doppler provided interface for that Doppler data).

Figure 9-8 specifies the contents of the one-way Doppler (integrated) Atomic Segment generated by the TDM Segment Generation function.

META_START	
TIME_SYSTEM	= UTC
START_TIME	= <time of the Doppler (integrated) measurement>
STOPTIME	= <time of the Doppler (integrated) measurement>
PARTICIPANT_1	= <name of the ESLT aperture>
PARTICIPANT_2	= <name of the Space User Node[-<frequency band>]>
MODE	= SEQUENTIAL
PATH	= 2,1
RECEIVE_BAND	= <receive frequency band>
INTEGRATION_INTERVAL	= <integration interval in sec>
INTEGRATION_REF	= 'START', 'MIDDLE', or 'END'
META_STOP	
DATA_START	
DOPPLER_INTEGRATED	= <Doppler in km/sec>
RECEIVE_FREQ	= <receive frequency in Hz>
DATA_STOP	

Figure 9-8: Contents of the One-Way Doppler (Integrated) Atomic Segment

Figure 9-9 specifies the contents of the two-way Doppler (integrated) Atomic Segment generated by the TDM Segment Generation function.

META_START	
TIME_SYSTEM	= UTC
START_TIME	= <time of the Doppler (integrated) measurement>
STOPTIME	= <time of the Doppler (integrated) measurement>
PARTICIPANT_1	= <name of the ESLT aperture>
PARTICIPANT_2	= <name of the Space User Node[-<frequency band>]>
MODE	= SEQUENTIAL
PATH	= 1,2,1
TRANSMIT_BAND	= <transmit frequency band>
RECEIVE_BAND	= <receive frequency band>
TURNAROUND_NUMERATOR	= <turnaround numerator>*
TURNAROUND_DENOMINATOR	= <turnaround denominator>*
INTEGRATION_INTERVAL	= <integration interval in sec>
INTEGRATION_REF	= <'START', 'MIDDLE', or 'END'>
META_STOP	
DATA_START	
DOPPLER_INTEGRATED	= <Doppler in km/sec>
TRANSMIT_FREQ_1	= <transmit frequency in Hz>
RECEIVE_FREQ	= <receive frequency in Hz>
DATA_STOP	

*The turnaround numerator and denominator (see TURNAROUND_NUMERATOR and TURNAROUND_DENOMINATOR in table 3-3 of reference [36]) are determined by the frequency band of the transmitted carrier to which the received carrier is coherently related. For CCSDS 401.0-conformant carriers, the turnaround ratios are specified in reference [23]. For CCSDS 415.1-conformant carriers, the turnaround ratio is specified in reference [25]. The TDM Segment Generation FR obtains this information through the relationship identified by the Range and Doppler interface with an FR of the receiving carrier's FR Set.

Figure 9-9: Contents of the Two-Way Doppler (Integrated) Atomic Segment

Figure 9-10 specifies the contents of the three-way Doppler (integrated) Atomic Segment generated by the TDM Segment Generation function, when both the transmitting and receiving apertures are associated with the ESLT.

META_START	
TIME_SYSTEM	= UTC
START_TIME	= <time of the Doppler (integrated) measurement>
STOPTIME	= <time of the Doppler (integrated) measurement>
PARTICIPANT_1	= <name of the transmitting aperture at the ESLT>
PARTICIPANT_2	= <name of the Space User Node[-<frequency band>]>
PARTICIPANT_3	= <name of the receiving aperture at the ESLT>
MODE	= SEQUENTIAL
PATH	= 1,2,3
TRANSMIT_BAND	= <transmit frequency band>
RECEIVE_BAND	= <receive frequency band>
TURNAROUND_NUMERATOR	= <turnaround numerator>*
TURNAROUND_DENOMINATOR	= <turnaround denominator>*
INTEGRATION_INTERVAL	= <integration interval in sec>
INTEGRATION_REF	= <'START', 'MIDDLE', or 'END'>
META_STOP	
DATA_START	
DOPPLER_INTEGRATED	= <Doppler in km/sec>
TRANSMIT_FREQ_1	= <transmit frequency in Hz>
RECEIVE_FREQ	= <receive frequency in Hz>
DATA_STOP	

*The turnaround numerator and denominator (see TURNAROUND_NUMERATOR and TURNAROUND_DENOMINATOR in table 3-3 of reference [36]) are determined by the frequency band of the transmitted carrier to which the received carrier is coherently related. For CCSDS 401.0-conformant carriers, the turnaround ratios are specified in reference [23]. For CCSDS 415.1-conformant carriers, the turnaround ratio is specified in reference [25]. The TDM Segment Generation FR obtains this information through the relationship identified by the Range and Doppler interface with an FR of the receiving carrier's FR Set.

Figure 9-10: Contents of the Three-Way Doppler (Integrated) Atomic Segment

9.2.2.2.7 Range Atomic Segments

Range measurements are reported by an FR within the Physical Channel FR Stratum that provides range-measurements.

The information necessary to configure a range path is as follows:

- a) The name of the ESLT aperture that transmits and receives the ranging signal (for two-way Doppler measurements) or transmits the signal (for three-way Doppler measurements when the receiving aperture is part of the same ESLT). This name appears in the PARTICIPANT_1 metadata keyword of the Metadata Sections of the TDM Atomic Segments generated for a range path. The name shall be the name assigned to the ESLT in the SANA Service Sites and Apertures registry (reference [33]).

- b) The name of the Space User Node that transmits the signal being measured. This name appears in the PARTICIPANT_2 metadata keyword of the Metadata Sections of the TDM Atomic Segments generated for a range path. If the Space User Node has multiple transponders or transmitters, the Space User Node name is that of the transponder/transmitter that is the source of the carrier signal. The name of the transponder/transmitter shall be formed by the concatenation of the SANA Spacecraft registry abbreviated name and the frequency band in which the transponder/transmitter operates: <Space User Node Name>-<frequency band>, where <frequency band> is the SANA Frequency Band Designator specified in table 2-1 of reference [26]. (See the NOTE under 9.2.2.2.2 b.)
- c) If three-way Doppler measurements are taken with both transmitting and receiving apertures associated with the ESLT, the name of the ESLT aperture that receives the signal. This name appears in the PARTICIPANT_3 metadata keyword of the Metadata Sections of the TDM Atomic Segments generated for a Doppler (instantaneous) path. The name shall be the name assigned to the aperture in the SANA Service Sites and Apertures registry (reference [33]).
- d) The range units (see RANGE_UNITS in table 3-3 of reference [36]). The values are 'km' or 's'.

NOTE – An ESLT implementation may have this value fixed by the implementation. In such a case, the value of this parameter is constrained to be the value that is supported by the implementation.
- e) The integration interval over which the Range measurements are to be integrated, in seconds.

NOTE – The INTEGRATION_INTERVAL is not mandatory (but is optional) for range data, but no explanation is provided in reference [36]) of when it is or is not used.
- f) The integration reference, which specifies “the relationship between the INTEGRATION_INTERVAL and the timetag on the data, i.e., whether the timetag represents the start, middle, or end of the integration period.” (See INTEGRATION_REF in table 3-3 of reference [36].)
- g) The frequency band of the carrier signal transmitted to the Space User Node, using the SANA Frequency Band Designator specified in table 2-1 of reference [26].
- h) The frequency band of the carrier signal received from the Space User Node, using the SANA Frequency Band Designator specified in table 2-1 of reference [26].
- i) The FR Name of the Physical Channel FR that generates the range measurements (and therefore has the Range and Doppler provided interface for that range data).

Figure 9-11 specifies the contents of the two-way Range Atomic Segment generated by the TDM Segment Generation function.

META_START	
TIME_SYSTEM	= UTC
START_TIME	= <time of the range measurement>
STOP_TIME	= <time of the range measurement>
PARTICIPANT_1	= <name of the ESLT aperture>
PARTICIPANT_2	= <name of the Space User Node[-<frequency band>]>
MODE	= SEQUENTIAL
PATH	= 1,2,1
RANGE_MODE	= 'COHERENT' or 'CONSTANT' *
RANGE_MODULUS	= <modulus of the range observable>**
RANGE_UNITS	= 'km' or 's'
TRANSMIT_BAND	= <transmit frequency band>
RECEIVE_BAND	= <receive frequency band>
TURNAROUND_NUMERATOR	= <turnaround numerator>***
TURNAROUND_DENOMINATOR	= <turnaround denominator>***
INTEGRATION_REF	= 'START', 'MIDDLE', or 'END'
META_STOP	
DATA_START	
RANGE	= <range in RANGE_UNITS>
DATA_STOP	

* The range mode (see RANGE_MODE in table 3-3 of reference [36]) is a characteristic of the type of ranging performed by of the FR that generates the range measurements. The TDM Segment Generation FR obtains this information through the relationship established by the Range and Doppler interface with that FR.

**The determination of the range modulus (see RANGE_MODULUS in table 3-3 of reference [36]) depends on a priori knowledge of the spacecraft trajectory. The TDM Segment Generation FR obtains this information through the relationship established by the Range and Doppler interface with that FR.

*** The turnaround numerator and denominator (see TURNAROUND_NUMERATOR and TURNAROUND_DENOMINATOR in table 3-3 of reference [36]) are determined by the frequency band of the transmitted carrier to which the received carrier is coherently related. For CCSDS 401.0-conformant carriers, the turnaround ratios are specified in reference [23]. For CCSDS 415.1-conformant carriers, the turnaround ratio is specified in reference [25]. The TDM Segment Generation FR obtains this information through the relationship identified by the Range and Doppler interface with an FR of the receiving carrier's FR Set.

Figure 9-11: Contents of the Two-Way Range Atomic Segment

Figure 9-12 specifies the contents of the three-way Range Atomic Segment generated by the TDM Segment Generation function, when both the transmitting and receiving apertures are associated with the ESLT.

META_START	
TIME_SYSTEM	= UTC
START_TIME	= <time of the range measurement>
STOP_TIME	= <time of the range measurement>
PARTICIPANT_1	= <name of the transmitting aperture at the ESLT>
PARTICIPANT_2	= <name of the Space User Node[-<frequency band>]>
PARTICIPANT_3	= <name of the receiving aperture at the ESLT>
MODE	= SEQUENTIAL
PATH	= 1,2,3
RANGE_MODE	= 'COHERENT' or 'CONSTANT' *
RANGE_MODULUS	= <modulus of the range observable>**
RANGE_UNITS	= 'km' or 's'
TRANSMIT_BAND	= <transmit frequency band>
RECEIVE_BAND	= <receive frequency band>
TURNAROUND_NUMERATOR	= <turnaround numerator>***
TURNAROUND_DENOMINATOR	= <turnaround denominator>***
INTEGRATION_REF	= 'START', 'MIDDLE', or 'END'
META_STOP	
DATA_START	
RANGE	= <range in RANGE_UNITS>
DATA_STOP	

* The range mode (see RANGE_MODE in table 3-3 of reference [36]) is a characteristic of type of ranging performed by the FR that generates the range measurements. The TDM Segment Generation FR obtains this information through the relationship established by the Range and Doppler interface with that FR.

**The determination of the range modulus (see RANGE_MODULUS in table 3-3 of reference [36]) depends on a priori knowledge of the spacecraft trajectory. The TDM Segment Generation FR obtains this information through the relationship established by the Range and Doppler interface with that FR.

*** The turnaround numerator and denominator (see TURNAROUND_NUMERATOR and TURNAROUND_DENOMINATOR in table 3-3 of reference [36]) are determined by the frequency band of the transmitted carrier to which the received carrier is coherently related. For CCSDS 401.0-conformant carriers, the turnaround ratios are specified in reference [23]. For CCSDS 415.1-conformant carriers, the turnaround ratio is specified in reference [25]. The TDM Segment Generation FR obtains this information through the relationship identified by the Range and Doppler interface with an FR of the receiving carrier's FR Set.

Figure 9-12: Contents of the Three-Way Range Atomic Segment

9.2.2.2.8 Receive Frequency Atomic Segments

The receive frequency (see RECEIVE_FREQ, 3.5.2.8 of reference [36]) is reported by a return space link FR within the Physical Channel FR Stratum. The information necessary to configure a Receive Frequency path is as follows:

- a) The name of the ESLT aperture that is used by the receiving FR instance. This name appears in the PARTICIPANT_1 metadata keyword of the Metadata Sections of the TDM Atomic Segments generated for a Receive Frequency path. The name shall be the name assigned to the ESLT aperture in the SANA Service Sites and Apertures registry (reference [33]).
- b) The name of the Space User Node that transmits the signal being measured. This name appears in the PARTICIPANT_2 metadata keyword of the Metadata Sections of the TDM Atomic Segments generated for a Receive Frequency path. If the Space User Node has a single transponder or transmitter that can be used in the generation of radiometric measurements, then the Space User Node name shall be the abbreviated name specified in the SANA Spacecraft registry (reference [35]). If the Space User Node has multiple transponders or transmitters, the Space User Node name is that of the transponder/transmitter that is the source of the carrier signal. The name of the transponder/transmitter shall be formed by the concatenation of the SANA Spacecraft registry abbreviated name and the frequency band in which the transponder/transmitter operates: <Space User Node Name>-<frequency band>, where <frequency band> is the SANA Frequency Band Designator specified in table 2-1 of reference [26]. (See the NOTE under 9.2.2.2.2 b).)
- c) The reporting period at which the Receive Frequency Atomic Segments are to be generated, in seconds.

NOTE – An ESLT implementation may have this value fixed by the implementation. In such a case, the value of this parameter is constrained to be the value that is supported by the implementation. Also, an ESLT implementation may generate Receive Frequency measurements on a non-periodic basis. In such a case, the reporting period configuration parameter of the TDM Segment Generation instance is set to zero.

- d) The frequency band of the received carrier signal, using the SANA Frequency Band Designator specified in table 2-1 of reference [26].
- e) The FR Name of the Physical Channel FR that receives the carrier (and therefore has the Receive Frequency provided interface for that Receive Frequency data).

Figure 9-13 specifies the contents of the Receive Frequency Atomic Segment generated by the TDM Segment Generation function.

META_START	
TIME_SYSTEM	= UTC
START_TIME	= <time that the carrier frequency is sampled>
STOP_TIME	= <time that the carrier frequency is sampled>
PARTICIPANT_1	= <name of the ESLT aperture>
PARTICIPANT_2	= <name of the Space User Node[-<frequency band>]>
MODE	= SEQUENTIAL
PATH	= 2,1
RECEIVE_BAND	= <receive frequency band>
META_STOP	
DATA_START	
RECEIVE_FREQ	= <receive frequency in Hz>
DATA_STOP	

Figure 9-13: Contents of the Receive Frequency Atomic Segment

9.2.2.2.9 Transmit Frequency Atomic Segments

The transmit frequency (see TRANSMIT_FREQ, 3.5.2.9 of reference [36]) is reported by a forward space link FR within the Physical Channel FR Stratum. The information necessary to configure a Transmit Frequency path is as follows:

- a) The name of the ESLT aperture that is used by the transmitting FR instance. This name appears in the PARTICIPANT_1 metadata keyword of the Metadata Sections of the TDM Atomic Segments generated for a Transmit Frequency path. The name shall be the name assigned to the ESLT aperture in the SANA Service Sites and Apertures registry (reference [33]).
- b) The name of the Space User Node that receives the signal being measured. This name appears in the PARTICIPANT_2 metadata keyword of the Metadata Sections of the TDM Atomic Segments generated for a Transmit Frequency path. If the Space User Node has a single transponder or transmitter that can be used in the generation of radiometric measurements, then the Space User Node name shall be the abbreviated name specified in the SANA Spacecraft registry (reference [35]). If the Space User Node has multiple transponders or transmitters, the Space User Node name is that of the transponder/transmitter that is the source of the carrier signal. The name of the transponder/transmitter shall be formed by the concatenation of the SANA Spacecraft registry abbreviated name and the frequency band in which the transponder/transmitter operates: <Space User Node Name>-<frequency band>, where <frequency band> is the SANA Frequency Band Designator specified in table 2-1 of reference [26]. (See the NOTE under 9.2.2.2.2 b.)

- c) The reporting period at which the Transmit Frequency Atomic Segments are to be generated, in seconds.

NOTE – An ESLT implementation may have this value fixed by the implementation. In such a case, the value of this parameter is constrained to be the value that is supported by the implementation. Also, an ESLT implementation may generate transmit frequency measurements on a non-periodic basis. In such a case, the reporting period configuration parameter of the TDM Segment Generation instance is set to zero.

- d) The frequency band of the transmitted carrier signal, using the SANA Frequency Band Designator specified in table 2-1 of reference [26].
- e) The FR Name of the Physical Channel FR that transmits the carrier (and therefore has the transmit frequency provided interface for that transmit frequency data).

Figure 9-14 specifies the contents of the Transmit Frequency Atomic Segment generated by the TDM Segment Generation function.

META_START	
TIME_SYSTEM	= UTC
START_TIME	= <time that the carrier frequency is sampled>
STOP_TIME	= <time that the carrier frequency is sampled>
PARTICIPANT_1	= <name of the ESLT aperture>
PARTICIPANT_2	= <name of the Space User Node[-<frequency band>]>
MODE	= SEQUENTIAL
PATH	= 1,2
TRANSMIT_BAND	= <transmit frequency band>
META_STOP	
DATA_START	
TRANSMIT_FREQ_1	= <transmit frequency in Hz>
DATA_STOP	

Figure 9-14: Contents of the Transmit Frequency Atomic Segment

9.2.2.2.10 Transmit Frequency Rate Atomic Segments

The transmit frequency rate (see TRANSMIT_FREQ_RATE, 3.5.2.10 of reference [36]) is reported by a forward space link FR within the Physical Channel FR Stratum. The information necessary to configure a Receive Frequency Rate path is as follows:

- a) The name of the ESLT aperture that is used by the transmitting FR instance. This name appears in the PARTICIPANT_1 metadata keyword of the Metadata Sections of the TDM Atomic Segments generated for a Transmit Frequency Rate path. The name shall be the name assigned to the ESLT aperture in the SANA Service Sites and Apertures registry (reference [33]).

- b) The name of the Space User Node that receives the signal being measured. This name appears in the PARTICIPANT_2 metadata keyword of the Metadata Sections of the TDM Atomic Segments generated for a Transmit Frequency Rate path. If the Space User Node has a single transponder or transmitter that can be used in the generation of radiometric measurements, then the Space User Node name shall be the abbreviated name specified in the SANA Spacecraft registry (reference [35]). If the Space User Node has multiple transponders or transmitters, the Space User Node name is that of the transponder/transmitter that is the source of the carrier signal. The name of the transponder/transmitter shall be formed by the concatenation of the SANA Spacecraft registry abbreviated name and the frequency band in which the transponder/transmitter operates: <Space User Node Name>-<frequency band>, where <frequency band> is the SANA Frequency Band Designator specified in table 2-1 of reference [26]. (See the NOTE under 9.2.2.2.2 b.)
- c) The reporting period at which the Transmit Frequency Rate Atomic Segments are to be generated, in seconds.

NOTE – An ESLT implementation may have this value fixed by the implementation. In such a case, the value of this parameter is constrained to be the value that is supported by the implementation. Also, an ESLT implementation may generate transmit frequency rate measurements on a non-periodic basis. In such a case, the reporting period configuration parameter of the TDM Segment Generation instance is set to zero.

- d) The frequency band of the transmitted carrier signal, using the SANA Frequency Band Designator specified in table 2-1 of reference [26].
- e) The FR Name of the Physical Channel FR that transmits the carrier (and therefore has the Transmit Frequency provided interface for that transmit frequency rate data).

Figure 9-15 specifies the contents of the Transmit Frequency Rate Atomic Segment generated by the TDM Segment Generation function.

META_START	
TIME_SYSTEM	= UTC
START_TIME	= <time that the carrier frequency is sampled>
STOP_TIME	= <time that the carrier frequency is sampled>
PARTICIPANT_1	= <name of the ESLT aperture>
PARTICIPANT_2	= <name of the Space User Node[-<frequency band>]>
MODE	= SEQUENTIAL
PATH	= 1,2
TRANSMIT_BAND	= <transmit frequency band>
META_STOP	
DATA_START	
TRANSMIT_FREQ_RATE_1	= <transmit frequency in Hz/s>
DATA_STOP	

Figure 9-15: Contents of the Transmit Frequency Rate Atomic Segment

9.2.2.2.11 Antenna Angles Atomic Segments

The antenna angle data (see 3.5.4.2 and 3.5.4.3 of reference [36]) is reported by a return space link FR within the Aperture FR Stratum. The information necessary to configure an Antenna Angles path is as follows:

- a) The name of the antenna (aperture). This name appears in the PARTICIPANT_1 metadata keyword of the Metadata Sections of the TDM Atomic Segments generated for an Antenna Angles path. The name shall be the name assigned to the antenna in the SANA Service Sites and Apertures registry (reference [33]).
- b) The name of the Space User Node to which the antenna points. This name appears in the PARTICIPANTS_2 metadata keyword of the Metadata Sections of the TDM Atomic Segments generated for an Antenna Angles path. The Space User Node name shall be the abbreviated name specified in the SANA Spacecraft registry (reference [35]).
- c) The reporting period at which the Antenna Angles Atomic Segments are to be generated, in seconds.

NOTE – An ESLT implementation may have this value fixed by the implementation. In such a case, the value of this parameter is constrained to be the value that is supported by the implementation. Also, an ESLT implementation may generate Antenna Angles measurements on a non-periodic basis. In such a case, the reporting period configuration parameter of the TDM Segment Generation instance is set to zero.

- d) The FR Name of the Aperture FR that represents the aperture (and therefore has the Aperture Data provided interface for that Antenna Angles data).

Figure 9-16 specifies the contents of the Antenna Angles Atomic Segment generated by the TDM Segment Generation function.

META_START	
TIME_SYSTEM	= UTC
START_TIME	= <time that the antenna angles are sampled>
STOP_TIME	= <time that the antenna angles are sampled>
PARTICIPANT_1	= <name of the antenna>
PARTICIPANT_2	= <name of the Space User Node[-<frequency band>]>
MODE	= SEQUENTIAL
PATH	= 1,2
ANGLE_TYPE	= 'AZEL', 'RADEC', 'XEYN', or 'XSYE'*
META_STOP	
DATA_START	
ANGLE_1	= <angle, right ascension, or 'X' angle measurement, depending on ANGLE_TYPE>
ANGLE_2	= <elevation, declination, or 'Y' angle measurement, depending on ANGLE_TYPE>
DATA_STOP	
* The angle type is a characteristic of the aperture. The TDM Segment Generation FR obtains this information through the relationship established by the Aperture Data interface with the Aperture-Stratum FR. The valid values for ANGLE_TYPE are specified in table 3-3 of reference [36].	

Figure 9-16: Contents of the Antenna Angles Atomic Segment

9.2.2.3 Configuration Parameter Structure in the SANA Functional Resources Registry

The configuration parameters of the TDM Segment Generation FR are specified in the SANA Functional Resources registry (reference [22]) and registered under the parameters subtree (`{TdmSegmentGen 1}`), where for the configuration parameters, the `configured` attribute = 'true'.

The TDM Segment Generation FR configuration information is organized as a set of tables, in which each table contains the configuration information for all of the tracking data paths for one of the 10 tracking data types reported by the TD service (carrier power, carrier-power-to-noise spectral density ratio, ranging-power-to-noise spectral density ratio, Doppler (instantaneous), Doppler (integrated), range, receive frequency, transmit frequency, transmit frequency rate, or antenna angle pairs). The presence of a table for each tracking data type permits a Service Package to include multiple tracking data paths (e.g., ranging on both S-band and X-band for a Mission spacecraft that can communicate on both links simultaneously). For a given Service Package, the TDM Segment Generation function configuration information may have various combinations of tracking-data-path tables with no entries, tables with only one path per table, and tables with multiple paths per table.

Each table is represented by a complex-valued configuration parameter consisting of zero or more lists of records, where each record contains the configuration parameters for one path for the tracking data type of that table. Because each such configuration parameter represents a whole table, the lowest level of granularity at which configuration information is initially set, retrieved, and (possibly) subsequently modified is at the whole-table level.

In each table, each record has a `trackingDataPathId` parameter that is unique across all records in all tables for an instance of the TDM Segment Generation FR. The primary purpose of the `trackingDataPathId` is to serve as an index by which a Tracking Data CSTS instance (see 11.7) can be configured to receive the tracking data paths that are of interest to the user of that TD service instance.

NOTE – In SM configuration profiles, the uniqueness of the `trackingDataPathId` parameters is enforced by casting these parameters as XML Schema type `xsd:ID`.

9.2.2.4 SAPs and Ancillary Interfaces Used by This Functional Resource

9.2.2.4.1 SAPs Accessed by This Functional Resource

The TDM Segment Generation FR does not perform in the Accessor role because there is no single FR instance of another type that can contain it.

9.2.2.4.2 SAPs Hosted by This Functional Resource

The TDM Segment Generation FR has a TDM Segments SAP that can be accessed by multiple TD-CSTS Provider FR instances and/or one instance of the TDM Recording Buffer FR.

9.2.2.4.3 Ancillary Interfaces Required by This Functional Resource

The TDM Segment Generation FR requires zero or more Aperture Data interfaces. Each Aperture Data interface links to a source of aperture data. The only aperture data relevant to the TDM Segment Generation FR is pointing angle data (as available).

The TDM Segment Generation FR requires zero or more Range and Doppler interfaces. Each Range and Doppler interface links to a source of range, Doppler, and ranging-power-to-spectral-density data (as available).

The TDM Segment Generation FR requires zero or more Receive Frequency interfaces. Each Receive Frequency interface links to a source of receive frequency, carrier power, and carrier-power-to-noise-spectral-density data (as available).

The TDM Segment Generation FR requires zero or more Transmit Frequency interfaces. Each Transmit Frequency interface links to a source of transmit frequency and transmit frequency rate data (as available).

9.2.2.4.4 Ancillary Interfaces Provided by This Functional Resource

None.

9.3 NON-VALIDATED RADIOMETRIC DATA FUNCTIONAL RESOURCE SET OF THE SLS RADIOMETRIC DATA PRODUCTION FUNCTIONAL RESOURCE STRATUM

9.3.1 OVERVIEW

The Non-Validated Radiometric Data Collection FR Set of the SLS Radiometric Data Production FR Stratum consists of the Non-Validated Radiometric Data Collection FR. Figure 9-17 illustrates the member of the Non-Validated Radiometric Data Collection FR Set.

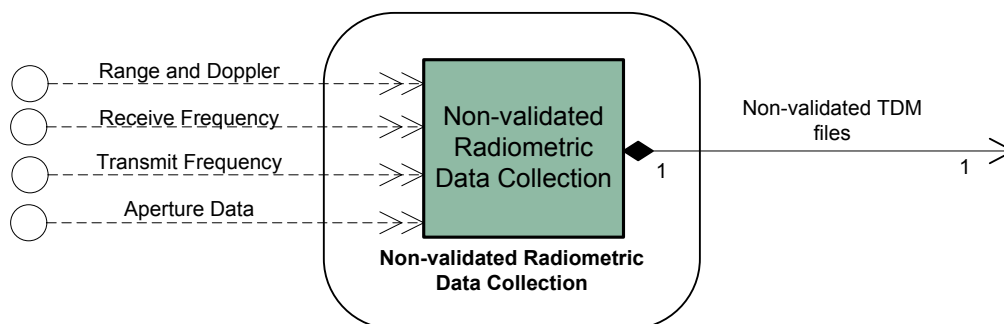

Figure 9-17: Member Functional Resource of the Non-Validated Radiometric Data Collection Functional Resource Stratum

9.3.2 NON-VALIDATED RADIOMETRIC DATA COLLECTION

9.3.2.1 General

The FR classifier of the Non-Validated Radiometric Data Collection FR Type is `NonValRmDataCollection`.

The purpose of the Non-Validated Radiometric Data Collection function is to collect raw tracking, STEC, tropospheric, and meteorological data from the various resources that produce those data and create TDM files, as defined in reference [36]. These non-validated TDM files are stored in a Non-Validated Radiometric Data Store (see 10.4.2). The primary purpose of the non-validated radiometric data is to be input to a radiometric validation process that results in validated radiometric data TDMs that are stored in a Validated Radiometric Data Store (see 10.5.2).

NOTES

- 1 The radiometric validation process involves analyst interaction and is therefore not performed during the space link session. The performance of radiometric data validation is a human-directed activity and is not performed by an FR.
- 2 The non-validated TDM files may also be available for transfer directly from the Non-Validated Radiometric Data Store, but the mechanisms for doing so are mission- and/or provider-specific and without a recommended practice.

There is one instance of the Non-Validated Radiometric Data Collection FR for each RF antenna with which the production of Non-Validated Radiometric Data is associated. For example, if an ESLT is collecting raw radiometric data through two antennas, there will be two instances of the Non-Validated Radiometric Data Collection FR.

NOTE – The Non-Validated Radiometric Data Collection FR collects data from RF antennas only. That is, this FR does not collect optical or radar observables.

There are no CCSDS Recommended Standards that specify the Non-Validated Radiometric Data Collection function, and in particular there are no Recommended Standards that define the managed parameters that must be configured to relate the contents of the resulting TDMs to the FRs that produce the data reported in the TDMs. The following description serves as the definition of the function performed by the Non-Validated Radiometric Data Collection FR.

9.3.2.2 Non-Validated Radiometric Data Collection Function

The Non-Validated Radiometric Data Collection function can generate TDM files that contain data for non-observable groups:

- sequential range;
- Doppler instantaneous;
- Sequential receive transmit Doppler;
- Doppler integrated;
- Doppler count;
- antenna angle pairs;
- STEC;
- tropospheric data; and
- Meteorological data.

This FR collects the raw, that is, non-validated, radiometric observables and generates TDM files where each file contains only the observable group per file as identified by the element `observableGroupType` of the `nonValRmFiles` parameter (see the `NonValRmDataCollection` FR in the SANA Functional Resources registry, reference [22]). Some observable group elements may be optional. The actual keywords and associated values contained in the TDM file data segments are identified by the `DATA_TYPES` keyword value in the Metadata Section.

The TDM Header keyword values shall be set as agreed between provider and user. Therefore the setting of these keywords is not covered by parameters of this FR.

Some of the TDM Metadata Section keyword values will be the same for all files generated by this FR. The value assigned to the keyword `TIME_SYSTEM` is always 'UTC'. If the keyword `MODE` is applicable, the assigned value is always 'SEQUENTIAL'. The value assigned to the `DATA_QUALITY` keyword is always 'RAW' and the value assigned to the `CORRECTION_APPLIED` keyword is always 'NO'.

The observable groups for which TDM files are to be generated are specified by the parameter `nonValRmFiles`, which also specifies the sampling rate and the observation time that is to be covered by each file containing the given observable group.

The collection of data is limited to data available at a single ESLT. Some observables specified in CCSDS 503.0-B-2 require data from more than one ESLT. As a consequence, different paths need to be specified for differenced range, differenced Doppler, and Very Long Baseline Interferometry data, unless none of the participants is a spacecraft, in which case no path is specified (clock bias and clock drift). Such data are not collected by this FR.

By convention, the `PARTICIPANT_1` is an RF antenna. Therefore this FR does not collect optical or radar observables as covered by the `MAG` and `RCS` keywords.

Although not explicitly specified by the parameters of this FR, the keywords `META_START` and `META_STOP` shall delimit each Metadata Section. Likewise, each Data Section shall be delimited by the keywords `DATA_START` and `DATA_STOP`. Furthermore, each Metadata Section shall contain the `START_TIME` and the `STOP_TIME` keywords and their values.

Once the generation of a TDM file by this FR is completed, it is passed to the `NonValRmDataStore` FR.

9.3.2.3 SAPs and Ancillary Interfaces Used by This Functional Resource

9.3.2.3.1 SAPs Accessed by This Functional Resource

The Non-Validated Radiometric Data Collection FR does not perform in the Accessor role because there is no single FR instance of another type that can contain it.

9.3.2.3.2 SAPs Hosted by This Functional Resource

The Non-Validated Radiometric Data Collection has a Non-Validated TDM Files SAP that is accessed by one Non-Validated Radiometric Data Store FR.

9.3.2.3.3 Ancillary Interfaces Required by This Functional Resource

The Non-Validated Radiometric Data Collection FR requires zero or more Aperture Data interfaces. Each Aperture Data interface links to a source of aperture pointing angle, STEC, Tropospheric, and/or Meteorological data (as available and appropriate).

Non-Validated Radiometric Data Collection FR requires zero or more Range and Doppler interfaces. Each Range and Doppler interface links to a source of range, Doppler, and ranging-power-to-spectral-density data (as available).

The Non-Validated Radiometric Data Collection FR requires zero or more Receive Frequency interfaces. Each Receive Frequency interface links to a source of receive frequency, carrier power, and carrier-power-to-noise-spectral-density data (as available).

The Non-Validated Radiometric Data Collection FR requires zero or more Transmit Frequency interfaces. Each Transmit Frequency interface links to a source of transmit frequency and transmit frequency rate data (as available).

9.3.2.3.4 Ancillary Interfaces Provided by This Functional Resource

None.

10 OFFLINE DATA STORAGE FUNCTIONAL RESOURCE STRATUM

10.1 GENERAL

The Offline Data Storage FR Stratum is the stratum for FR Types representing data storage functions that (a) store telemetry received during a Space Link Session for subsequent retrieval via offline or complete data delivery transfer services and (b) store forward-link data for subsequent transmission during a Space Link Session.

The Offline Data Storage FR Stratum has five FR Sets:

- Offline Frame Buffer;
- TDM Recording Buffer;
- Non-Validated Radiometric Data Store;
- Delta-DOR Raw Data Store; and
- Validated Radiometric Data Store.

The Offline Data Storage FRs are persistent in that they exist outside the lifetimes of the space link services that are executed as part of Space Link Sessions. The individual operational configuration profiles, which are instantiated only for the duration of the time that they are ‘scheduled’, may include offline data storage FR instances, but they cannot control the configuration of such FR instances.

As a practical matter, in most cases the physical resources that realize Offline Data Storage FR instances will reside at individual ESLTs. Each Offline Data Storage FR instance must be mappable to real storage resources in each ESLT that may instantiate that Offline Data Storage FR.

10.2 OFFLINE FRAME BUFFER FUNCTIONAL RESOURCE SET OF THE OFFLINE DATA DELIVERY PRODUCTION FUNCTIONAL RESOURCE STRATUM

10.2.1 OVERVIEW

The Offline Frame Buffer FR Set of the Offline Data Storage FR Stratum consists of the Offline Frame Buffer FR. Figure 10-1 illustrates the member FR of the Offline Frame Buffer FR Set.

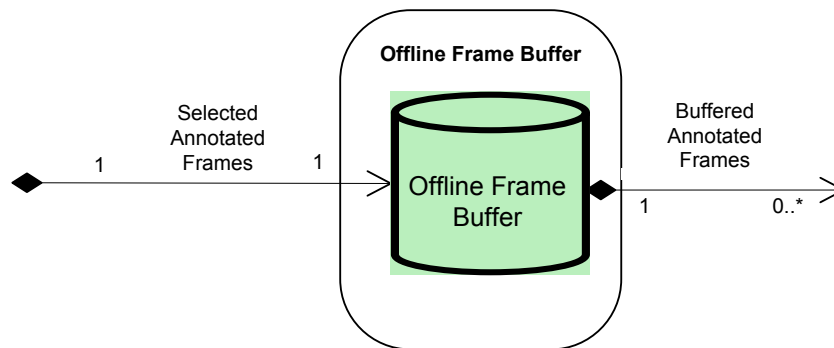

Figure 10-1: Member Functional Resource of the Offline Frame Buffer Functional Resource Set

10.2.2 OFFLINE FRAME BUFFER

10.2.2.1 General

The FR classifier of the Offline Frame Buffer FR Type is `OfflineFrameBuffer`.

The Offline Frame Buffer is a repository of return transfer frames that are subsequently retrieved by offline return SLE transfer service instances that carry transfer frames or space link data units that have been transferred across the space link within those transfer frames.

The Offline Frame Buffer FR corresponds to the Offline Frame Buffer production entity defined in the *SLE RAF* and *RCF Service Specification* Recommended Standards (references [2] and [3]).

NOTE – The Offline Frame Buffer for a given physical channel symbol stream may be shared by multiple offline RAF Transfer Service (TS) and/or Return Channel Frame TS service instances.

10.2.2.2 SAPs and Ancillary Interfaces Used by This Functional Resource

10.2.2.2.1 SAPs Accessed by This Functional Resource

The Offline Frame Buffer FR accesses the Selected Annotated Frames SAP.

10.2.2.2.2 SAPs Hosted by This Functional Resource

The Frame Data Sink FR has a Buffered Annotated Frames SAP that can be accessed by multiple Accessors.

10.2.2.2.3 Ancillary Interfaces Required by This Functional Resource

None.

10.2.2.2.4 Ancillary Interfaces Provided by This Functional Resource

None.

10.3 TRACKING DATA MESSAGE RECORDING BUFFER FUNCTIONAL RESOURCE SET OF THE OFFLINE DATA STORAGE FUNCTIONAL RESOURCE STRATUM

10.3.1 OVERVIEW

The TDM Recording Buffer FR Set of the Offline Data Storage FR Stratum consists of the TDM Recording Buffer FR. Figure 10-2 illustrates the member FR of the TDM Recording Buffer FR Set.

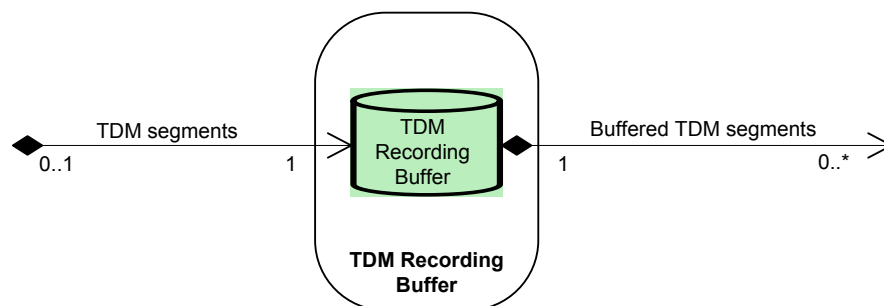

Figure 10-2: Internal Composition of the TDM Recording Functional Resource Set

10.3.2 TDM RECORDING BUFFER

10.3.2.1 General

The FR classifier of the TDM Recording Buffer FR Type is `TdmRecordingBuffer`.

The TDM Recording Buffer is a repository of tracking data segments that are subsequently retrieved by Tracking Data CSTS Provider instances operating in the complete data transfer mode (see 11.7).

The TDM Recording Buffer FR corresponds to the Recording Buffer production entity defined in annex F3 of the forthcoming *CSTS Tracking Data* Recommended Standard (reference [8]).

An instance of the TDM Recording Buffer records all TDM Atomic Segments generated by the TDM Segment Generation FR instance (see 9.2.2) with which it is associated. A TDM Recording Buffer instance makes available all TDM Atomic Segments it retains to any TD-CSTS Provider FR instance (11.7.2) with which it is associated. Each TD-CSTS Provider FR instance is configured to receive a selection of TDM Atomic Segments for one or more tracking data types. The selection is configured in terms of *tracking data paths* that are created by the TDM Segment Generation FR instance (see 9.2.2) that is the source of TDM Segments for the TDM Recording Buffer.

NOTE – The TDM Recording Buffer retains the tracking data path information associated with the TDM Atomic Segments so that the associated TD-CSTS Provider instances can be configured to retrieve and transfer the desired TDM Atomic Segments.

Each instance of the TDM Recording Buffer has an allocated maximum storage capacity, in megabytes. Each TDM Recording Buffer instance retains all recorded TDM Segments until the maximum storage capacity is reached, at which time, Segments are discarded in FIFO order.

10.3.2.2 SAPs and Ancillary Interfaces Used by This Functional Resource

10.3.2.2.1 SAPs Accessed by This Functional Resource

When configured as part of an SLS configuration, the TDM Recording Buffer accesses a TDM Segment Generation FR instance (see 9.2.2) via a TDM Segments SAP.

10.3.2.2.2 SAPs Hosted by This Functional Resource

When configured as part of a retrieval configuration, the TDM Recording Buffer FR has a Buffered TDM Segments SAP that can be accessed by multiple TD-CSTS Provider FR instances.

10.3.2.2.3 Ancillary Interfaces Required by This Functional Resource

None.

10.3.2.2.4 Ancillary Interfaces Provided by This Functional Resource

None.

10.4 NON-VALIDATED RADIOMETRIC DATA STORE FUNCTIONAL RESOURCE SET OF THE OFFLINE DATA STORAGE FUNCTIONAL RESOURCE STRATUM

10.4.1 OVERVIEW

The Non-Validated Radiometric Data Store FR Set of the Offline Data Storage FR Stratum consists of the Non-Validated Radiometric Data Store FR. Figure 10-3 illustrates the member FR of the Non-Validated Radiometric Data Store FR Set.

NOTE – The Non-Validated Radiometric Data Store has no SAP, because there is no FR Set or FR that connects to it in any automated way for the purposes of acquiring the contents of the data store. The radiometric data validation process is a manual process that culminates in the creation of a validated radiometric dataset in a validated radiometric data store (see 10.5.210.5).

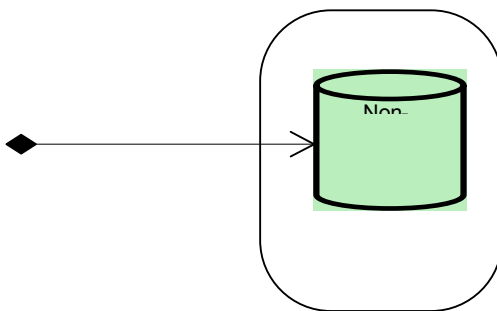

Figure 10-3: Member Functional Resource of the Non-Validated Radiometric Data Store Functional Resource Set

10.4.2 NON-VALIDATED RADIOMETRIC DATA STORE

10.4.2.1 General

The FR classifier of the Non-Validated Radiometric Data Store FR Type is `NonValRmDataStore`.

The Non-Validated Radiometric Data Store is a repository of TDM files containing non-validated (raw) radiometric, media, and meteorological data collected at a given ESLT. An instance of the Non-Validated Radiometric Data Store FR records all TDM files generated by the Non-Validated Radiometric Data Collection FR instance with which it is associated.

The primary purpose of the non-validated radiometric data TDM files is for subsequent validation locally within the ESLT. In this case, the TDM files are to be retrieved by the navigation team in charge of generating TDM files containing validated radiometric data. The generation of the validated radiometric data may require the processing of observables collected at other ESLTs and/or other facilities. How such externally generated data is received by the navigation team, and the resources used by that team to generate the

validated radiometric data, is not standardized and not represented by any schedulable FRs. Following validation of the data, the resultant validated TDM files are stored in an instance of the Validated Radiometric Data Store (10.5).

The non-validated TDM files may also be transferred from the Non-Validated Radiometric Data Store outside the ESLT for further processing. For the current version of the FRM, the method by which non-validated TDM files may be retrieved is not standardized and not represented by any FRs.

10.4.2.2 SAPs and Ancillary Interfaces Used by This Functional Resource

10.4.2.2.1 SAPs Accessed by This Functional Resource

When configured as part of an SLS configuration, the Non-Validated Radiometric Data Store accesses a Non-Validated Radiometric Data Collection FR instance (see 9.2.2) via a Non-Validated TDM Files SAP.

10.4.2.2.2 SAPs Hosted by This Functional Resource

None.

NOTE – A Non-Validated Radiometric Data Store FR may also be accessed locally (i.e., within the ESLT) if validation of the radiometric data is performed locally. However, the method by which such local accesses are performed is outside the scope of the FRM.

10.4.2.2.3 Ancillary Interfaces Required by This Functional Resource

None.

10.4.2.2.4 Ancillary Interfaces Provided by This Functional Resource

None.

10.5 VALIDATED RADIOMETRIC DATA STORE FUNCTIONAL RESOURCE SET OF THE OFFLINE DATA STORAGE FUNCTIONAL RESOURCE STRATUM

10.5.1 OVERVIEW

The Validated Radiometric Data Store FR Set of the Offline Data Storage FR Stratum consists of the Validated Radiometric Data Store FR. Figure 10-4 illustrates the member FR of the Validated Radiometric Data Store FR Set.

NOTE – The Validated Radiometric Data Store is not an Accessor of any other FR because there is no FR Set or FR that connects to it in any automated way to be the source of the data. The radiometric data validation process is a manual process that transforms non-validated radiometric data (see 10.4) into a validated TDM file.

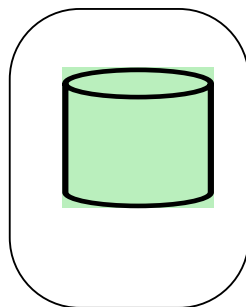

Figure 10-4: Member Functional Resource of the Validated Radiometric Data Store Functional Resource Set

10.5.2 VALIDATED RADIOMETRIC DATA STORE

10.5.2.1 General

The FR classifier of the Validated Radiometric Data Store FR Type is `ValRmDataStore`.

The Validated Radiometric Data Store is a repository of validated TDM files typically generated by the navigations teams of the space flight agencies. The validated TDM files may contain observables requiring processing of raw radiometric data collected at more than one ESLT or other facilities. The raw radiometric data may include the non-validated radiometric data collected by the Non-Validated Radiometric Data Collection FR (9.3), raw Delta-DOR data collected by the `DdorRawDataCollection` FR (5.4), or other raw radiometric data not collected by any CCSDS-standard raw radiometric data collection FR.

Storage space allocation is per mission. The applied data retention policy is FIFO.

For the current version of the FRM, the method by which non-validated TDM files may be retrieved is not standardized and not represented by any FRs.

10.5.2.2 SAPs and Ancillary Interfaces Used by This Functional Resource

10.5.2.2.1 SAPs Accessed by This Functional Resource

None. The validated TDM files in the Validated Radiometric Data Store are created by a manual process and the method by which those files are entered into the data store is outside the scope of the FRM.

10.5.2.2.2 SAPs Hosted by This Functional Resource

None.

10.5.2.2.3 Ancillary Interfaces Required by This Functional Resource

None.

10.5.2.2.4 Ancillary Interfaces Provided by This Functional Resource

None.

10.6 DELTA-DOR RAW DATA STORE FUNCTIONAL RESOURCE SET OF THE OFFLINE DATA STORAGE FUNCTIONAL RESOURCE STRATUM

10.6.1 OVERVIEW

The Delta-DOR Raw Data Store FR Set of the Offline Data Storage FR Stratum consists of the Delta-DOR Raw Data Store FR. Figure 10-5 illustrates the member FR of the Delta-DOR Raw Data Store FR Set.

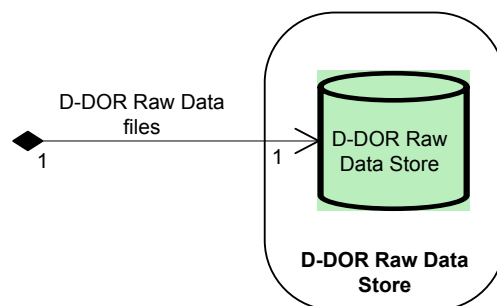

Figure 10-5: Member Functional Resource of the Delta-DOR Raw Data Store Functional Resource Set

10.6.2 DELTA-DOR RAW DATA STORE

10.6.2.1 General

The FR classifier of the Delta-DOR Raw Data Store FR Type is `DdorRawDataStore`.

The Delta-DOR Raw Data Store is the repository of files that conform to the standard Delta-DOR Raw Data file format specified in *Delta-DOR Raw Data Exchange Format* (reference [31]). The method(s) by which the Delta-DOR raw data files are transferred out of the ESLT are outside the current scope of the FRM.

10.6.2.2 SAPs and Ancillary Interfaces Used by This Functional Resource

10.6.2.2.1 SAPs Accessed by This Functional Resource

The Delta-DOR Raw Data Store accesses the Delta-DOR Raw Data File SAP of a Delta-DOR Raw Data Collection FR instance.

10.6.2.2.2 SAPs Hosted by This Functional Resource

None.

NOTE – A Delta-DOR Raw Data Store FR may also be accessed locally (i.e., within the ESLT) if Delta-DOR data correlation is performed locally. However, for such correlation to occur, Delta-DOR raw data from other ESLTs must be available. The method by which Delta-DOR raw data files are obtained from other ESLTs is outside the current scope of the FRM.

10.6.2.2.3 Ancillary Interfaces Required by This Functional Resource

None.

10.6.2.2.4 Ancillary Interfaces Provided by This Functional Resource

None.

11 DATA TRANSFER SERVICES FUNCTIONAL RESOURCES STRATUM

11.1 GENERAL

Data Transfer Services FR Stratum has six FR Sets:

- SLE Forward CLTU FR Set;
- FF-CSTS FR Set;
- SLE Return All Frames FR Set;
- SLE Return Channel Frames FR Set;
- SLE Return Operational Control Fields FR Set; and
- Tracking Data CSTS FR Set.

11.2 SLE FORWARD CLTU FUNCTIONAL RESOURCE SET OF THE DATA TRANSFER SERVICES STRATUM

11.2.1 OVERVIEW

The SLE Forward CLTU FR Set of the Data Transfer Services FR Stratum consists of the FCLTU Transfer Service Provider FR. Figure 11-1 illustrates the member FR of the SLE Forward CLTU FR Set.

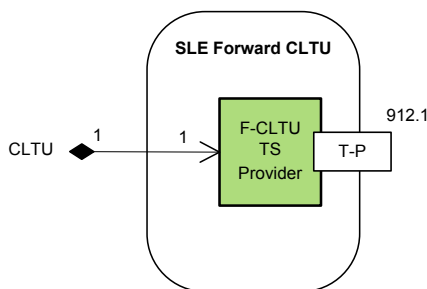

Figure 11-1: Member Functional Resource of the SLE Forward CLTU Functional Resource Set

11.2.2 FCLTU TRANSFER SERVICE PROVIDER

11.2.2.1 General

The FR classifier of the FCLTU TS Provider FR Type is `FcltuTsProvider`.

The FCLTU TS Provider FR corresponds to the functions specified in the *SLE Forward CLTU Service Specification* Recommended Standard (reference [27]).

11.2.2.2 SAPs and Ancillary Interfaces Used by This Functional Resource

11.2.2.2.1 SAPs Accessed by This Functional Resource

The FCLTU TS Provider FR accesses the CLTU SAP.

11.2.2.2.2 SAPs Hosted by This Functional Resource

None.

11.2.2.2.3 Ancillary Interfaces Required by This Functional Resource

None.

11.2.2.2.4 Ancillary Interfaces Provided by This Functional Resource

None.

11.3 FORWARD FRAME CSTS FUNCTIONAL RESOURCE SET OF THE DATA TRANSFER SERVICES SPECTRUM

11.3.1 OVERVIEW

The FF-CSTS SC FR Set of the Data Transfer Services Stratum consists of the FF-CSTS Provider FR. Figure 11-2 illustrates the FR Type that constitutes the FF-CSTS FR Set.

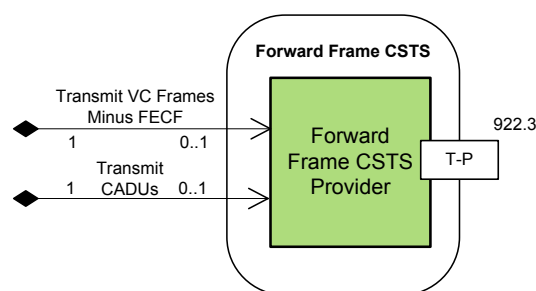

Figure 11-2: Member of the FF-CSTS Functional Resource Set

11.3.2 FF-CSTS PROVIDER

11.3.2.1 General

The FR classifier of the FF-CSTS Provider FR Type is `FwdFrameCstsProvider`.

The FF-CSTS Provider FR corresponds to the functions specified in *Cross Support Transfer Service—Forward Frame Service* (reference [32]).

11.3.2.2 SAPs and Ancillary Interfaces Used by This Functional Resource

11.3.2.2.1 SAPs Accessed by This Functional Resource

In any given operational procedure, the FF-CSTS Provider FR is configured to access one and only one of two SAPs:

- a) Transmit VC Frames Minus FECF SAP, when the FR is configured to carry transfer frames; or
- b) Transmit CADUs SAP, when the FR is configured to transfer CADUs.

NOTE – Although the FF-CSTS Provider FR is capable of transferring CADUs, the CADU configuration is not used to transfer CADUs for carrying CCSDS AOS or FLF USLP transfer frames because the requirement of those SDLPs to generate dynamically randomized Only Idle Data Frames renders the CADU mode of operation essentially useless. However, the CADU configuration could possibly be used with a proprietary or legacy SDLP.

11.3.2.2.2 SAPs Hosted by This Functional Resource

None.

11.3.2.2.3 Ancillary Interfaces Required by This Functional Resource

None.

11.3.2.2.4 Ancillary Interfaces Provided by This Functional Resource

None.

11.4 SLE RETURN ALL FRAMES FUNCTIONAL RESOURCE SET OF THE DATA TRANSFER SERVICES FUNCTIONAL RESOURCE STRATUM

11.4.1 OVERVIEW

The RAF FR Set of the Data Transfer Service FR Stratum consists of the RAF TS Provider FR. Figure 11-3 illustrates the member FR of the Return All Frames FR Set.

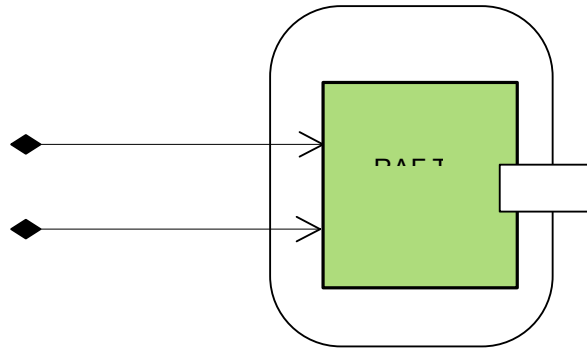

Figure 11-3: Member Functional Resource of the Return All Frames Functional Resource Set

11.4.2 RAF TS PROVIDER

11.4.2.1 General

The FR classifier of the RAF TS Provider FR Type is `RafTsProvider`.

The RAF TS Provider FR corresponds to the functions specified in the *Space Link Extension—Return All Frames Service Specification* Recommended Standard (reference [2]).

11.4.2.2 SAPs and Ancillary Interfaces Used by This Functional Resource

11.4.2.2.1 SAPs Accessed by This Functional Resource

In any given operational procedure, the RAF TS Provider FR is configured to access one and only one of two SAPs:

- a) Return All Annotated Transfer Frames SAP, when the FR is configured to operate in online mode; or
- b) Return All Buffered Transfer Frames SAP, when the FR is configured to operate in offline mode.

11.4.2.2.2 SAPs Hosted by This Functional Resource

None.

11.4.2.2.3 Ancillary Interfaces Required by This Functional Resource

None.

11.4.2.2.4 Ancillary Interfaces Provided by This Functional Resource

None.

11.5 SLE RETURN CHANNEL FRAMES FUNCTIONAL RESOURCE SET OF THE DATA TRANSFER SERVICES FUNCTIONAL RESOURCE STRATUM

11.5.1 OVERVIEW

The RCF FR Set of the Data Transfer Service FR Stratum consists of the RCF TS Provider FR. Figure 11-4 illustrates the member FR of the Return Channel Frames FR Set.

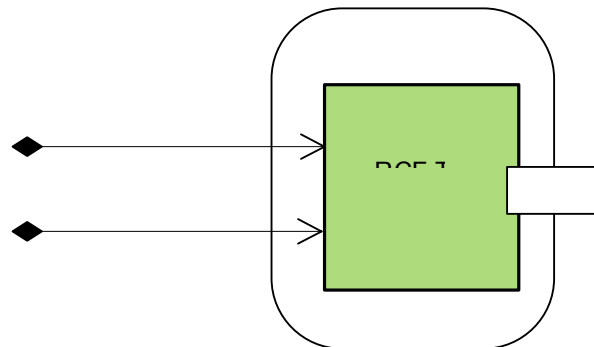

Figure 11-4: Member Functional Resource of the Return Channel Frames Functional Resource Set

11.5.2 RCF TS PROVIDER

11.5.2.1 General

The FR classifier of the RCF TS Provider FR Type is `RcfTsProvider`.

The RCF TS Provider FR corresponds to the functions specified in the *Space Link Extension—Return Channel Frames Service Specification* Recommended Standard (reference [3]).

11.5.2.2 SAPs and Ancillary Interfaces Used by This Functional Resource

11.5.2.2.1 SAPs Accessed by This Functional Resource

In any given operational procedure, the RCF TS Provider FR is configured to access one and only one of two SAPs:

- a) Return All Annotated Transfer Frames SAP, when the FR is configured to operate in online mode; or
- b) Return All Buffered Transfer Frames SAP, when the FR is configured to operate in offline mode.

11.5.2.2.2 SAPs Hosted by This Functional Resource

None.

11.5.2.2.3 Ancillary Interfaces Required by This Functional Resource

None.

11.5.2.2.4 Ancillary Interfaces Provided by This Functional Resource

None.

11.6 SLE RETURN OPERATIONAL CONTROL FIELDS FUNCTIONAL RESOURCE SET OF THE DATA TRANSFER SERVICES FUNCTIONAL RESOURCE STRATUM

11.6.1 OVERVIEW

The ROCF FR Set of the Data Transfer Services FR Stratum consists of the ROCF Transfer Service Provider FR. Figure 11-5 illustrates the member FR of the Return Operational Control Fields.

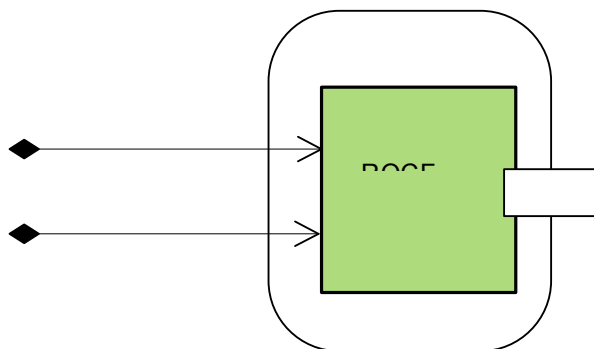

Figure 11-5: Member Functional Resource of the Return Operational Control Fields Functional Resource Set

11.6.2 ROCF TRANSFER SERVICE PROVIDER

11.6.2.1 General

The FR classifier of the ROCF TS Provider FR Type is `RocfTsProvider`.

The ROCF TS Provider FR corresponds to the functions specified in the *SLE Return Operational Control Fields Service Specification Recommended Standard* (reference [28]), with one exception. Reference [28] models the production process that supports the offline delivery mode of the ROCF service as comprising an *OCF Buffer* that contains OCFs that have been extracted and stored from transfer frames. In contrast, the ROCF TS Provider FR assumes that the data retrieved by the service instance are transfer frames from the Offline Frame Buffer (10.2.2). This approach is consistent with the known current implementations of the offline mode of the ROCF service, and has advantages over an OCF-only buffering scheme in that it allows the ROCF service to share the same frame buffer as that being used by RAF (11.4.2) and RCF (11.5.2) service instances.

11.6.2.2 SAPs and Ancillary Interfaces Used by This Functional Resource

11.6.2.2.1 SAPs Accessed by This Functional Resource

In any given operational procedure, the RCF TS Provider FR is configured to access one and only one of two SAPs:

- c) Return All Annotated Transfer Frames SAP, when the FR is configured to operate in online mode; or
- d) Return All Buffered Transfer Frames SAP, when the FR is configured to operate in offline mode.

11.6.2.2.2 SAPs Hosted by This Functional Resource

None.

11.6.2.2.3 Ancillary Interfaces Required by This Functional Resource

None.

11.6.2.2.4 Ancillary Interfaces Provided by This Functional Resource

None.

11.7 TRACKING DATA CSTS FUNCTIONAL RESOURCE SET OF THE DATA TRANSFER SERVICES FUNCTIONAL RESOURCE STRATUM

11.7.1 OVERVIEW

The Tracking Data CSTS FR Set of the Data Transfer Services FR Stratum consists of the Tracking Data CSTS Provider FR. Figure 11-6 illustrates the member FR of the Tracking Data CSTS FR Set.

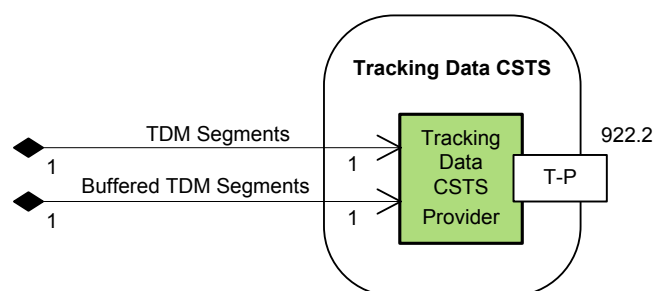

Figure 11-6: Member Functional Resource of the Tracking Data CSTS Functional Resource Set

11.7.2 TRACKING DATA CSTS PROVIDER

11.7.2.1 General

The FR classifier of the Tracking Data CSTS Provider FR Type is `TdCstsProvider`.

The Tracking Data CSTS Provider FR corresponds to the functions specified in the *CSTS Tracking Data* Recommended Standard (reference [8]).

NOTE – The TD-CSTS provides the IOAG Real-Time Data Radiometric service. In addition to delivering radiometric data in ‘real time’ (that is, during the execution of the SLS), the TD-CSTS may also be used to deliver tracking data after the conclusion of the SLS. However, the tracking data measurements will have been sampled at a defined rate.

11.7.2.2 SAPs and Ancillary Interfaces Used by This Functional Resource

11.7.2.2.1 SAPs Accessed by This Functional Resource

When configured to operate in real-time data delivery mode (see reference [8]), the Tracking Data CSTS Provider accesses the TDM Segments SAP of a TDM Segment Generation FR instance (see 9.2.2).

When configured to operate in complete data delivery mode (see reference [8]), the Tracking Data CSTS Provider accesses the Buffered TDM Segments SAP of a TDM Recording Buffer FR instance (see 10.3).

11.7.2.2.2 SAPs Hosted by This Functional Resource

None.

11.7.2.2.3 Ancillary Interfaces Required by This Functional Resource

None.

11.7.2.2.4 Ancillary Interfaces Provided by This Functional Resource

None.

12 SERVICE MANAGEMENT FUNCTIONS FUNCTIONAL RESOURCE STRATUM

12.1 GENERAL

The SM Functions FR Stratum has one FR Set:

- Monitored Data.

12.2 MONITORED DATA FUNCTIONAL RESOURCE SET OF THE SERVICE MANAGEMENT FUNCTIONS FUNCTIONAL RESOURCE STRATUM

12.2.1 OVERVIEW

The FR that comprises the Monitored Data FR Set of the SM Functions FR Stratum is the Monitored Data CSTS Provider FR.

Figure 12-1 illustrates the member FR of the Monitored Data FR Set.

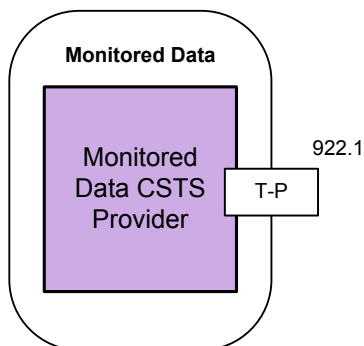

Figure 12-1: Member Functional Resource of the Monitored Data Functional Resource Set

12.2.2 MONITORED DATA CSTS PROVIDER

12.2.2.1 General

The FR classifier of the Monitored Data CSTS Provider FR Type is `MdCstsProvider`.

The Monitored Data CSTS Provider FR corresponds to the functions specified in the *CSTS—Monitored Data Service* Recommended Standard (reference [10]).

12.2.2.2 Relationships with External Functional Resource Sets

The Monitored Data CSTS Provider FR has read access to all available parameter values and notification events of all FR instances that execute in the same Service Package as that which contains the instance(s) of the Monitored Data CSTS Provider FR ('available' here refers to the subset of parameters and events that are published in the Service Agreement under which the Service Package is defined). As such, the Monitored Data CSTS Provider FR does not access any specific SAP.

NOTE – There is some consideration being given to establishing an FR Type to represent the Service Package itself. If such an FR is created, it could have a Monitored Data SAP that is accessed by one or more instances of the Monitored Data CSTS Provider FR.

13 SPACE INTERNETWORKING FUNCTIONAL RESOURCE STRATUM

There are currently no CCSDS-standard FR Sets (or FR Types) defined for the Space Internetworking FR Stratum.

ANNEX A**OBJECT IDENTIFIER OFFSETS FOR THE FUNCTIONAL
RESOURCE STRATA AND FUNCTIONAL RESOURCE SETS****(NORMATIVE)**

The OIDs of the FRs are organized according to a scheme in which the OIDs are assigned based on the FR Strata of the FRs. In this scheme, the strata are assigned 'OID offsets' beginning with 10000 for the Aperture Stratum and incrementing by 10000 for every stratum. Within a given stratum, each FR Set is given an OID offset beginning with 100 and incrementing by 100 for each FR Set within the stratum. The OID offset for a given FR Set is allocated to the root FR of that FR Set, and if there is more than one FR in the FR Set, each subsequent FR in the FR Set is allocated the next OID value, incrementing by 1. The FRM Editor allows the offset to be entered for the FR Set, and the Editor automatically assigns the OIDs to the member FRs.

This allocation scheme allows for up to 99 FR Sets within each stratum and 100 FRs within each FR Set.

In addition to the FR Sets and FRs defined in this Recommended Practice, a number of FR Sets have been tentatively identified for future development and have been assigned OID offsets. There is no commitment to define these future FR Sets, and CCSDS may reassign their OID offsets. Their presence here merely serves as an informative placeholder.

The OID offset allocation is as follows:

10000 – Aperture FR Stratum

- 10100 – RF Aperture
- 10200 – Antenna Array (future)
- 10300 – [next Aperture FR Set]

20000 – Physical Channel FR Stratum

- 20100 – CCSDS 401 Physical Channel Transmission
- 20200 – CCSDS 415 Physical Channel Transmission (future)
- 20300 – CCSDS 401 Physical Channel Reception
- 20400 – CCSDS 415 Physical Channel Reception (future)
- 20500 – Delta-DOR Raw Data Collection
- 20600 – Open Loop Data Collection
- 20700 – [next Physical Channel FR Set]

30000 – Sync and Channel Coding FR Stratum

- 30100 – TC Sync and Channel Coding
- 30200 – TM Sync and Channel Encoding
- 30300 – TM Sync and Channel Decoding
- 30400 – NOT USED
- 30500 – [next Sync and Channel Coding FR Set]

40000 – Space Link Protocol FR Stratum

- 40100 – TC Space Link Protocol Transmission
- 40200 – AOS Space Link Protocol Transmission
- 40300 – VLF Unified Space Link Protocol Transmission
- 40400 – FLF Unified Space Link Protocol Transmission
- 40500 – TM/AOS Space Link Protocol Reception
- 40600 – VLF Unified Space Link Protocol Reception (future)
- 40700 – FLF Unified Space Link Protocol Reception
- 40800 – [next Space Link Protocol FR Set]

50000 – SLS Data Delivery Production FR Stratum

- 50100 – Frame Data Sink
- 50200 – [next SLS Data Delivery Production FR Set]

60000 – SLS Radiometric Data Production FR Stratum

- 60100 – TDM Segment Generation
- 60200 – Non-Validated Radiometric Data Collection
- 60300 – [next SLS Radiometric Data Production FR Set]

70000 – Offline Data Storage FR Stratum

- 70100 – Offline Frame Buffer
- 70200 – TDM Recording Buffer
- 70300 – Non-Validated Radiometric Data Store
- 70400 – Validated Radiometric Data Store
- 70500 – Delta-DOR Raw Data Store
- 70600 – [next Offline Data Storage FR Set]

80000 – Data Transfer Services FR Stratum

- 80100 – NOT USED
- 80200 – SLE Forward CLTU
- 80300 – FF-CSTS
- 80400 – SLE RAF
- 80500 – SLE RCF
- 80600 – SLE ROCF
- 80700 – TD-CSTS
- 80800 – [next Data Transfer Services FR Set]

90000 – Service Management Functions FR Stratum

- 90100 – MD-CSTS
- 90200 – [next Service Management Functions FR Set]

100000 – Space Internetworking FR Stratum

- 100100 – Delay-Tolerant Networking (DTN) (future)
- 100200 – [next Space Internetworking FR Set]

ANNEX B

ABBREVIATIONS FOR CONSTRUCTION OF FUNCTIONAL RESOURCE AND PARAMETER/EVENT/DIRECTIVE CLASSIFIERS

(NORMATIVE)

Table B-1 lists words that are commonly used in the names of FRs and their associated PEDs. When any of these words are used in the construction of corresponding classifiers, the abbreviation for each word should be used instead.

Table B-1: Words Commonly Used in the Names of Functional Resources and Their Associated PEDs

Word	Abbreviation
Acknowledgement	Ack
Acquisition	Acqu
Advanced Orbiting Systems	Aos
All frames	Af
Antenna	Ant
AOS	Aos
Application Identifier	Apid
Attached Synchronization Marker	Asm
Bandwidth	Bwdth
CADU	Cadu
CCSDS File Delivery Protocol	Cfdp
CFDP	Cfdp
Channel	Chnl
Channel Access Data Unit	Cadu
Channel Frame	Cf
CLCW	Clew
CLTU	Cltu
Communications Link Control Word	Clew
Communications Link Transmission Unit	Cltu
Communications Operation Procedure	Cop
Control	Contr
Controlled	Contr
Convolutional	Convol
Cross Support Transfer Service	Csts
CSTS	Csts
Cyclic Redundancy Check	Crc
Decoding	Decode

CCSDS RECOMMENDED PRACTICE: FUNCTIONAL RESOURCE MODEL

Word	Abbreviation
Deencapsulation	Deencap
Delivery	Del
Delta Differential One-way Ranging	Ddor
Delta-DOR	Ddor
DOR	Dor
Earth Receive Time	Ert
Encapsulation	Encap
Encoding	Encode
End of file	Eof
Equivalent isotropically radiated power	Eirp
Extraction	Ext
Forward	Fwd
Forward CLTU	Fcltu
FR	Fr
Frame Error Control	Fec
Frame Operation Procedure	Fop
Frequency	Freq
Functional Resource	Fr
Generation	Gen
Identification	Id
Identifier	Id
Input	Inp
Internet Protocol	Ip
Invocation	Invoc
IP	Ip
Left hand circular	Lhc
Loss of lock	Lol
Low-density parity-check	Ldpc
Management	Mgmt
MAP	Map
Master Channel	Mc
Maximum	Max
MC	Mc
MD	Md
Minimum	Min
Modulation	Mod
Monitored Data	Md
Multiplexer Access Point	Map
Multiplexing	Mux
Negative acknowledgement	Nak
Noise Density	No
Non-Validated	NonVal

CCSDS RECOMMENDED PRACTICE: FUNCTIONAL RESOURCE MODEL

Word	Abbreviation
Packet	Pkt
Parameter	Param
PDU	Pdu
Physical	Phys
Physical Layer Operations Procedure	Plop
Positive	Pos
Procedure	Proc
Production	Prod
Protocol Data Unit	Pdu
Pseudo noise	Pn
Pseudo noise	Pn
Radio Frequency	Rf
Radiometric	Rm
Range	Rng
Ranging	Rng
Receive	Rcv
Received	Recvd
Receiver	Rx
Reception	Rcpt
Reed Solomon	Rs
Return	Rtn
Return All Frames	Raf
Return Channel Frames	Rcf
Return Operational Control Fields	Rocf
RF	Rf
Right hand circular	Rhc
SC	Sc
Sending	Send
Sequence	Sequ
Service Control	Sc
Service instance	Si
Service Instance Identifier	Siid
Service(s)	Svc(s)
Signal to noise ratio	Snr
SLS	Sls
Space packet	Sp
Spacecraft Identifier	Scid
Standard	Std
Status	Stat
Storage	Store
Symbol Energy	Es
Synchronization	Sync

CCSDS RECOMMENDED PRACTICE: FUNCTIONAL RESOURCE MODEL

Word	Abbreviation
Synchronizer	Sync
TC	Tc
TD	Td
TDM	Tdm
Telecommand	Tc
Telemetry	Tm
Tracking Data Message	Tdm
Transfer	Xfer
Transfer Frame Version Number	Tfvn
Transfer Service	Ts
Transmission	Xmit
Transmitter	Tx
Validated	Val
VC	Vc
Virtual Channel	Vc

ANNEX C

SECURITY, SANA, AND PATENT CONSIDERATIONS

(INFORMATIVE)

C1 SECURITY CONSIDERATIONS WITH RESPECT TO THIS RECOMMENDED PRACTICE

This Recommended Practice does not directly address security considerations. Instead, security considerations, if any, are addressed by (a) the CCSDS Recommended Standards and other standards that specify the functionality represented by the FRs defined in this Functional Resource Model Recommended Practice and/or (b) the CCSDS Recommended Standards that make use of the FRs defined in this FRM.

C2 SANA CONSIDERATIONS WITH RESPECT TO THIS RECOMMENDED PRACTICE

This Recommended Practice identifies the CCSDS FRs, defines them at the top level, and defines their interactions. The detailed definitions of the parameters, events, and directives for each of these FRs is defined in the SANA Approved Functional Resources registry at https://sanaregistry.org/r/functional_resources (reference [22]).

The SANA Functional Resources registry presents the detailed definitions in accordance with the strata defined in 3.1. In turn, each stratum lists the functional sets as defined in sections 3 through 12. For each FR defined, the FR OID is listed along with the OIDs of parameters, events, and directives. It should be noted that in addition to the OIDs, the SANA Functional Resources registry contains semantic definitions and type definitions for FRs and their parameters, events, and directives. A description of the contents of the SANA Functional Resources registry is presented in 3.4.4. Details of the FRM registry structure can be found in reference [41].

The Functional Resources Registry is a CCSDS local registry as defined per reference [42]. As such updates to the registry are managed at the CSS Area level.

C3 PATENT CONSIDERATIONS WITH RESPECT TO THIS RECOMMENDED PRACTICE

This Recommended Practice does not in itself have any patent considerations. However, there may be patent considerations with respect to the individual CCSDS Recommended Standards and other standards that specify the functionality represented by the FRs defined in this FRM. When considering implementing any of the FRs defined in this Recommended Practice, the reader is referred to the Patent Consideration annex of the respective source Recommended Standard(s).

ANNEX D

ABBREVIATIONS AND ACRONYMS

(INFORMATIVE)

<u>Term</u>	<u>Meaning</u>
AD	acceptance check and data [frames], also known as sequence-controlled user data (see reference [37])
ADD	[SCCS] Architecture Description Document
AOS	Advanced Orbiting System
ASM	attached synchronization marker
ASN.1	Abstract Syntax Notation One
AZEL	azimuth and elevation
BC	bypass of acceptance check and control [frames], also known as expedited protocol control information (see reference [37])
BCH	Bose–Chaudhuri–Hocquenghem
BD	bypass of acceptance check and data [frames], also known as expedited user data (see reference [37])
CADU	channel access data unit
CCSDS	Consultative Committee for Space Data Systems
CFDP	CCSDS File Delivery Protocol
CLCW	communications link control word
CLTU	communication link transmission unit
CM	configuration management
COP	Communications Operation Procedure
CSSA	Cross Support Services Area
CSSE	Cross Support Service Element
CSSS	Cross Support Service System
CSTS	Cross Support Transfer Service
DOR	Differential One-way Ranging
DSN	Deep Space Network
DTN	Delay-Tolerant Network
ECSS	European Cooperation for Space Standardization
EM	element management
ESLT	Earth space link terminal
FCLTU	forward communication link transmission unit
FECF	frame error control field

CCSDS RECOMMENDED PRACTICE: FUNCTIONAL RESOURCE MODEL

<u>Term</u>	<u>Meaning</u>
FF-CSTS	Forward Frame CSTS
FHEC	Frame Header Error Control
FIFO	first-in-first-out
FLF	fixed length frame
FR	functional resource
FRM	Functional Resource Model
FSH	Frame Secondary Header
GMSK	Gaussian Minimum Shift Keying
GVCID	global virtual channel identifier
IF	intermediate frequency
IOAG	Interagency Operations Advisory Group
IP	Internet Protocol
ISO	International Organization for Standardization
LDPC	low density parity check
MAP	Multiplexer Access Point
MC	master channel
MCID	master channel identifier
MD	Monitored Data [CSTS]
MIB	management information base
NE	near Earth
OCF	Operational Control Field
OID	Object Identifier
OSI	Open System Interconnection
Pc/No	carrier-power-to-noise spectral density ratio
PEDs	parameters, events, and directives
PDU	protocol data unit
PLOP	physical layer operations procedure
PM	provision management
PN	pseudo-noise
QPSK	Quadrature Phase Shift Keying
RADEC	Right Ascension and Declination
RAF	Return All Frames [SLE transfer service]
RCF	Return Channel Frames [SLE transfer service]
RF	radio frequency
ROCF	Return Operational Control Field [SLE transfer service]
SANA	Space Assigned Numbers Authority
SAP	service access point

CCSDS RECOMMENDED PRACTICE: FUNCTIONAL RESOURCE MODEL

<u>Term</u>	<u>Meaning</u>
SC[-CSTS]	service control [CSTS]
SCCS	Space Communication[s] Cross Support
SCID	spacecraft identifier
SDLP	space data link protocol
SDU	service data unit
SFW	[CSTS] Specification Framework
SLE	Space Link Extension
SLS	Space Link Session
SM	service management
SMTF	Sync-Marked Transfer Frame
SNMP	Simple Network Management Protocol
STEC	slant total electron count
TC	telecommand
TCP	transmission control protocol
TD[-CSTS]	Tracking Data [CSTS]
TDM	Tracking Data Message
TFVN	Transfer Frame Version Number
TM	telemetry
TS	transfer service
TT&C	Tracking, Telemetry, and Command
UM	utilization management
UML	Unified Modeling Language
USLP	Unified Space Data Link Protocol
VC	virtual channel
VCA	Virtual Channel Access
VCID	virtual channel identifier
VLF	variable length frame
XML	Extensible Markup Language

ANNEX E

IDENTIFIED FUTURE FUNCTIONAL RESOURCE SETS

(INFORMATIVE)

This annex lists future candidate FR Sets that have been identified as of this time, with emphasis on relevance to IOAG Service Catalog #1 and ESLTs. FR Sets associated with Space Internetworking and other services in IOAG Service Catalogs #2 and #3 will be addressed in more detail in future issues of this Recommended Practice.

E1 FUTURE CANDIDATE FR SETS BY FR STRATA

E1.1 APERTURE FR STRATUM

- Antenna Array (no CCSDS Recommended Standard);
- Optical Aperture (no CCSDS Recommended Standard).

E1.2 PHYSICAL CHANNEL FR STRATUM

- CCSDS 415 Physical Channel Transmission FR Set;
- CCSDS 415 Physical Channel Reception FR Set;
- CCSDS 141.0 Optical Communications Physical Channel Transmission FR Set;
- CCSDS 141.0 Optical Communications Physical Channel Reception FR Set.

E1.3 SYNCHRONIZATION AND CHANNEL CODING FR STRATUM

- CCSDS 131.2 Serially Concatenated Convolutional turbo Coding FR Set(s);
- CCSDS 131.3 CCSDS Over Digital Video Broadcasting – Satellite – Second Generation (DVB-S2) FR Set(s);
- CCSDS 431.1 Variable Coded Modulation Protocol FR Set(s);
- CCSDS 142.0 Optical Communications Encoding and Synchronization FR Set;
- CCSDS 142.0 Optical Communications Decoding and Synchronization FR Set.

E1.4 SPACE LINK PROTOCOL FR STRATUM

- TC Space Link Protocol Transmission FR Set (complete the remaining FRs);
- AOS Space Link Protocol Transmission FR Set (complete the remaining FRs);

- VLF Unified Space Data Link Protocol Transmission FR Set (complete the remaining FRs);
- FLF Unified Space Data Link Protocol Transmission FR Set (complete the remaining FRs);
- TM/AOS Space Link Protocol Reception FR Set (complete the remaining FRs);
- VLF Unified Space Data Link Protocol Reception FR Set (all FRs);
- FLF Unified Space Data Link Protocol Reception FR Set (complete the remaining FRs).

E1.5 SLS DATA DELIVERY PRODUCTION FR STRATUM

- CFDP File Data Production FR Set (depends if this is still supported);
- Packets File Data Transmission Production FR Set (depends if this is still supported);
- Packets File Data Reception Production FR Set (depends if this is still supported).

E1.6 OFFLINE DATA STORAGE FR STRATUM

- Return File Data Store FR Set (depends if this is still supported);
- Forward File Data Store FR Set (depends if this is still supported).

E1.7 SERVICE MANAGEMENT FUNCTIONS FR STRATUM

- Service Control FR Set.

E1.8 SPACE INTERNETWORKING FUNCTIONS FR STRATUM

- Delay Tolerant Networking FR Set(s);
- Internet Protocol Suite FR Set(s).

E2 NON-CCSDS/DE FACTO STANDARDS

E2.1 ANTENNA ARRAY

ANNEX F

MAINTENANCE OF THE FUNCTIONAL RESOURCE MODEL

(INFORMATIVE)

F1 OVERVIEW

This annex describes the procedures and tools used in the maintenance of the FRM.

F2 PROCEDURES

This annex describes the procedure to keep the SANA Functional Resources registry (reference [22]) up to date.

FRs represent the monitoring parameters, configuration parameters, and control directives of functionality described by a broad set of CCSDS Recommended Standards. Consequently, new or revised Recommended Standards typically trigger updates to the SANA Functional Resources registry. It has to be noted that already-published FR parameters, events, and directives are not replaced, but augmented with new versions. To facilitate this, the versions of FR parameters, events, and directives are encoded into the corresponding Object Identifier (OID), and procedures are documented to handle all of these cases.

The Cross Support Services Area (CSS) Area Director (AD), or some person(s) delegated by the CSS AD, performs and authorizes SANA Functional Resources registry updates. Before changes of the SANA Functional Resources registry are actually published, the changes are subject to a CCSDS-wide review to make sure they are adequate, correct, and of good quality. In theory, WGs authoring a CCSDS Recommended Standard could perform an update of the corresponding FR(s); however, to date this is not a common practice.

Finally, the SANA Functional Resources registry is updated by the CSS Area by means of an XML file, capturing all authored and updated FRs. The SANA operator transforms the provided XML file into the web based FR representation available the SANA (reference [22]).