

# CCSDS Historical Document

This document's Historical status indicates that it is no longer current. It has either been replaced by a newer issue or withdrawn because it was deemed obsolete. Current CCSDS publications are maintained at the following location:

<http://public.ccsds.org/publications/>



**CCSDS**

The Consultative Committee for Space Data Systems

---

## Recommendation for Space Data System Standards

# SPACECRAFT ONBOARD INTERFACE SERVICES— HIGH DATA RATE 3GPP AND WI-FI LOCAL AREA COMMUNICATIONS

**RECOMMENDED STANDARD**

**CCSDS 883.0-B-1**

**BLUE BOOK**

**February 2022**



## Recommendation for Space Data System Standards

**SPACECRAFT ONBOARD  
INTERFACE SERVICES—  
HIGH DATA RATE 3GPP AND  
WI-FI LOCAL AREA  
COMMUNICATIONS**

**RECOMMENDED STANDARD**

**CCSDS 883.0-B-1**

**BLUE BOOK**  
February 2022

## AUTHORITY

Issue:	Recommended Standard, Issue 1
Date:	February 2022
Location:	Washington, DC, USA

This document has been approved for publication by the Management Council of the Consultative Committee for Space Data Systems (CCSDS) and represents the consensus technical agreement of the participating CCSDS Member Agencies. The procedure for review and authorization of CCSDS documents is detailed in *Organization and Processes for the Consultative Committee for Space Data Systems* (CCSDS A02.1-Y-4), and the record of Agency participation in the authorization of this document can be obtained from the CCSDS Secretariat at the email address below.

This document is published and maintained by:

CCSDS Secretariat  
National Aeronautics and Space Administration  
Washington, DC, USA  
Email: [secretariat@mailman.ccsds.org](mailto:secretariat@mailman.ccsds.org)

## STATEMENT OF INTENT

The Consultative Committee for Space Data Systems (CCSDS) is an organization officially established by the management of its members. The Committee meets periodically to address data systems problems that are common to all participants, and to formulate sound technical solutions to these problems. Inasmuch as participation in the CCSDS is completely voluntary, the results of Committee actions are termed **Recommended Standards** and are not considered binding on any Agency.

This **Recommended Standard** is issued by, and represents the consensus of, the CCSDS members. Endorsement of this **Recommendation** is entirely voluntary. Endorsement, however, indicates the following understandings:

- o Whenever a member establishes a CCSDS-related **standard**, this **standard** will be in accord with the relevant **Recommended Standard**. Establishing such a **standard** does not preclude other provisions which a member may develop.
- o Whenever a member establishes a CCSDS-related **standard**, that member will provide other CCSDS members with the following information:
  - The **standard** itself.
  - The anticipated date of initial operational capability.
  - The anticipated duration of operational service.
- o Specific service arrangements shall be made via memoranda of agreement. Neither this **Recommended Standard** nor any ensuing **standard** is a substitute for a memorandum of agreement.

No later than five years from its date of issuance, this **Recommended Standard** will be reviewed by the CCSDS to determine whether it should: (1) remain in effect without change; (2) be changed to reflect the impact of new technologies, new requirements, or new directions; or (3) be retired or canceled.

In those instances when a new version of a **Recommended Standard** is issued, existing CCSDS-related member standards and implementations are not negated or deemed to be non-CCSDS compatible. It is the responsibility of each member to determine when such standards or implementations are to be modified. Each member is, however, strongly encouraged to direct planning for its new standards and implementations towards the later version of the Recommended Standard.

## **FOREWORD**

Attention is drawn to the possibility that some of the elements of this document may be the subject of patent rights. CCSDS has processes for identifying patent issues and for securing from the patent holder agreement that all licensing policies are reasonable and non-discriminatory. However, CCSDS does not have a patent law staff, and CCSDS shall not be held responsible for identifying any or all such patent rights.

Through the process of normal evolution, it is expected that expansion, deletion, or modification of this document may occur. This Recommended Standard is therefore subject to CCSDS document management and change control procedures, which are defined in *Organization and Processes for the Consultative Committee for Space Data Systems* (CCSDS A02.1-Y-4). Current versions of CCSDS documents are maintained at the CCSDS Web site:

<http://www.ccsds.org/>

Questions relating to the contents or status of this document should be sent to the CCSDS Secretariat at the email address indicated on page i.

At time of publication, the active Member and Observer Agencies of the CCSDS were:

Member Agencies

- Agenzia Spaziale Italiana (ASI)/Italy.
- Canadian Space Agency (CSA)/Canada.
- Centre National d'Etudes Spatiales (CNES)/France.
- China National Space Administration (CNSA)/People's Republic of China.
- Deutsches Zentrum für Luft- und Raumfahrt (DLR)/Germany.
- European Space Agency (ESA)/Europe.
- Federal Space Agency (FSA)/Russian Federation.
- Instituto Nacional de Pesquisas Espaciais (INPE)/Brazil.
- Japan Aerospace Exploration Agency (JAXA)/Japan.
- National Aeronautics and Space Administration (NASA)/USA.
- UK Space Agency/United Kingdom.

Observer Agencies

- Austrian Space Agency (ASA)/Austria.
- Belgian Science Policy Office (BELSPO)/Belgium.
- Central Research Institute of Machine Building (TsNIIMash)/Russian Federation.
- China Satellite Launch and Tracking Control General, Beijing Institute of Tracking and Telecommunications Technology (CLTC/BITTT)/China.
- Chinese Academy of Sciences (CAS)/China.
- China Academy of Space Technology (CAST)/China.
- Commonwealth Scientific and Industrial Research Organization (CSIRO)/Australia.
- Danish National Space Center (DNSC)/Denmark.
- Departamento de Ciência e Tecnologia Aeroespacial (DCTA)/Brazil.
- Electronics and Telecommunications Research Institute (ETRI)/Korea.
- European Organization for the Exploitation of Meteorological Satellites (EUMETSAT)/Europe.
- European Telecommunications Satellite Organization (EUTELSAT)/Europe.
- Geo-Informatics and Space Technology Development Agency (GISTDA)/Thailand.
- Hellenic National Space Committee (HNSC)/Greece.
- Hellenic Space Agency (HSA)/Greece.
- Indian Space Research Organization (ISRO)/India.
- Institute of Space Research (IKI)/Russian Federation.
- Korea Aerospace Research Institute (KARI)/Korea.
- Ministry of Communications (MOC)/Israel.
- Mohammed Bin Rashid Space Centre (MBRSC)/United Arab Emirates.
- National Institute of Information and Communications Technology (NICT)/Japan.
- National Oceanic and Atmospheric Administration (NOAA)/USA.
- National Space Agency of the Republic of Kazakhstan (NSARK)/Kazakhstan.
- National Space Organization (NSPO)/Chinese Taipei.
- Naval Center for Space Technology (NCST)/USA.
- Netherlands Space Office (NSO)/The Netherlands.
- Research Institute for Particle & Nuclear Physics (KFKI)/Hungary.
- Scientific and Technological Research Council of Turkey (TUBITAK)/Turkey.
- South African National Space Agency (SANSA)/Republic of South Africa.
- Space and Upper Atmosphere Research Commission (SUPARCO)/Pakistan.
- Swedish Space Corporation (SSC)/Sweden.
- Swiss Space Office (SSO)/Switzerland.
- United States Geological Survey (USGS)/USA.

**DOCUMENT CONTROL**

<b>Document</b>	<b>Title</b>	<b>Date</b>	<b>Status</b>
CCSDS 883.0-B-1	Spacecraft Onboard Interface Services—High Data Rate 3GPP and Wi-Fi Local Area Communications, Recommended Standard, Issue 1	February 2022	Original issue

## CONTENTS

<u>Section</u>	<u>Page</u>
<b>1 INTRODUCTION</b> .....	<b>1-1</b>
1.1 PURPOSE.....	1-1
1.2 SCOPE.....	1-1
1.3 APPLICABILITY.....	1-2
1.4 RATIONALE.....	1-2
1.5 DOCUMENT STRUCTURE.....	1-3
1.6 CONVENTIONS.....	1-3
1.7 ACRONYMS.....	1-4
1.8 REFERENCES.....	1-4
<b>2 OVERVIEW</b> .....	<b>2-1</b>
2.1 EXECUTIVE SUMMARY.....	2-1
2.2 MISSION DESIGN DRIVERS.....	2-3
2.3 WIRELESS COMMUNICATION RELATIVE MOTION, RANGE, AND DATA RATES.....	2-5
2.4 STANDARDS EVOLUTION FOR FUTURE ADVANCED CAPABILITY.....	2-5
2.5 IEEE 802.11 SERIES TO 3GPP SERIES STANDARDS COMPARISON.....	2-15
2.6 SPECTRUM EVOLUTION PATH FOR FUTURE MISSIONS.....	2-20
2.7 NETWORK MANAGEMENT.....	2-23
<b>3 WIRELESS PROXIMITY NETWORKING COMMUNICATIONS     RECOMMENDED STANDARDS</b> .....	<b>3-1</b>
3.1 OVERVIEW.....	3-1
3.2 FREQUENCY COORDINATION.....	3-1
3.3 IEEE 802.11 STANDARDS.....	3-4
3.4 3GPP STANDARDS.....	3-6
<b>ANNEX A IMPLEMENTATION CONFORMANCE STATEMENT     PROFORMA (NORMATIVE)</b> .....	<b>A-1</b>
<b>ANNEX B SECURITY, SANA, PATENT CONSIDERATIONS     (INFORMATIVE)</b> .....	<b>B-1</b>
<b>ANNEX C WIRELESS PROXIMITY NETWORK     COMMUNICATIONS TECHNOLOGIES (INFORMATIVE)</b> .....	<b>C-1</b>
<b>ANNEX D QCI – QOS CLASS IDENTIFIER OVERVIEW     (INFORMATIVE)</b> .....	<b>D-1</b>
<b>ANNEX E INFORMATIVE REFERENCES (INFORMATIVE)</b> .....	<b>E-1</b>
<b>ANNEX F ABBREVIATIONS AND ACRONYMS (INFORMATIVE)</b> .....	<b>F-1</b>

**CONTENTS (continued)**

<u>Section</u>	<u>Page</u>
<b>ANNEX G TDD, FDD, AND LTE CONSIDERATIONS (INFORMATIVE)</b> .....	<b>G-1</b>
<b>ANNEX H PROPOSED FUTURE STANDARDIZATION ACTIVITIES (INFORMATIVE)</b> .....	<b>H-1</b>

Figure

1-1 Bit Numbering Convention.....	1-3
2-1 Standards Development and Device Availability Timeline .....	2-9
2-2 Standards-Based Proximity Communications—Device Data Rate vs. Range .....	2-9
2-3 Standards-Based Proximity Communications—Power Consumption .....	2-10
2-4 Standards-Based Proximity Communications—Criticality vs. Range .....	2-10
2-5 3GPP User Plane CCSDS Adaptation Profile: DTN/BP End-to-End .....	2-24
2-6 IEEE 802.11 Wi-Fi CCSDS Adaptation Profile: DTN/BP End-to-End.....	2-25
2-7 3GPP User Plane CCSDS Adaptation Profile: IP over CCSDS.....	2-26
2-8 IEEE 802.11 Wi-Fi CCSDS Adaptation Profile: IP-over-CCSDS (Near-Earth) .....	2-27
2-9 IEEE 802.11 Wi-Fi CCSDS Adaptation Profile, BP for Long Haul Links, TCP/IP Requires BP Store-and-Forward Gateway.....	2-28
C-1 Basic 3GPP Long Term Evolution (LTE) Architecture .....	C-6
C-2 3GPP Control User Plane Split.....	C-11
D-1 Scope of Standardized QCI Model for Client/server and Peer Communication .....	D-2

Table

1-1 Wireless Communications Coverage Ranges and Data Rates.....	1-2
2-1 Space Exploration Mission Activities .....	2-4
2-2 Wireless Technologies Key Performance Indicators Assessment.....	2-13
2-3 Capability-Driven Standards Selection.....	2-15
3-1 Recommended Frequency Bands for Communications in the Lunar Region .....	3-2
3-2 Recommended Frequency Bands for RNSS or RDSS Applications in the Lunar Vicinity .....	3-3
3-3 Limitations Applicable to the Recommended Lunar Surface Communication Frequencies .....	3-3
B-1 Wireless Proximity Networking Identifiers.....	B-2
C-1 3GPP LTE and 5G Capabilities by Release .....	C-8
D-1 QoS Class Identifier Definitions for the Space Domain.....	D-1
D-2 Standardized QCI Characteristics.....	D-5
G-1 LTE, FDD, and TDD Considerations .....	G-1
H-1 Roadmap for Future Standardization Activities .....	H-1

## **1 INTRODUCTION**

### **1.1 PURPOSE**

This document provides a CCSDS Recommended Standard for mobile High Data Rate Wireless Proximity Network Communications architecture, protocols, and communication standards in support of activities associated with space missions. Relevant technical background information can be found in *Wireless Network Communications Overview for Space Mission Operations* (reference [E1]).

This Recommended Standard is a Utilization Profile that defines the best option(s) available for interoperable mobile wireless proximity network communications, using current commercial wireless technologies, in the support of space exploration and operations activities. While these standards are named ‘network’, their functionality is defined at the ISO Basic Reference Model (BRM) Data Link and Physical Layers. They offer ‘network’ services only insofar as they support a Data Link Layer mesh of multiple access points. These commercial standards are suitable for ‘proximity’ communication in the range of 0-100 km for maximum hop-by-hop distances, and with a low velocity and acceleration between the communicating objects. For longer range communications or for higher Doppler dynamics, such as from surface elements to an orbiting asset, the Proximity-1 protocol, CCSDS 211.0-B-6 is recommended.

A general issue that must be addressed is coordinated RF spectrum allocation for space agency (e.g., lunar, Martian) exploration missions. The Physical Layer frequencies that the source standards have adopted may, in many cases, not be suitable for use in space, particularly in the Shielded Zone of the Moon (SZM).

When these standards are deployed for space missions the actual Physical Layer frequency assignments must be made by space agencies in coordination with their liaisons within Space Frequency Coordination Group (SFCG) (references [33] and [42]), with their spectrum personnel, and when needed, with ITU (references [34], [37], [38], [39]) and applicable Radio Astronomy representatives for conclusiveness.

### **1.2 SCOPE**

This Recommended Standard is intended to provide a technical basis for selecting and adopting relevant approaches for fixed and mobile High Data Rate 3GPP and Wi-Fi Local Area Communications architectures, protocols, and communication standards for CCSDS Member Agencies.

#### **1.2.1 WIRELESS COVERAGE RANGES AND DATA RATES**

Wireless communications coverage ranges and data rates, at the time of document publication, are generically classified as shown below in table 1-1. These ranges are characterized from short to very long within the context of nearby (0-100 km) communications.

**Table 1-1: Wireless Communications Coverage Ranges and Data Rates**

<b>Range Class</b>	<b>Wireless Range</b>	<b>Data Rate Class</b>	<b>Data Rate</b>
<b>Short range</b>	Less than 100 m	<b>Low rate</b>	Less than 1 Mb/s
<b>Medium range</b>	100 m to 1 km	<b>Medium rate</b>	1 Mb/s to 1 Gb/s
<b>Long range</b>	1 km to 10 km	<b>High rate</b>	1 Gb/s to 100 Gb/s
<b>Very Long range</b>	Up to ~100 km	<b>Very High rate</b>	Greater than 100 Gb/s

### **1.3 APPLICABILITY**

This Recommended Standard identifies architectures, protocols, and standards that enable interoperable High Data Rate RF Wireless Proximity Network Communications in support of CCSDS Agencies Exploration Missions. The standards herein are applicable to internal and external proximity wireless network communications, specifically in support of human space flight, or robotic, on-board and visiting-vehicle communications links, robotic and crewed EVA sorties, and surface-to-surface operations. These standards are only suitable for these close-range proximity applications which are subject to low-rate Doppler effects. These standards are not suitable for surface to orbital vehicle proximity communications or other links where the relative velocities or relative accelerations are substantially higher. Ultra-wide Band (UWB) and Free Space Optic High Data Rate Wireless Proximity Network Communications are outside the scope of this Standard.

NOTE – This book covers interoperability recommendations for Wi-Fi and 3GPP architectures. It does not address recommendations specific to deployments in unique mission environments. It is forward work for the implementing engineer to address, on a case-by-case basis, issues such as band selection, antenna selection, antenna placement, antenna elevation, cell site planning, network loading, mission criticality, backhaul, etc. to provide desired coverage and service for a specific mission.

NOTE – Inclusion of any specific wireless technology does not constitute any endorsement, expressed or implied, by CCSDS agencies.

### **1.4 RATIONALE**

Mission managers, along with engineers and developers, are faced with a plethora of wireless communication choices, both standards-based and proprietary. A CCSDS High Data Rate RF Wireless Proximity Network Communications Recommended Standard will provide a basis for open standards-based RF wireless communication architectures and protocols for mission design consideration.

## 1.5 DOCUMENT STRUCTURE

Section 2 provides an overview summary of the recommended two major wireless network proximity communications standards paths: the IEEE 802.11 standards (Wi-Fi) and the 3rd Generation Partnership Project (3GPP) (LTE, 5G and beyond) standards.

Section 3 provides a normative description for the recommendations for high data rate proximity wireless network communications.

Annex C Wireless Proximity Network Communications Technologies provides a technical overview of the two wireless standards recommended in this documents: IEEE 802.11 Wi-Fi and 3GPP Long-Term Evolution (LTE). Relevant additional background is available in reference [E1] and in the annexes of this document as enumerated below.

- annex A, Implementation Conformance Statement Proforma;
- annex B, Security, SANA, Patent Considerations;
- annex D, QCI – QoS Class Identifier Overview;
- annex E, Informative References;
- annex F, Abbreviations and Acronyms;
- annex G, TDD, FDD, and LTE Considerations;
- annex H, Proposed Future Standardization Activities.

## 1.6 CONVENTIONS

### 1.6.1 BIT NUMBERING

In this document, the following convention is used to identify each bit in an  $N$ -bit field. The first bit in the field is defined to be ‘bit  $N-1$ ’; the following bit is defined to be ‘bit  $N-2$ ’, and so on up to ‘bit 0’, as shown in figure 1-1.

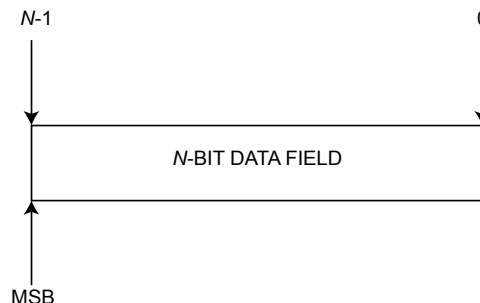

**Figure 1-1: Bit Numbering Convention**

In accordance with modern data communications practice, spacecraft data fields are often grouped into 8-bit ‘bytes’, which conform to the above convention.

## **1.6.2 NOMENCLATURE**

### **1.6.2.1 Normative Text**

The following conventions apply for the normative specifications in this Recommended Experimental Standard:

- a) the words ‘shall’ and ‘must’ imply a binding and verifiable specification;
- b) the word ‘should’ implies an optional, but desirable, specification;
- c) the word ‘may’ implies an optional specification;
- d) the words ‘is’, ‘are’, and ‘will’ imply statements of fact.

NOTE – These conventions do not imply constraints on diction in text that is clearly informative in nature.

### **1.6.2.2 Informative Text**

In the normative section of this document, informative text is set off from the normative specifications either in notes or under one of the following subsection headings:

- Overview;
- Background;
- Rationale;
- Discussion.

## **1.7 ACRONYMS**

A glossary of terms and common acronyms are provided in annex F.

## **1.8 REFERENCES**

The following publications contain provisions which, through reference in this text, constitute provisions of this document. At the time of publication, the editions indicated were valid. All publications are subject to revision, and users of this document are encouraged to investigate the possibility of applying the most recent editions of the publications indicated below. The CCSDS Secretariat maintains a register of currently valid CCSDS publications.

- [1] *IEEE Standard for Information Technology—Telecommunications and Information Exchange Between Systems Local and Metropolitan Area Networks—Specific Requirements—Part 11: Wireless LAN Medium Access Control (MAC) and Physical Layer (PHY) Specifications*. IEEE Std 802.11-2020. New York: IEEE, 2020.

- [2] *IEEE Standard for Information Technology—Telecommunications and Information Exchange between Systems - Local and Metropolitan Area Networks—Specific Requirements—Part 11: Wireless LAN Medium Access Control (MAC) and Physical Layer (PHY) Specifications Amendment 2: Sub 1 GHz License Exempt Operation.* IEEE Std 802.11ah-2016. New York: IEEE, 2017.
- [3] *5GS Roaming Guidelines.* Version 3.0. GSMA NG.113. London: GSMA, November 2020.
- [4] *3rd Generation Partnership Project; Technical Specification Group Services and System Aspects; Architecture Enhancements for Control and User Plane Separation of EPC Nodes; Stage 2.* Release 16. 3GPP Technical Specification, 3GPP TS 23.214 V16.2.0. Sophia Antipolis: 3GPP, September 2020.
- [5] *3rd Generation Partnership Project; Technical Specification Group Core Network and Terminals; Numbering, Addressing and Identification.* Release 17. 3GPP Technical Specification, 3GPP TS 23.003 V17.0.0. Sophia Antipolis: 3GPP, December 2020.
- [6] *3rd Generation Partnership Project; Technical Specification Group Core Network and Terminals; Interface between the Control Plane and the User Plane Nodes; Stage 3.* Release 16. 3GPP Technical Specification, 3GPP TS 29.244 V16.6.0. Sophia Antipolis: 3GPP, December 2020.
- [7] *3rd Generation Partnership Project; Technical Specification Group Radio Access Network; Evolved Universal Terrestrial Radio Access (E-UTRA); User Equipment (UE) Radio Transmission and Reception.* Release 16. 3GPP Technical Specification, 3GPP TS 36.101 V16.7.0. Sophia Antipolis: 3GPP, September 2020.
- [8] *3rd Generation Partnership Project; Technical Specification Group Radio Access Network; Study on Licensed-Assisted Access to Unlicensed Spectrum.* Release 13. 3GPP Technical Report, 3GPP TR 36.889 V13.0.0. Sophia Antipolis: 3GPP, June 2015.
- [9] *3rd Generation Partnership Project; Technical Specification Group Services and System Aspects; Policy and Charging Control Architecture.* Release 16. 3GPP Technical Specification, 3GPP TS 23.203 V16.2.0. Sophia Antipolis: 3GPP, December 2019.
- [10] *Reconfigurable Radio Systems (RRS); Information Elements and Protocols for the Interface between LSA Controller (LC) and LSA Repository (LR) for Operation of Licensed Shared Access (LSA) in the 2 300 MHz - 2 400 MHz Band.* ETSI Technical Specification, ETSI TS 103 379 V1.1.1. Sophia Antipolis: ETSI, January 2017.
- [11] *LTE and EPC Roaming Guidelines.* Version 18.0. GSMA IR.88. London: GSMA, June 2018.

- [12] *3rd Generation Partnership Project; Technical Specification Group Radio Access Network; Evolved Universal Terrestrial Radio Access Network (E-UTRAN); SI Application Protocol (SIAP)*. Release 16. 3GPP Technical Specification, 3GPP TS 36.413 V16.3.0. Sophia Antipolis: 3GPP, September 2020.
- [13] *3rd Generation Partnership Project; Technical Specification Group Services and System Aspects; Network Sharing; Architecture and Functional Description*. Release 16. 3GPP Technical Specification, 3GPP TS 23.251 V16.0.0. Sophia Antipolis: 3GPP, July 2020.
- [14] *3rd Generation Partnership Project; Technical Specification Group Services and System Aspects; 3GPP System Architecture Evolution (SAE); Security Architecture*. Release 16. 3GPP Technical Specification, 3GPP TS 33.401 V16.3.0. Sophia Antipolis: 3GPP, July 2020.
- [15] *3rd Generation Partnership Project; Technical Specification Group Services and System Aspects; Network Architecture*. Release 16. 3GPP Technical Specification, 3GPP TS 23.002 V16.0.0. Sophia Antipolis: 3GPP, July 2020.
- [16] *3rd Generation Partnership Project; Technical Specification Group Radio Access Network; Evolved Universal Terrestrial Radio Access (E-UTRA); LTE Physical Layer; General Description*. Release 16. 3GPP Technical Specification, 3GPP TS 36.201 V16.0.0. Sophia Antipolis: 3GPP, June 2020.
- [17] *The International Identification Plan for Public Networks and Subscriptions*. Series E: Overall Network Operation, Telephone Service, Service Operation and Human Factors: International Operation—Maritime Mobile Service and Public Land Mobile Service, ITU-T E.212. Geneva: ITU, November 2016.
- [18] *The International Telecommunication Charge Card*. Series E: Overall Network Operation, Telephone Service, Service Operation and Human Factors: International Operation—General Provisions concerning Administrations, ITU-T E.118. Geneva: ITU, May 2006.
- [19] *3rd Generation Partnership Project; Technical Specification Group Services and System Aspects; Study on Using Satellite Access in 5G; Stage 1*. Release 16. 3GPP Technical Report, 3GPP TR 22.822 V16.0.0. Sophia Antipolis: 3GPP, June 2018.
- [20] *3rd Generation Partnership Project; Technical Specification Group Radio Access Network; Study on New Radio (NR) to Support Non-Terrestrial Networks*. Release 15. 3GPP Technical Report, 3GPP TR 38.811 V15.4.0. Sophia Antipolis: 3GPP, September 2020.
- [21] *The International Public Telecommunication Numbering Plan*. Series E: Overall Network Operation, Telephone Service, Service Operation and Human Factors: International Operation—Numbering Plan of the International Telephone Service, ITU-T E.164. Geneva: ITU, November 2010.

- [22] *IEEE Standard for Local and Metropolitan Area Networks--Port-Based Network Access Control*. IEEE Std 802.1X-2020. Piscataway, New Jersey: IEEE, February 2020.
- [23] C. Perkins, et al. *Multicast Considerations over IEEE 802 Wireless Media*. Expired. Internet-Draft draft-ietf-mboned-ieee802-mcast-problems-11. Reston, Virginia: ISOC, December 11, 2019.
- [24] *3rd Generation Partnership Project; Technical Specification Group Services and System Aspects; Multimedia Broadcast/Multicast Service (MBMS); Architecture and Functional Description*. Release 16. 3GPP Technical Specification, 3GPP TS 23.246 V16.1.0. Sophia Antipolis: 3GPP, September 2019.
- [25] *3rd Generation Partnership Project; Technical Specification Group Radio Access Networks; eMBMS Enhancements for LTE*. Release 14. 3GPP Technical Report, 3GPP TR 36.743 V0.1.0. Sophia Antipolis: 3GPP, May 2016.
- [26] *3rd Generation Partnership Project; Technical Specification Group Radio Access Network; Evolved Universal Terrestrial Radio Access (E-UTRA); Study on LTE-Based 5G Terrestrial Broadcast*. Release 16. 3GPP Technical Report, 3GPP TR 36.776 V16.0.0. Sophia Antipolis: 3GPP, March 2019.
- [27] *WPA3™ Specification*. Version 3.0. Austin, Texas: Wi-Fi Alliance®, December 2020.
- [28] *3rd Generation Partnership Project; Technical Specification Group Services and System Aspects Study on Management and Orchestration Aspects with Integrated Satellite Components in a 5G Network*. Release 17. 3GPP Technical Report, 3GPP TR 28.808 V1.0.0. Sophia Antipolis: 3GPP, December 2020.
- [29] *External Payload Interface Requirements Document*. Rev-L. International Space Station Program, SSP 57003. N.p., September 2015.
- [30] *CPE WAN Management Protocol*. Issue 1 Amendment 6. Broadband Forum Technical Report [CWMP Version: 1.4], TR-069. Fremont, California: The Broadband Forum, March 2018. [https://www.broadband-forum.org/download/TR-069\\_Amendment-6.pdf](https://www.broadband-forum.org/download/TR-069_Amendment-6.pdf)
- [31] *IEEE Standard for Information Technology—Telecommunications and Information Exchange between Systems—Local and Metropolitan Area Networks—Specific Requirements—Part 11: Wireless LAN Medium Access Control (MAC) and Physical Layer (PHY) Specifications: Amendment 6: Medium Access Control (MAC) Security Enhancements*. Superseded. IEEE 802.11i-2004. Piscataway, New Jersey: IEEE, 2004.
- [32] *3rd Generation Partnership Project; Technical Specification Group Services and System Aspects; Single Radio Voice Call Continuity (SRVCC); Stage 2*. Release 16. 3GPP Technical Specification, 3GPP TS 23.216 V16.4.0. Sophia Antipolis: 3GPP, March 2020.

- [33] *Communication Frequency Allocations and Sharing in the Lunar Region*. Space Frequency Coordination Group Recommendation, SFCG 32-2R3. Darmstadt, Germany: SFCG, 10 December 2021.
- [34] *Preferred Frequency Bands for Radio Astronomical Measurements*. RA Series, ITU-R RA.314-10. Geneva: ITU, June 2020.
- [35] *3rd Generation Partnership Project; Technical Specification Group Radio Access Network; Requirements for Evolved UTRA (E-UTRA) and Evolved UTRAN (E-UTRAN)*. Release 9. 3GPP Technical Report, 3GPP TR 25.913 V9.0.0. Sophia Antipolis: 3GPP, December 2009.
- [36] *3rd Generation Partnership Project; Technical Specification Group Radio Access Network; Study on Channel Model for Frequencies from 0.5 to 100 GHz*. Release 16. 3GPP Technical Report, 3GPP TR 38.901 V16.1.0. Sophia Antipolis: 3GPP, December 2019.
- [37] “Radio Regulations 2020.” 2020. ITU.  
<https://www.itu.int/en/myitu/Publications/2020/09/02/14/23/Radio-Regulations-2020>.
- [38] *Protection of Frequencies for Radioastronomical Measurements in the Shielded Zone of the Moon*. RA Series, ITU-R RA.479-5. Geneva: ITU, 2003.
- [39] “Radio Astronomy in the Shielded Zone of the Moon.” Article 22, Section V in *Articles*. Vol. 1 of *Radio Regulations*. Edition of 2020. 4 vols. Geneva: ITU, 2020.
- [40] *LTE; Evolved Universal Terrestrial Radio Access (E-UTRA); User Equipment (UE) Conformance Specification; Radio Transmission and Reception; Part 1: Conformance Testing*. ETSI TS 136 521-1 V15.2.0 (2018-10). Sophia-Antipolis: ETSI, 2018.
- [41] *3rd Generation Partnership Project; Technical Specification Group Radio Access Network; Evolved Universal Terrestrial Radio Access (E-UTRA); User Equipment (UE) Conformance Specification; Radio Transmission and Reception; Part 1: Conformance Testing*. Release 16. 3GPP Technical Specification, 3GPP TS 36.521-1 V16.9.0 (2021-06). Sophia Antipolis: 3GPP, June 2021.
- [42] *Frequency Assignment Guidelines for Communications in the Mars Region*. Space Frequency Coordination Group Recommendation, SFCG 22-1R4. Darmstadt, Germany: SFCG, 10 December 2021.

## 2 OVERVIEW

### 2.1 EXECUTIVE SUMMARY

Communication options and recommendations for current commercial standards in support of space exploration and planetary surface operation within the range 0-100 Km are summarized. The standards herein are applicable to internal and external proximity wireless network communications, specifically in support of human space flight, or robotic, on-board and visiting-vehicle communications links, robotic and crewed EVA sorties, payload communications and surface-to-surface operations. These standards are only suitable for these close-range proximity applications with low velocities and acceleration between the communicating objects. Communications back to Earth from in and around any landed or orbiting assets will require use of other ‘long haul’ CCSDS Data Link Layer protocols or the longer distance Proximity-1 protocol which is compatible with higher relative velocities and accelerations.

The goal of the recommendations is to provide summary information and guidance to agency decision-makers for system down-select purposes, accounting for projected timelines for technology evolution. Lower data rate applications can be supported by the wireless proximity network communications standards and architectures recommended in this document, although a mission designer may consider lower Space, Weight, and Power (SWaP) solutions. The Wireless Proximity Network Communications Use Cases annex in reference [E1] provides a summary of design-driving and priority exploration use cases as provided by CCSDS International Space Agency members.

This document references and recommends two major standards paths: the IEEE 802.11 standards and the 3GPP standards. IEEE 802.11 (Wi-Fi) standards follow a set of standards sequences, sometimes splitting into multiple paths, with corresponding occasional roll-ups of standards and technologies into one single standard. The 3GPP standards include the modern LTE standard, starting at 3GPP Release 8, that is the basis of modern mobile (cellular smartphone) Internet Protocol (IP)-based communications. LTE has undergone many stages of evolution; 3GPP Release 12 and above are suggested in these recommendations, and the 3GPP roadmap, currently at Release 17, is projected for the next decade. Limitations of the present recommendations and future evolution is summarized in 2.4.

It is recommended that responsible space agency spectrum personnel initiate additional spectrum assignments from the SFCG: *with improper spectrum allocation, the recommendations in this document are not applicable.* When the Shielded Zone of the Moon (SZM) is concerned, space agency personnel also need to coordinate with applicable Radio Astronomy representatives. The peak network data rates that are possible with the wireless network technology standards considered in these recommendations range from several hundred Mb/s to 100+ Gb/s per base station. Thus a wired backbone network can easily be the limiter of network capacity. For full expansion capability, upgradable backbone network technologies within a habitat, station, or vehicle, such as optical fiber (~1 Tb/s eventual capacity), should be considered.

Relevant technical background information can be found in *Wireless Network Communications Overview for Space Mission Operations* (reference [E1]). The Wireless Proximity Network Communications Use Cases annex in reference [E1] provides a summary of design-driving and priority exploration use cases as provided by CCSDS International Space Agency members.

A primary aim of the family of standards recommended in this document is to support exploration-class missions in a wide range of operating environments. In the case of the 3GPP standards, which already support planetary-scale networks on Earth, LTE networks are a 3GPP evolution that provides for wide scale, high-speed operation at multiple range scales, in topographies ranging from flat to highly mountainous, and over a wide range of ground/regolith types from areas with oceans and trees to rocky deserts while also supporting indoor operations. The extensive requirements and capabilities for which LTE is designed is described in reference [35].

Additionally, all 3GPP standards involved detailed modelling for both protocols and channel characteristics, and the present extensive series of channel models used in developing 3GPP technical standards, up to and including 5G, is available in reference [36].

The resulting range of LTE capabilities, with a path to the even more extensive set of mission-critical capabilities of 5G, allows for 3GPP standards to be deployed to meet an extremely wide range of applications and planetary surface environments, easily being adaptable to spaceflight-specific cases (references [35] and [36]). Correspondingly, IEEE 802.11-series communication is designed for a wide range of increasingly mission-critical applications for short-range indoors networks, with a relatively low mass and system complexity, albeit not having the wide depth of outdoor/long-range surface capabilities found in the 3GPP series.

- 1) 3GPP standards have been driven by wide-area communications requirements from their inception, using a multi-scale cellular approach, and all 3GPP implementations are capable of a wide class of multiple-node communications, including cooperative inter-node multipoint, sophisticated dynamic interference management, carrier aggregation, and many more techniques designed for large multi-node planetary-scale distributed networks to accommodate terrestrial 3GPP design drivers.
- 2) Channel models depend on environment and deployment architecture (see references [36], [E23], [E24], and [E25]). LTE frame structure and timing Inter-Symbol Interference (ISI) protection scales to multipath environments compatible with ~100 km link distances in mountainous terrains on Earth and will easily address most reasonable planetary, lunar, and other complex surface topography deployments (references [35] and [36]). Delay spread significantly below 1/15 ms has no impact on LTE symbol decoding. This supports a path-spread of 10 km for received multipath components. Channel models are studied in depth in IEEE, 3GPP, and ITU processes, easily supporting the relatively small networks envisioned for spaceflight networks (see references [1], [2], [23], [16], [20], [25], [26], [35], [36], and [E18]). It may be noted that references [E23], [E24], and [E25] are terrestrial-related analog studies and that additional information and verification are necessary to ensure suitability for extraterrestrial communications.

Additional technical background information is contained in *Wireless Network Communications Overview for Space Mission Operations* (reference [E1]).

- 3) Modern 3GPP wireless standards are extremely resistant to multipath ISI but also to Frequency-Selective Fading (FSF) from delay and Doppler spread via the employment of Orthogonal Frequency Division Multiplexing (OFDM) (encode around), Orthogonal Frequency-Division Multiple Access (OFDMA) (schedule around), and channel-state feedback (nominally in excess of 100 Hz) for both equalization and scheduling. In general, the large number of sub-carriers means that the carrier channel bandwidth is much larger than the sub-carrier channel width, resulting in independent channel fading and channel gain on a spectral scale far smaller than the carrier. IEEE 802.11 networks have recently evolved to use many of the same techniques as 4G/LTE and 5G 3GPP networks. Additional technical background regarding multi-channel communications is contained in *Wireless Network Communications Overview for Space Mission Operations* (reference [E1]).
- 4) The selected protocols employ several signal structure and timing techniques to combat and even exploit multipath. Most of these techniques are inherent and cognitively managed in commercially available implementations. An additional protocol feature that significantly improves multipath performance is the use of space-time encoding via combinations of single-in/out and multiple in/out (SIMO, MISO, or MIMO) antenna architectures, and the effectiveness of this control depends heavily on the system-level implementation of cables, antennas, and coverage areas. Designers of deployments in high-multipath environments can therefore suffer coverage ‘dead zones’ if the implementation does not connect each radio to multiple antennas with adequate spatial separation and with coverage overlap.
- 5) Multipath, in a wide range of planetary, lunar, and other exploration surface environments, therefore produces ISI and Doppler spread mobility FSF channel characteristics that will generally result in no impact for LTE due to OFDM, OFDMA, and SC-FDMA modulations over the LTE 15 kHz sub-carrier spacing with 600-1,200 sub-carriers for 10-20 MHz of deployed bandwidth. Both LTE and recent OFDM and OFDMA-based IEEE 802.11-series standards have enough static reflection-dominated FSF resistance for indoor environments. In both environments, the selected protocols allow FSF impacts to be obviated by resulting extreme channel equalization and scheduling to such a level that only small allowances are required in link budgets (of the order of 3 dBr), compared to single-channel narrow-band communications technologies in which FSF may generate in excess of 40 dBr total link fade, as discussed in reference [E1].

## 2.2 MISSION DESIGN DRIVERS

This CCSDS Recommended Standard for space high data rate proximity wireless networking provides a technology basis for scalable reusable architecture. International space agencies have an urgent need to identify a modern communication architecture to provide proximity communications in the vicinity (**up to 10 km**) of a space vehicle or planetary habitat. The chosen architecture needs to be able to support a broad class of future exploration missions,

both robotic and crewed. International space agencies, including NASA, CSA, Roscosmos, and ESA, have identified a similar need. The chosen architecture needs to be able to support many different applications, often simultaneously, including all listed in table 2-1.

**Table 2-1: Space Exploration Mission Activities**

EVA	Telemetry data transport
Telerobotic activities	Environmental/structural monitoring
Rendezvous and docking – Command, monitoring, range safety, payload data	Payload communications
Crew audio and video streaming	Wireless medical instrumentation

The enabling characteristics of the architecture, which can be mapped to the operational requirements of many different missions that encompass the applications listed above, as well as others, include:

- support for data rates up to 100+ Mb/s for individual nodes and up to 1+ Gb/s for total network throughput;
- capability of supporting operations in a radius up to 10 km around primary vehicle or habitat without other fixed infrastructure;
- low size, weight, and power;
- extensive mobility;
- scalability up to 100 s of nodes and capable of rapid, dynamic reconfiguration;
- support for client device multi-hop to provide continuous connectivity and range extension;
- multiple levels of Quality of Service (QoS) support to satisfy reliability requirements.

In addition, the chosen architecture should have been implemented and demonstrated in a related demanding application area such as public safety, tactical military communications, or the International Space Station (ISS). The architecture and supporting systems should be based upon, or related to, a well understood existing standard with widespread application, a well-established record of utilization, thriving user and developer communities, and a defined and publicized roadmap to guide evolution and adoption.

There is widespread agreement that a solution should include elements based on the IEEE 802.11 (Wi-Fi) family of standards. This is the result of the extensive utilization of this family of standards throughout all segments of the terrestrial WLAN application area. In addition, this family of standards continues to be improved and upgraded frequently, and backwards compatibility is always maintained in the revisions. It is widely anticipated that 802.11 WLANs will ultimately be incorporated into future heterogeneous cellular networks based on LTE or 5G standards.

However, the 802.11 family of standards does not include all of the required enabling characteristics listed above. As a result, there are several proprietary extensions of the 802.11 standard that extend the capabilities of commercially available 802.11 chips to include more robust meshing behavior. Pragmatically, the 802.11 family is not designed to operate at the required 10-km range and cannot meet this requirement in a multi-node/multi-point network. An additional constraint of current 802.11 wireless standards is the lack of explicit support for both QoS and mobility of space exploration mission components. For practical purposes, the multihop mesh relay capability is almost never implemented because of the poor performance of that aspect of the standard with respect to mobility, scalability, and dynamic re-configurability.

3GPP LTE provides advanced wireless network services as compared to Wi-Fi at the cost of complexity. LTE provides Infrastructure-level interoperability, longer-range operations, high-speed interoperable mobile communications with fine-grained QoS capabilities along with support for low-latency mission critical networking (see table 2-2).

Operating frequency selections made during mission design should be compliant with the ITU Radio Regulations such as references [39], [38], and [37] and with SFCG recommendations (references [33] and [42]).

## **2.3 WIRELESS COMMUNICATION RELATIVE MOTION, RANGE, AND DATA RATES**

Wireless communications coverage ranges and data rates, at the time of document publication, are generically classified as shown specified in table 1-1.

The 3GPP specifications are designed for a maximum relative motion speed (between basestation and UE network endpoints) of 500 km/hr in support of high-speed mobility (see reference [35]). It should be noted that typical space vehicle (e.g., ISS) docking speeds are 0.0325 m/sec, which is 0.117 km/hr. Specifications for Wi-Fi maximum relative motion speed are non-existent as Wi-Fi was not designed as a mobile wireless technology. A reasonable engineering estimate for Wi-Fi maximum relative motion speed would be 5 km/hr (walking speed). It should also be noted that there is no design specification for maximum relative acceleration in the 3GPP specifications for terrestrial surface operations (e.g., not 3GPP Non-Terrestrial Networking, NTN). Maximum relative acceleration is a specification of space links which are not between two fixed points (such as orbit-to-orbit scenarios).

## **2.4 STANDARDS EVOLUTION FOR FUTURE ADVANCED CAPABILITY**

### **2.4.1 INTRODUCTION**

This document references and recommends two major standards paths: the IEEE 802.11 standards and the 3GPP (LTE and beyond) standards.

IEEE 802.11 (Wi-Fi) standards follow a set of standards sequences, sometimes splitting into multiple paths, with corresponding occasional roll-ups of standards and technologies into one

single standard. The recommendations of requiring a given standard include considering all of those standards subsequent to that standard, in the same path, for potential evolution. Current Wi-Fi path sequences are as follows:

- a) IEEE 802.11n/802.11ax;
- b) IEEE 802.11ac/802.11ax/802.11be Extremely High Throughput (EHT);
- c) IEEE 802.11ad/802.11ay; and
- d) IEEE 802.11ah.

Distinguishing performance characteristics for the IEEE Wi-Fi wireless standards are concisely summarized below (see reference [E20] for IEEE 802.11 standardization timelines):

- IEEE 802.11n (2009 standard): 2.4 GHz and 5.8 GHz short-range contention-based PHY/MAC with primarily best-effort performance, with support of up to 600 Mb/s in extreme multi-antenna configurations;
- IEEE 802.11ac (2013 standard): 5.8 GHz short-range contention-based PHY/MAC with primarily best-effort performance, with support of up to 2.34 Gb/s in present (Wave2), with potential for up to 6.77 Gb/s in extreme multi-antenna configurations;
- IEEE 802.11ax (2020 standard—see reference [E20], 2019 certification program, 2021 planned certification program for extended band): Short-range time, space, and frequency-scheduled non-contention MAC for high efficiency and reliability. Initial operation at 2.4 GHz and 5.8 GHz but with extension to channels in 6 to 7 GHz, capable of 9.6 Gb/s. IEEE 802.11ax, marketed as Wi-Fi 6™ by the Wi-Fi Alliance, is the current generation Wi-Fi specification standard, and the successor to Wi-Fi 5™. The 802.11ax standard is designed to operate between 2 and 7 GHz as bands become available for 802.11 use. All Wi-Fi 6 devices work over the previously allocated 2.4 and 5 GHz bands. The Wi-Fi 6E™ designation is for products that also support the 6-7 GHz;
- IEEE 802.11be EHT (TBD availability): recently (2019) approved study group for a new standard for an extremely high-speed data rate improvement on IEEE 802.ax, full standardization targeted for 2024 (see reference [E20]), with large bandwidths and hence high operating frequencies. This standard would have even higher reliability than IEEE 802.11ax through the use of simultaneous coverage from multiple base stations;
- IEEE 802.11ah (2016 standard—see reference [E20], planned 2021 certification program): 900 MHz medium-range contention-based PHY/MAC, based on pre-IEEE 802.11n standards with improvements for reduced power and meshing. Maximum performance of 347 Mb/s in extreme configurations, at several times the range of IEEE 802.11n and IEEE 802.11ac;
- IEEE 802.11ad (2012 standard—see reference [E20]): 60 GHz very short-range and medium-range beamformed contention-based PHY/MAC, capable of functioning at

6.8 Gb/s in original standard, but only 4.6 Gb/s in present standards and implementations (thus slower than potential future IEEE 802.11ac products), but in very small form factors because of the small wavelengths used;

- IEEE 802.11ay (planned late 2020 standard—see reference [E20]): Improvement of IEEE 802.11ad, operating with same contention-based approach and on same frequencies, with channel bonding and improved spatial spectral re-use, capable of achieving 176 Gb/s total capacity, with of the order of 40 Gb/s per device and multiple simultaneous communicating devices, at short-to-medium ranges in free-space conditions (up to 500 m).

The 3GPP standards include the modern LTE standard, starting at 3GPP Release 8, that is the basis of modern mobile (cellular smartphone) communications. LTE has undergone many stages of evolution, and thus 3GPP Release 12 and above are suggested in these recommendations. LTE supports both Time Division Duplexing (TDD) and Frequency Division Duplexing as forms of user multiplexing (see annex G). However, from Release 15 onwards, 3GPP standards become 5G standards, which are designed for extremely high data rates (10-100 Gb/s), and highly mission-critical reliability, at extremely low latencies (sub 1-ms RTT). These standards support longer ranges (up to approximately 70 km in usable implementations) and operate over a wide range of frequencies. The 3GPP specifications are designed for a maximum relative motion speed (between basestation and UE network endpoints) of 500 km/hr in support of high-speed mobility (see reference [35]). (It should be noted that typical space vehicle (e.g., ISS) docking speeds are 0.0325 m/sec, which is 0.117 km/hr). Because of their relative maturity and history of field deployment in public safety applications, 3GPP LTE releases comprise the scope of recommendations in this document. However, evolution of the Recommended Standard toward 3GPP 5G releases is anticipated as those releases mature toward small deployments in remote, resource-deprived scenarios.

As part of this evolution toward 5G, in addition to a 5G New Radio (NR) RF interface, the 4G LTE Evolved Packet Core (EPC) is replaced by a completely new architecture, the 5G Core (5GC). For an LTE network to be able to connect to a 5GC for either network evolution or interoperability, certain interfaces need to exist in the EPC and should be implemented in any spaceflight systems expected to evolve to support inter-agency interoperability and/or network evolution.

Wi-Fi and LTE/5G networks both support broadcast and unicast communications; however, multicast communication support is a research and development activity for both IEEE 802.11 and for 3GPP LTE/5G. Well-known issues with multicast have prevented the deployment of multicast group communications in 802.11 Wi-Fi and other local-area wireless environments, as described in reference [23]. In the 3GPP, Multimedia Broadcast Multicast Services (MBMS) is a point-to-multipoint interface specification for existing and upcoming 3GPP cellular networks. It is designed to provide efficient delivery of broadcast and multicast services, both within a cell as well as within the core network (reference [24]). For broadcast transmission across multiple cells, it defines transmission via single-frequency network configurations. The specification is referred to as evolved Multimedia Broadcast Multicast Services (eMBMS) when transmissions are delivered through an LTE network (reference [25]). eMBMS is also known as LTE Broadcast (reference [26]).

Both of the recommended two major standards organizations, the IEEE and the 3GPP, have established roadmaps and activities to incorporate satellite components into the wireless networking communications architecture. The IEEE Future Networks group has published an International Network Generations Roadmap (reference [E17]) in which several reference use cases are considered for satellite-enhanced 5G, including eMBB (Enhanced Mobile Broadband), massive Machine-Type communications (mMTC), and Ultra-Reliable Low Latency Communications (URLLC). One of the main emphases for satellites in the 5G architecture includes backhaul communications; however, a more challenging scenario considers the role of satellites in the RAN. In the 3GPP, two 5G-satellite-related current work items are the technical specification of group services and system aspects (references [19] and [28]) and the technical study and specification of 5G NR RAN services for Non-Terrestrial Networks (NTN) (reference [20]).

#### **2.4.2 EVALUATION METRICS**

Figure 2-1 indicates the period from initial development to completion of the major IEEE 802.11 and 3GPP (LTE/5G) standards. It can be seen that the IEEE 802.11n, 802.11ac, 802.11ad, 802.11ax, and 802.11ah are quite mature standards, as are 3GPP LTE Releases 8 through 14. Fully compliant hardware is just becoming available for 3GPP Release 15/16 (5G) and for 802.11ax as of late-2019, and it will be one to two years until hardware for IEEE 802.11ah, 802.11ay, and any IEEE 802.11be EHT-derived standard, is available. Figures 2-2, 2-3, and 2-4 provide summaries of performance capability, range capability, power requirements, and mission-critical capability.

**Standards development & h/w availability timeline: 05-Jul-2020**

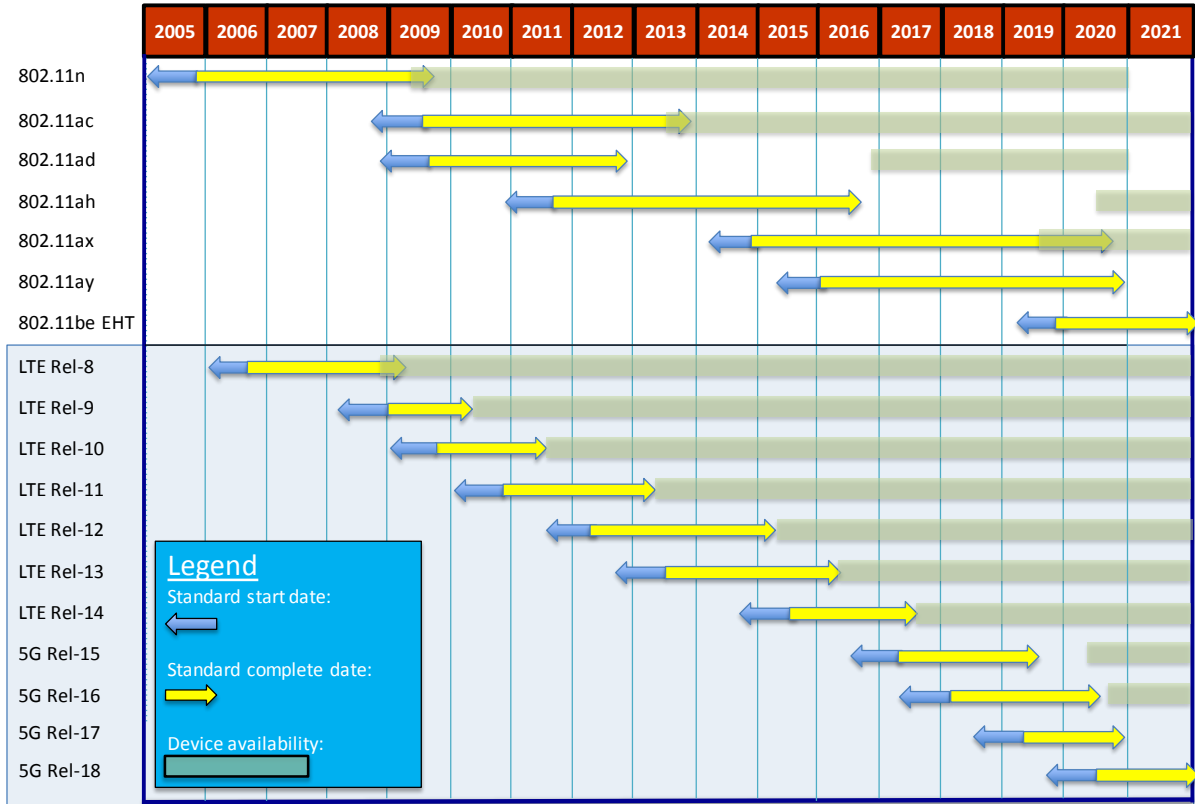

**Figure 2-1: Standards Development and Device Availability Timeline**

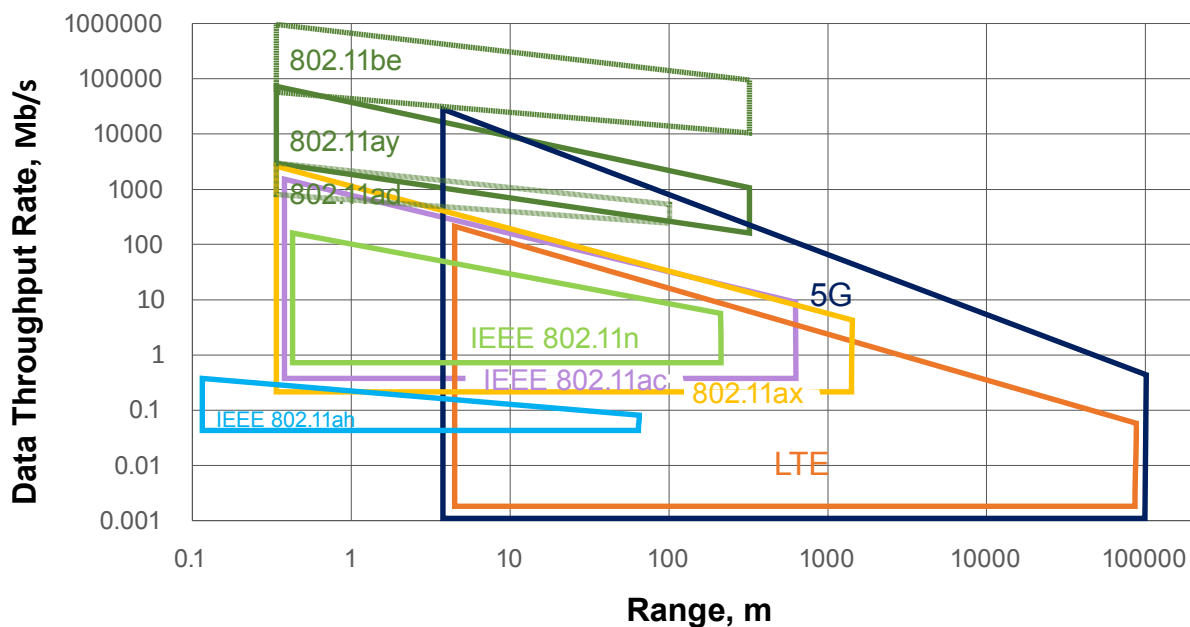

**Figure 2-2: Standards-Based Proximity Communications—Device Data Rate vs. Range**

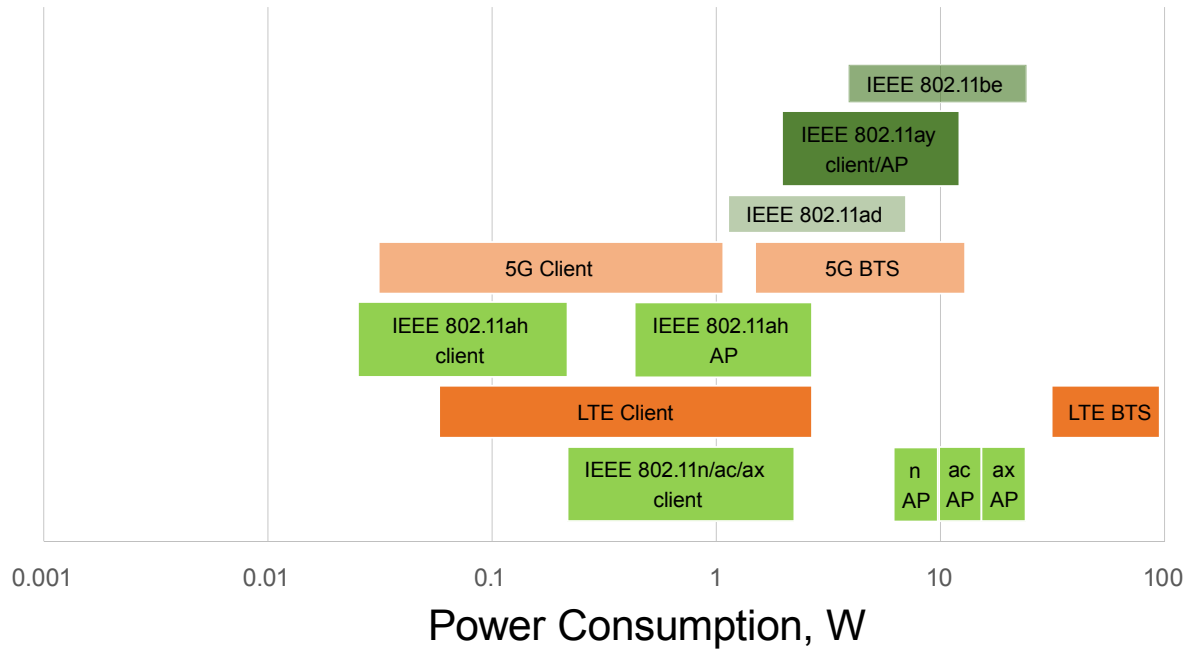

Figure 2-3: Standards-Based Proximity Communications—Power Consumption

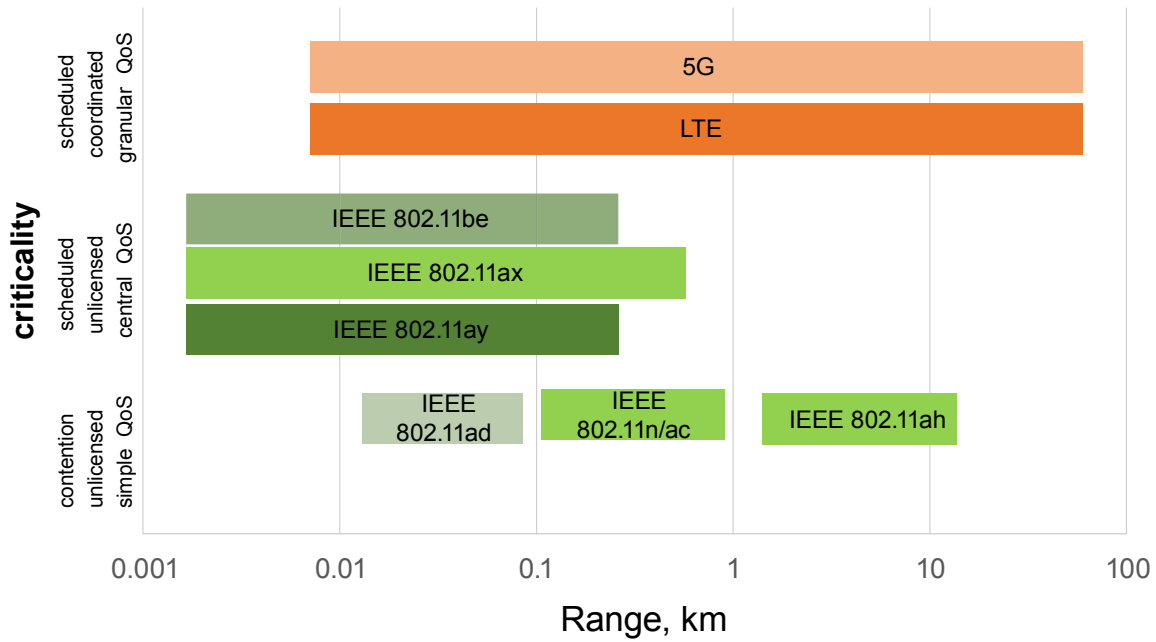

Figure 2-4: Standards-Based Proximity Communications—Criticality vs. Range

### **2.4.3 SPECTRUM AND USE-CASES FOR SPACE-BASED WIRELESS NETWORKS**

The two communication standards families, 3GPP and Wi-Fi, specified in this Recommended Standard, have explicit spectrum requirements for operation. Both sets of standards are designed for active and dynamic sharing of spectrum in various ways and various levels of operational criticality may be obtained without dedicated spectrum for each link in a system. The IEEE 802.11 technologies are designed for many networks to be implemented in the same location on the same channels, with an evolving ability to manage interference and scheduling in the shared band for independent networks. The 3GPP standards around LTE and 5G are designed for day-to-day operation of multi-cellular networks with each adjacent base station operating on the same channel, with the ability to manage intra-channel and inter-channel scheduling and handover as required to maintain extremely high QoS, when corresponding network protocols are established between base stations.

However, spectrum allocations used in the 802.11 and 3GPP standards are allocated by the ITU for terrestrial use on Earth and not in space, and may not be directly transferrable for use in the lunar region nor at Mars. For any type of space mission communications (mission critical or not), the bands planned to be used (non-space and space bands) must be requested from the ITU and used for wireless proximity communications in space on a non-interference basis. Mission planners should also consult with SFCG Recommendations (reference [33]) or liaise with their Agency's SFCG representative as to the appropriate frequency bands to use for wireless proximity links in space, especially in the lunar and Mars regions. If the intended lunar surface wireless frequency band is not in reference [33], their Agency's SFCG representative will have to make a waiver request to SFCG. There are special Radio Astronomy constraints for the Shielded Zone of the Moon, according to the applicable Radio Regulations (references [38] and [39]), and coordination is required.

The SZM, as defined by ITU (reference [38]), includes Mars and extends into the solar system. Reference [38] states: 'the 300 MHz to 2 GHz range should be reserved for radio astronomy observations'. Reference [39] also indicates that new bands are possible in the SZM between 2 and 3 GHz, and above 3 GHz, to be decided in agreement with the Radio Astronomy community. Because of the specific Radio Regulation applicable in the SZM, a transmission in that zone needs to be coordinated previously with Radio Astronomy, including when declared on a non-interference basis. There are Radio Astronomy representatives at the international level (IAU, ITU-WP7D, and IUCAF) and at the regional level (CRAF, CORF, and RAFCAP). SFCG guard bands need to be considered, such as for instance the 3.5 MHz guard band defined between the 2400–2480 MHz wireless lunar band and the 2483.5–2500 MHz orbit to surface PNT band.

### **2.4.4 ADDITIONAL CONSIDERATIONS**

Space agencies should strongly consider that operational, scientific, and payload data rate requirements are continuously increasing. This can be seen by the range of network data rates that are possible by the wireless standards considered in these recommendations, with

technologies ranging from several hundred Mb/s to 100+ Gb/s per base station and/or total local radio network for multi-cellular, multi-carrier proximity wireless communications networks (it should be noted both 3GPP/5G and IEEE Wi-Fi reuse spectrum between adjacent nodes for network capacity far higher than node spectrum bandwidth). Thus, for full expansion capability of future space vehicles and satellites, upgradable network technologies such as optical fiber, which supports data rates up to 1 Tb/s eventual capacity, should be considered.

For the multiple networks (wired and wireless, internal and external, dynamic network merging) envisioned to support the requirements for space agency exploration communications, network orchestration is recommended to coordinate the hardware and software components for a software application (e.g., high definition video streaming) or to support Gateway payload and crew services. Network Orchestration is the process of automatically programming the behavior of the network, so that the network smoothly coordinates with the hardware and the software elements to further support applications and services at an end-to-end level. Orchestration provides automation capabilities to dynamically manage network services, data flows, and management requests to eliminate manual human intervention required to deliver an application or service.

#### **2.4.5 MISSION CRITICAL KEY PERFORMANCE INDICATORS**

Table 2-2 provides a summary of 802.11 and LTE wireless technologies domain applicability based upon mission-critical performance indicators of Quality of Service (QoS), achievable data throughput, and support for high-speed mobility. It is the requirement to provide guaranteed QoS at required data rates, and, the ability to support asset mobility that mandates the consideration and utilization of the 3GPP technologies of LTE and the follow-on 5<sup>th</sup> Generation of mobile cellular system technologies (5G and eventually 6G).

**Table 2-2: Wireless Technologies Key Performance Indicators Assessment**

Wireless Standard	Internal Comms	External Comms	Low Network Mobility	High Network Mobility	Non-Critical	Mission Critical	Midrate Data	High-Rate Data	Very High Rate	Range			
										S	M	L	VL
802.11ah	x	x	x		x		x (note 2)				x	x	x
802.11n (note 4)	x	x	x		x		x			x	x		
802.11ac	x	x	x		x			x		x	x		
802.11ax	x	x	x		x	x			x	x	x		
802.11ad	x	x	x		x				x	x			
802.11ay	x	x	x		x				x (note 1)	x			
802.11be	x	x	x		x	x			x (note 1)	x	x		
LTE	x	x		x	x	x		x			x	x	x
5G	x	x		x	x	x (note 3)			x		x	x	x

**NOTES**

1 Extremely high throughput (EHT).

2 802.11ah @ 900 MHz HaLow is low to midrate throughput.

3 5G is more mission-critical than 802.11ax or LTE and is comparable to wireline-grade latency and resilience.

4 This Recommended Standard specifies recommendations for IEEE 802.11n, 802.11ac, 802.11ax, and 3GPP LTE, in coordination with SFCG and applicable Radio Astronomy representatives. Mission designers should only consider IEEE 802.11n products for legacy system maintenance and operational support.

**NOTES**

- 1 The IEEE evolution path is (see annex subsection C2): 802.11n 2.4 GHz/5 GHz (Wi-Fi 4), 802.11ac 5 GHz (Wi-Fi 5), 802.11ax 2.4 GHz, 5 GHz (Wi-Fi 6) 6 GHz (Wi-Fi 6E), 802.11be 2.4, 5, 6 GHz (expected to be Wi-Fi 7); IEEE 802.11n (Wi-Fi 4) products are recommended only for legacy system maintenance as these products are deprecated.
- 2 The 3GPP evolution path is 4G LTE, 5G, 6G (see annex subsection C3).
- 3 Follow-on successor Blue Books relating to Proximity Wireless Network Communications may specify recommendations for IEEE 802.11ah, 802.11ad/802.11ay, 802.11be, and 3GPP 5G (see annex H), to be used with prior coordination with SFCG and applicable Radio Astronomy representatives.

**2.4.6 LIMITATIONS OF PRESENT RECOMMENDATIONS AND FUTURE DIRECTIONS**

The present 3GPP and IEEE Recommendations are based on hardware and software available for international interoperability testing by CCSDS Members. However, there are many internationally interoperable 3GPP and IEEE technologies in existence and used on a daily basis worldwide. Many of these technologies are based on large commercial infrastructures that are rapidly becoming available in SWaP factors that will make them appropriate for spaceflight in the near future. It is expected that near-term evolution of these Recommendations will incorporate these technologies, many of which are described in detail in reference [E1], earlier in this section, and in annex C, Wireless Proximity Network Communications Technologies, and corresponding annexes of this document.

For the 3GPP Recommendation path, there are the following limitations and expected evolution:

- The present network sharing Recommendations in this document use either two networks running on the same RAN, via Multi-Operator Core Networking (MOCN), or an interoperability connection outside the network core, using Access Point Name (APN) routing. These are Mobile Virtual Network Operator (MVNO) approaches usually used inside a single nation between network operators with common heritage and tight partnerships and are optimized for such scenarios. However, internationally, roaming is the primary technology used for international operator interoperability across differing RAN technology networks with independent management, usually implemented in LTE via Gateway Core Networking (GWCN) using the LTE S8 and S6a interfaces, with further evolution planned in 5G (annex subsection C3, 3GPP Evolution), and there will be a need for future near-term Recommendations in this area to support flexible international interoperability between space agency and commercial provider networks.
- The present network interface Recommendations in this document only specify the general combined control- and user-plane version of each interface and corresponding network function. However, as a step toward 5G, modern LTE commercial production networks are now implementing Control User Plane Separation (CUPS), in which most interfaces and functions are replaced by separate control- and user-plane variants, as described in annex subsection C3.5, Core Evolution to Control User Plane Separation. For both improved QoS and 5G integration, CUPS is required in future near-term Recommendations.

For the IEEE 802.11 Recommendation path, there are the following limitations and expected evolution:

As this document is being published, several IEEE standards and Wi-Fi Alliance certification programs are nearing completion. This document cannot recommend those standards because products cannot yet be evaluated. However these next-generation standards are likely to be applicable candidates offering performance increases and maintaining interoperability with past generations. Wireless interfaces anticipated in the year 2021 include Wi-Fi CERTIFIED 6E™ products implementing features in IEEE 802.11ax, Wi-Fi CERTIFIED HaLow™ products implementing features in IEEE 802.11ah, and Wi-Fi CERTIFIED WiGig™ products implementing features in IEEE 802.11ay.

## 2.5 IEEE 802.11 SERIES TO 3GPP SERIES STANDARDS COMPARISON

### 2.5.1 GENERAL

General key performance indicators of selected standards are shown in table 2-2, and should be considered significant drivers for mission technology and standards selection. However, in operational missions, the communications architectures both drive the communications standards to be used and are driven by those standards. It is therefore important to classify the architecture and capability differences between the IEEE 802.11 series and 3GPP series of standards to allow for better mapping of standards to mission use. This classification is shown in table 2-3.

**Table 2-3: Capability-Driven Standards Selection**

	IEEE 802.11	3GPP	Implications
Configuration Simplicity	Yes	No	IEEE 802.11 series wireless networks are appropriate to missions with simple requirements and a minimum of interoperability requirements.
Infrastructure-Level Interoperability	No	Yes	A multiple agency or partner infrastructure can be built with 3GPP series technology and preserve full capability.
Long-Range Operations	No (apart from IEEE 802.11ah)	Yes	Single-node 3GPP-series networks can provide long-range networks around a spacecraft or for surface operations.
Regional Coverage	No (apart from IEEE 802.11ah)	Yes	3GPP networks are designed for long-range cellular coverage over large surface areas.
Mobility	Yes (if hardware supports it)	Yes	Both IEEE 802.11 series and 3GPP series wireless networks support a level of mobility across multi-node infrastructures.
Interoperable Mobility	No	Yes	A network supporting full mobility across many wireless infrastructure nodes can be built with 3GPP series technology and implemented across multiple agencies.
Mission-Critical Networking	No (apart from IEEE 802.11ax and later)	Yes	3GPP series technology networks provide increasing levels of mission-critical networking. Only IEEE 802.11ax (in IEEE 802.11-2020) later can provide a basic level of mission-critical networking.
Direct Mode	Yes, but at low range (except for IEEE 802.11ah which can function at km-class ranges)	No (in standard from Rel-13, awaiting full implementation, but with km-class ranges in standard and proprietary solutions, see 2020 C-V2X activities in references [E18] and [E19])	IEEE 802.11 series wireless networks are immediately appropriate to missions requiring short-range emergency direct mode communications. Further hardware implementation is required for standard implementations of this functionality in 3GPP series networks, although long-range proprietary solutions are available.

Some classes of mission will reduce risk by implementing dissimilar redundancy, overlapping two wireless networking technologies with dissimilar product lines and dissimilar radio channels. The following subsections provide an explanation of table 2-3. Other sections in this document provide a more detailed review of corresponding standards.

### **2.5.2 CONFIGURATION SIMPLICITY**

The IEEE 802.11 series standards-based products allow for extremely simple configuration in terms of system size and setup complexity. The 3GPP series standards-based products generally require significantly more expertise to configure and are physically larger, requiring more system engineering. The simplicity of the IEEE 802.11 series comes with significantly reduced capability and reduced interoperability, but missions that do not require this capability and/or interoperability may function with IEEE 802.11 series standards.

### **2.5.3 INFRASTRUCTURE-LEVEL INTEROPERABILITY**

There is a significant difference between the IEEE 802.11 series and 3GPP series of standards when it comes to interoperability, which may impact mission design and technology selection, especially if multiple space agencies and/or other partners are involved. The difference is that, although both IEEE 802.11 and 3GPP standards organizations support multi-vendor network client to network infrastructure interoperability, only the 3GPP series supports interoperability between infrastructure components across multiple vendors. Therefore, for full capability in an IEEE 802.11 wireless network infrastructure, the infrastructure nodes (APs) and other supporting infrastructure (components for wireless network control) generally need to be supplied from the same vendor. The result of this restriction is that IEEE 802.11 networks cannot generally be evolved or supplied piecemeal, adding complexity to network improvement and to construction of a multi-agency/partner wireless network infrastructure. If technology evolution and inter-agency interoperability is required at the wireless network infrastructure level, 3GPP series network infrastructure is required.

### **2.5.4 LONG-RANGE OPERATIONS**

It is important to consider communication range (maximum single-node to single-node separation) independently to coverage (actual area or volume of covered communications region by a complete communications infrastructure). As discussed in 2.4, IEEE 802.11 and 3GPP standards-based technologies have roadmaps that support similar maximum data rates. Therefore, as can be seen in figure 2-4, the different series of standards are optimized for different range use-cases.

The 3GPP standards sequence is better-suited than the IEEE standards for high-rate long-range communications above 1-km range, and potentially above 100-km range, but with IEEE 802.11ah allowing for some extended range operations, up to a few km, above the capability of other standards in the IEEE 802.11 family. Thus the 3GPP series is more

appropriate to vehicle-to-vehicle and surface communications. This is also apparent in the terrestrial use cases and requirements for the IEEE 802.11 series (wireless LAN) and 3GPP (wireless MAN) series.

However, if short-range communications are required, IEEE 802.11 standards may be more appropriate, given the generally larger infrastructure requirements for the 3GPP standards. Additionally, both series of standards only reach their maximum ranges in appropriate physical environments and situations. In particular, 100 km-class communications require either free-space communications or, for the surface environment, infrastructure on km-height elevations.

### **2.5.5 REGIONAL COVERAGE**

For communications on board or around a large spacecraft, or on the surface of an exploration destination, single nodes may not provide enough coverage. Indeed, in occluded environments such as on board a spacecraft, IEEE 802.11 may be limited to tens of meters. In flat, smooth surface environments 3GPP communications may be constrained to a few kilometers, but are capable of approaching 100 kilometers in range terrestrially when base-station antennas are mounted at higher elevation than immediate surroundings. Thus both series of standards may be restricted below maximum possible communication range. In these environments, or in any scenario in which coverage is not possible with a single infrastructure node, coverage is only possible if many infrastructure nodes can be combined to provide coverage over the entire desired communication volume. Earlier IEEE 802.11 standards, designed to provide room-scale communications, were not optimized for multiple-node infrastructure, but Enterprise-grade IEEE 802.11 (see Scalable Architecture for IEEE 802.11 Protocols in reference [E1]) is a modern mechanism for small coverage volumes. 3GPP standards have been driven by cellular communications requirements from their inception, and all 3GPP implementations are capable of a wide class of multiple-node communications, including cooperative inter-node multipoint, sophisticated dynamic interference management, carrier aggregation, and many more techniques designed for large multi-node planetary-scale networks to accommodate terrestrial 3GPP design drivers. Thus, combined with higher 3GPP ranges per infrastructure node, 3GPP-based wireless networks provide far greater coverage than IEEE 802.11-based wireless networks for a given number of infrastructure nodes, at far greater data rates, device densities and spectral efficiency. If communication volumes corresponding to ranges above 5 km or more are required, the 3GPP series standards are the only appropriate solution for high-speed multi-point communications. If surface coverage ranges of less than 100 m are required, IEEE 802.11 series standards will generally be a simpler choice for relatively static and less spectrally demanding design conditions. Coverage ranges between 100 m and 5 km will generally require more extensive analysis on a per-mission basis, but it is important to note that this range of coverage requirements can generally be supported by a single-node 3GPP series standard network, or potentially via IEEE 802.11ah, assuming attendant hardware availability.

### **2.5.6 MOBILITY AND INTEROPERABILITY**

If mobility across an entire communication region is required by a mission scenario, simple coverage will not suffice. In a multi-node, cellular-style network, the ability to roam (in 3GPP language) or handover (IEEE 802.11 language) is the function that supports dynamic mobility of clients between infrastructure nodes. Without the roam/handover functionality, network socket connectivity cannot be preserved across the process of a client moving from the coverage of one infrastructure node to another, and the network only supports static operation in its coverage region. With roam/handover functionality, the entire coverage region of the network functions as a single-node network would, providing highly stable robust networking for fully mobile clients.

For IEEE 802.11 networks, only Enterprise-grade networks provide for full handover functionality, using a subset or all of the IEEE 802.11r, 802.11v, and 802.11k standards. These standards are purely between client and infrastructure Access Point (AP) nodes, allowing the clients to appropriately signal to the AP nodes in a multi-node network to allow the discovery, de-association, and re-association processes to allow transition of a client from one AP to another without a break in network sockets and communication. However, for this functionality to be achieved, there needs to be communication between the APs. There is no present consistent standard between vendors to allow this inter-AP communication to be interoperable. Thus infrastructure needs to be provided by a single vendor to allow mission-critical robust mobility. This does not allow for an infrastructure provided by multiple space agencies in a network, although it does allow for client systems from multiple agencies to operate on the single-agency IEEE 802.11 roaming infrastructure.

For 3GPP networks, there is a wide range of standards intrinsic to the functionality of all modern cellular networks that provide for infrastructure nodes (eNBs and gNBs for LTE and 5G standards, respectively) to support clients' User Equipment (UE) roaming across an entire infrastructure with full vendor interoperability at both the infrastructure and client level. Thus, in a 3GPP network, multiple agencies can supply components of the infrastructure, and multiple agencies can supply clients on the network, while still having full interoperable mobility.

### **2.5.7 MISSION-CRITICAL NETWORKING**

Any network can be overloaded. Quality of Service features control what happens under these conditions. Mission-critical networks are robust networks that isolate users and compartmentalize the performance changes of individual client devices. This provides a more deterministic user experience that is based on the performance parameters of the individual user.

As wireless networks evolve, attract more applications, and carry more traffic, quality of service (QoS) has been a maturing capability that enables a shift toward mission-critical network operations. It is important to consider that mission-criticality in a network is dependent on the actual detailed mission requirements, and thus both selection of wireless standards series and the sub-standard in a series, will involve correspondingly detailed analysis.

In the IEEE 802.11 series, true mission-critical communications have not existed in the series until recently, because of the random contention-based approach used for multi-client operations. The previous IEEE 802.11 approach allocated QoS for uplink traffic to the clients. The first standard to move beyond this, IEEE 802.11ax (Wi-Fi 6), a component of the IEEE 802.11-2020 standard, adopts 3GPP-like modulation and resource scheduling that no longer uses contention-based access.

The 3GPP standards have always used scheduled resource allocation and can thus support mission-critical networking at some level. However, as the 3GPP series evolves from 4G to 5G, the standards are designed to move to far higher grades of critical operations by improvement of latency and other network performance guarantees.

Therefore IEEE 802.11 series standards before IEEE 802.11ax and IEEE 802.11-2020 should not be used for networks needing QoS. IEEE 802.11ax can provide some level of scheduled QoS, as can 3GPP series standards up to and including Release 14. For very high levels of QoS and high levels of mission-criticality, 3GPP Release 15 and later will be required.

### **2.5.8 DIRECT MODE**

In a highly mission-critical application of a wireless network, it is often considered to be important for there to be communication mode(s) to which user and client's systems can fail over if infrastructure-level communications are lost. In legacy UHF and VHF voice systems, this communication mode is either implemented via simplex (single-frequency) or turn-around (dual-frequency) modes available in the radios that do not need a radio repeater to enable direct user-to-user communications. Wireless networks generally cannot implement such a physically simple mode of operation and need to implement more sophisticated methods to provide communication when no primary wireless network infrastructure is available because of system failure or line-of-sight issues.

This discussion covers the case of purely infrastructure-free direct-mode wireless network communications, and not direct mode relay of traffic to and from devices out of infrastructure coverage by devices that are in coverage. The latter case requires deeper permission level architecture and mission operations analysis for appropriate solutions to be selected.

In recent implementations of the IEEE 802.11 series of standards, there has arisen a technique of providing effective direct-mode device-to-device communications by having one device transition to becoming an AP, using the same existing radio. This is a software solution and is generally known as Soft AP. Soft AP needs no extra standards, as it is purely an implementation of standard IEEE 802.11 series infrastructure standards. Once active, normal IEEE 802.11 clients can connect to the node supplying Soft AP services. Most modern smartphones, tablets, printers, and other IEEE 802.11 client devices support Soft AP and hence the ability to communicate without additional infrastructure. In addition to this, the Wi-Fi Alliance has defined a set of standard processes for wireless nodes to create and join a Soft AP-provided network, under the Wi-Fi Direct<sup>®</sup> standard (see reference [E14]).

A WFA certification for Soft AP is available, Wi-Fi Direct<sup>®</sup> Soft AP. Soft AP and Wi-Fi Direct have superseded earlier IEEE 802.11 series *ad-hoc* networks, in that the legacy approach provided a reduced form of IEEE 802.11 connectivity, with no security and a lack of many of modern IEEE 802.11 network capabilities. Wi-Fi Direct<sup>®</sup> provides security, and Soft AP can provide full modern AP functionality and security.

The 3GPP Direct Mode (see also annex subsection C3.6) functionality, standardized in 3GPP Release 13 via Proximity Services (ProSe), is not yet implemented in presently available COTS, although chipsets are available for the corresponding vehicular communications mode in 3GPP Release 14. Present Public Safety LTE devices requiring some form of Direct Mode functionality implement proprietary, and not standard, services, often using proprietary protocols over the LoRa (see reference [E15]) low-rate personal area networking wireless standard.

Therefore standard Direct Mode is only available in IEEE 802.11 in fully standardized and actually implemented protocols and hardware. However, Soft AP and Wi-Fi Direct Mode<sup>®</sup> solutions have the same range limitations of other IEEE 802.11 series systems and generally have reduced transmit (downlink) power compared to full AP hardware. Therefore, apart from IEEE 802.11ah, the direct-mode communication links may only be operational at ranges of tens of meters. This should be compared to ProSe and proprietary solutions, some now using LoRa, in which communications can be functional on ranges of approximately one kilometer.

## **2.6 SPECTRUM EVOLUTION PATH FOR FUTURE MISSIONS**

### **2.6.1 GENERAL**

The evolution of wireless technologies described in annex C results in an evolution of spectrum requirements and solutions. This evolution results in a need to consider the spectrum-allocation as a temporary solution based on a legacy approach to RF spectrum management, given that wireless communications are moving toward an approach based on dynamic allocation and sharing of RF spectrum. A potential roadmap for spectrum allocation evolution is described in 2.6.4.

### **2.6.2 SPECTRUM OVERLAP IN MODERN WIRELESS NETWORKS**

The two selected series of wireless networking standards are designed to operate even when two different networks are operated in overlapping spectrum. Additionally, the 3GPP series has evolved to cooperate with the IEEE 802.11 series to allow co-existence of the two technologies in the same spectrum.

IEEE 802.11 technologies initially used a combination of contention-based interference avoidance and signal scrambling to mitigate interference when two or more IEEE 802.11 networks are operating in the same or overlapping channels. Beginning with IEEE 802.11n, this co-existence has been further improved by the use of MIMO and the capability to

remove interference via beamforming and spatial coding. This solution is quite functional, as can be seen in the large number of IEEE 802.11 networks operating at any time. However, the contention-based approach results in a significant reduction in performance with an increasing number of co-existing wireless networks in a channel, with total all-network capacity dropping as the number of networks increases. The emergence of IEEE 802.11ax networks will allow for detailed control of spectrum, time, and spatial resources with an active monitoring of corresponding interference from these same resources on other wireless networks in the same operating channel. The result is that the total capacity of all IEEE 802.11ax networks operating on a given set of channels will be approximately constant as the number of co-existing networks increases. Indeed, when many spatial channels are available, the total capacity will increase with increasing number of networks on a channel. In the case of IEEE 802.11ay networks, massive MIMO (mMIMO) beamforming will result in almost no interference between networks due to extreme spatial channel isolation, allowing the total capacity to be proportional to the number of networks, for a given shared channel bandwidth.

For 3GPP networks, contention-based resource management is not used, and all 3GPP networks provide frequency, time, and spatial channel isolation of traffic. Additionally, 3GPP networks can support communication between infrastructure nodes (eNBs or gNBs) in the same network, allowing further interference reduction by efficient scheduling of all resources. Additionally, higher releases of 3GPP support increasing frequency and mMIMO, also allowing for spatial isolation of different networks operating in the same band. However, operation of a 3GPP network generally assumes a single 3GPP network per channel for network search and registration purposes. Thus 3GPP interference rejection and coexistence is primarily for coexistence of many eNBs or gNBs from the same network, in the same channel. However, this allows large 3GPP networks to be built using the same channel. Indeed, this is exactly how all modern cellular networks function, without different spectrum allocations from one cell tower to the next, including modern near Gb/s-class LTE-A Pro networks now deployed around the world.

EN-DC (E-UTRAN NR Dual Connectivity) allows 4G and 5G New Radio, ‘5G NR’ 3GPP networks to inter-operate. Indeed, for a single network operator, it is possible for an EN-DC network to split a given RF band into separate 4G and a 5G NR components, which can then be evolved to standalone 5G networks, in the same spectrum allocation, at a future date.

The creation of Licensed Assist Access (LAA) standards for 3GPP operation utilizing the same frequency bands employed by Wi-Fi, albeit requiring that a 3GPP network also operates in a licensed channel for control plane traffic, allows for shared use of Wi-Fi spectrum, with diminishing impact, between IEEE 802.11 series and 3GPP series technologies. This will also allow 3GPP networks to evolve into spectrum allocated for IEEE 802.11 networks. The 5G NR in 3GPP Release 16 will be able to operate completely in spectrum being used by IEEE 802.11 networks, via a standard called Standalone NR-U, in addition to the 5G equivalent of license-anchored LAA in LTE, called LAA NR-U.

NOTE – The LAA hardware may require non-licensed-device-type certification for terrestrial use.

### 2.6.3 DYNAMIC SPECTRUM ACCESS SYSTEMS

Citizens Broadband Radio Service (CBRS) is a 150 MHz wide broadcast band of the 3.5 GHz band (3550 MHz to 3700 MHz) in the United States. CBRS is based upon network-managed access to spectrum (as described in annex C). This process is known as the Spectrum Access System (SAS). 3GPP LTE and 5G operation in CBRS spectrum is accomplished using the SAS. In Europe, a corresponding standard has been released in 2017 for 2300-2400 MHz, called Licensed Shared Access (LSA), as ETSI TS 103.379 (reference [10]). This technology can be expected to evolve to other bands and, in the future, will allow for wireless networks to dynamically request spectrum as needed, without needing a central licensing authority or frequency coordination group to allocate spectrum.

### 2.6.4 SPECTRUM ROADMAP FOR FUTURE EXPLORATION WIRELESS NETWORK OPERATIONS

The evolving wireless network technology roadmaps for the IEEE 802.11 and 3GPP series of standards allow a potential roadmap for spectrum evolution for high-speed wireless networks in space exploration use cases.

#### **Spectrum Allocation: Non-Licensed Devices, Licensed Radio Services, and Space Operation**

Non-Licensed device radios are RF-transmitting devices that have obtained formal certification from the device manufacturer's national spectrum governing authority. The use of such devices terrestrially in their original certified configuration does not require an operator license. In addition, the spectrum bands used by a non-licensed device are typically shared with other radio services that require operator licenses; there are no unlicensed spectrum bands or non-licensed spectrum bands in the strict sense of the words. Importantly, it is the non-licensed device certification that allows the device to use spectrum associated with the device certificate without an operator license. The use of non-licensed devices in space is not covered by the certification; that is, there is no such thing as a non-licensed device when the device is used in space. The use of a certified non-licensed device in space requires either a license or explicit permission from the operator's national spectrum governing authority.

The term 'unlicensed' is used informally as a synonym as 'non-licensed'. Strictly speaking, unlicensed means the device has no license, and the expression can also describe an unauthorized device. An unlicensed device technical specification (data sheet) would not include any reference to any licensing requirements. This document references many other documents that use the terms 'unlicensed' and 'unlicensed spectrum'. When interpreting the term 'unlicensed' or 'unlicensed spectrum', readers are advised to think in terms of whether the equipment has obtained a non-licensed type certification, whether the equipment is used in the original certified configuration, and whether the equipment is used terrestrially or in space. As stated in the previous paragraph, using a terrestrially non-licensed device in space requires either an operator license or permission from the national spectrum governing authority.

### **Fixed Spectrum Allocation**

Presently, terrestrially based 802.11-based Wi-Fi networks employ non-licensed device hardware in the device's certified configuration, and users can access the designated Wi-Fi spectrum without an operator license. 3GPP 4G LTE networks require service providers to obtain operator licenses. Frequency bands utilized by 3GPP LTE and/or 5G are typically not allocated for space operations or for space research purposes. From a pragmatic perspective, the licensing for space operations/research may be problematic, and the space link will not have protected status.

### **IEEE 802.11 Wi-Fi and 3GPP LTE Spectrum Sharing**

Under the constraint that certified LAA non-licensed device hardware is available, 3GPP 3G LTE networks will be evolved to share the same spectrum with IEEE 802.11 networks. Current research evaluation has demonstrated that LTE-LAA allows for coexistence with incumbent access technologies such as Wi-Fi on a 'fair' and 'friendly' basis (see references [E21] and [E22]). This would be evolved further to LAA NR-U for 5G connectivity. Finally, standalone NR-U can be implemented to build 5G networks completely in IEEE 802.11 spectrum with simultaneous operation of IEEE 802.11 series networks. This would occur in addition to mid-band and mmWave 5G networks and mmWave IEEE 802.11ay networks.

### **Dynamic Spectrum Access**

Future spaceflight networks around large spacecraft and in multi-agency/partner surface exploration missions can evolve to use dynamic spectrum access technologies based on SAS and LSA, with spectrum only allocated and utilized when operationally required.

## **2.7 NETWORK MANAGEMENT**

Automated network management (orchestration) within 3GPP is a central feature of 5G evolution, but there are multiple standards efforts that are still in the process of being resolved while industry works toward a possible single uniform approach. Upper level non-automated network management is often based upon the Broadband Forum (BBF) standard TR-069 (reference [30]), but the actual approach can depend on vendor. Details are overviewed in Network Management in 3GPP Networks annex in reference [E1].

Protocol adaptation diagrams are given in figures 2-5, 2-6, 2-7, 2-8, and 2-9.

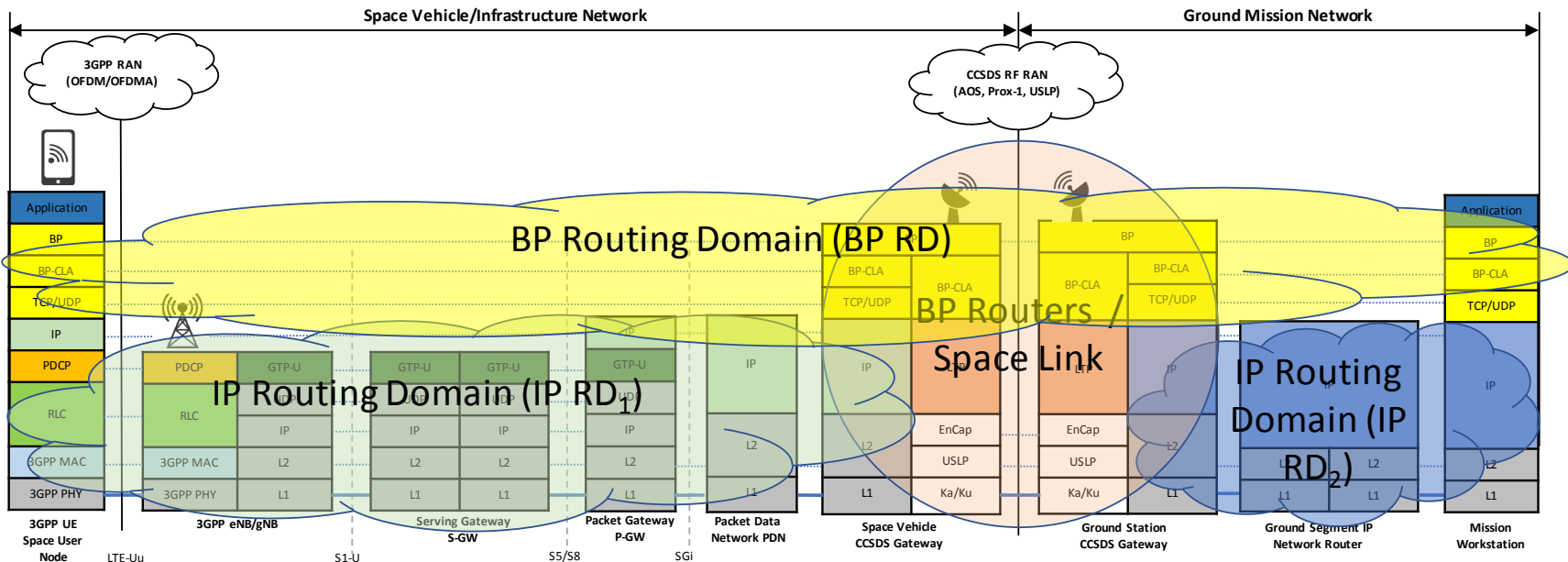
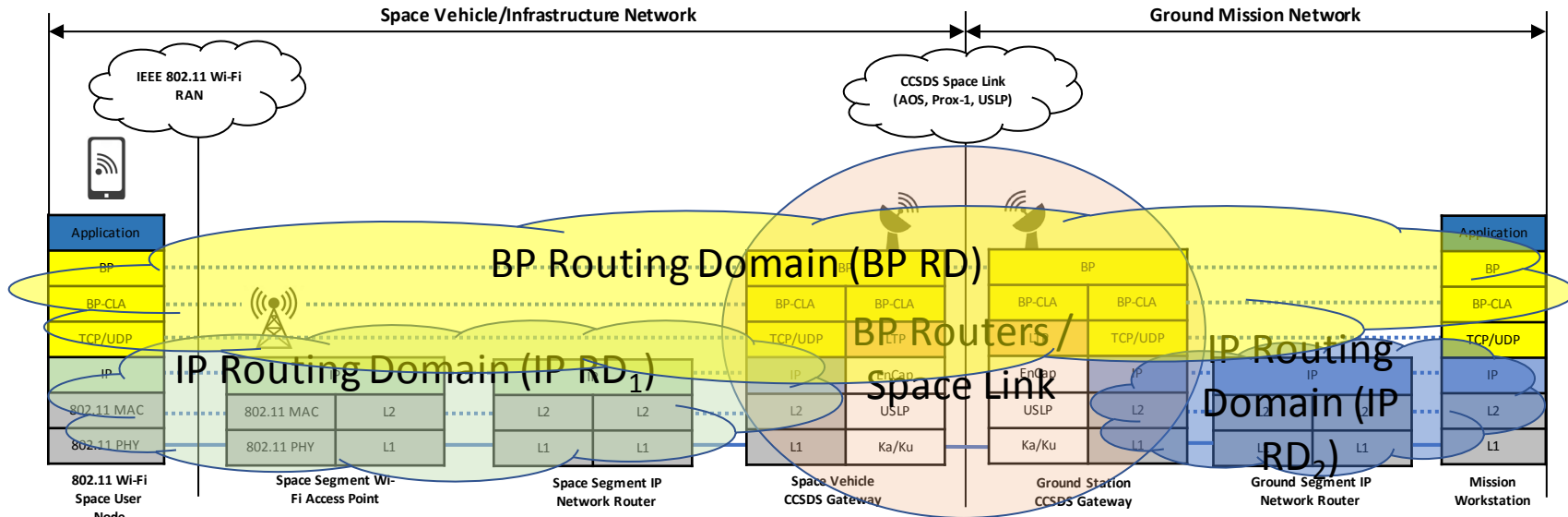

Figure 2-5: 3GPP User Plane CCSDS Adaptation Profile: DTN/BP End-to-End

NOTE – Figure 2-5 shows one BP Routing Domain, using two separate underlying IP Routing Domains (RDs) that serve as ‘logical link layer’. BP provides end-to-end Network Layer reliability. As shown, all devices use BP, and BP provides end-to-end network flows. The two IP RDs are separate, use separate IP addresses, and do not directly connect one to the other at the IP layer. They may use IP locally but transferring IP traffic from one RD to the other requires a protocol-matching, store-and-forward gateway to connect via BP/DTN (see figure 2-9). This deployment cannot provide end-to-end IP routing.



**Figure 2-6: IEEE 802.11 Wi-Fi CCSDS Adaptation Profile: DTN/BP End-to-End**

NOTE – Figure 2-6 shows one BP Routing Domain, using two separate underlying IP RDs as the ‘logical link layer’. BP provides end-to-end Network Layer reliability. As shown, all devices use BP, and BP provides end-to-end network flows. The two IP RDs are separate, use separate IP addresses, and do not directly connect one to the other. They may use IP locally but transferring IP traffic from one RD to the other requires a protocol-matching, store-and-forward gateway to connect via BP/DTN (see figure 2-9). This deployment cannot provide end-to-end IP routing.

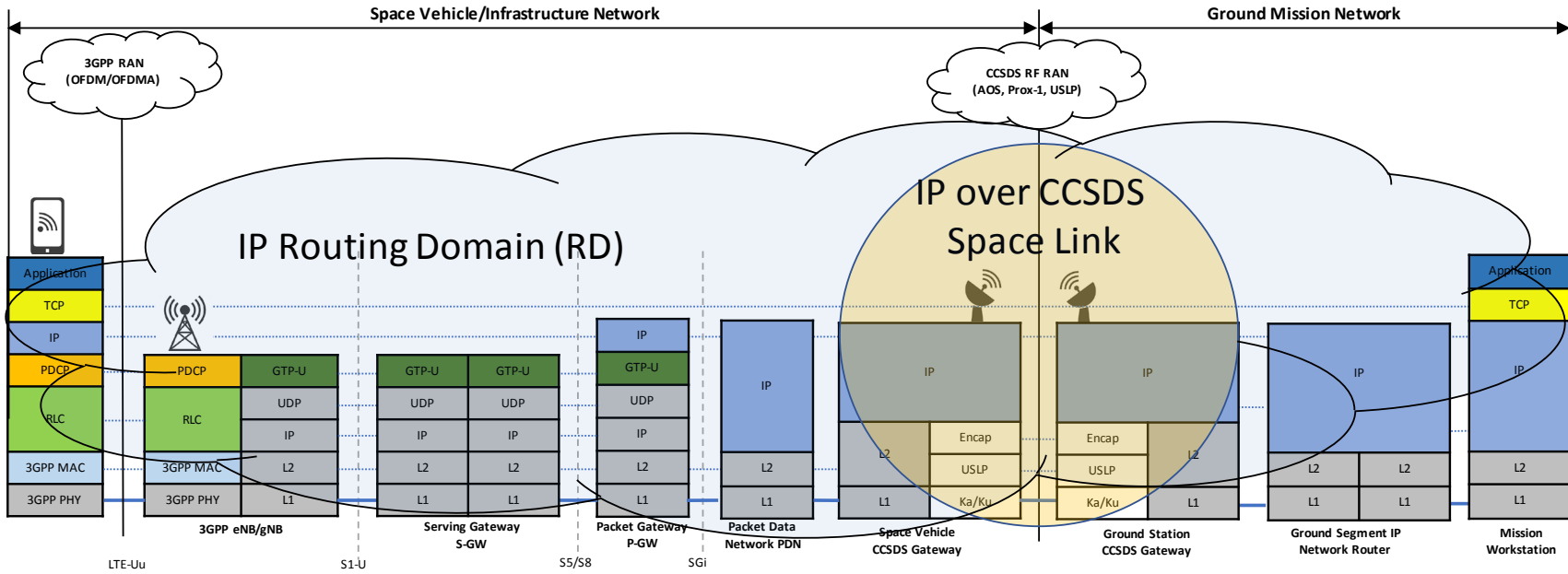

**Figure 2-7: 3GPP User Plane CCSDS Adaptation Profile: IP over CCSDS**

NOTE – Figure 2-7 shows a single IP RD running IP end to end over a CCSDS space link. This profile is suitable only for near-Earth, short RTLT deployments. In this deployment TCP/IP can provide end-to-end data flows and reliability.

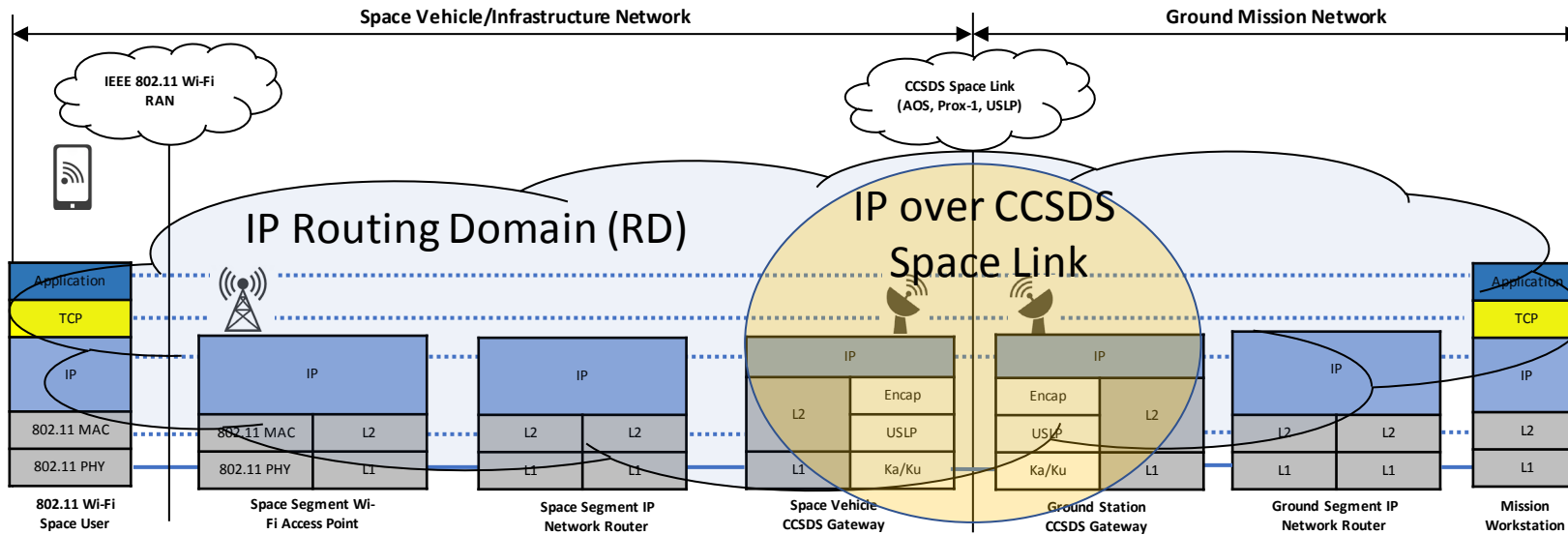

**Figure 2-8: IEEE 802.11 Wi-Fi CCSDS Adaptation Profile: IP-over-CCSDS (Near-Earth)**

NOTE – Figure 2-8 shows a single IP RD running IP end to end over a CCSDS space link. This profile is suitable only for near-Earth, short RTLT deployments. In this deployment TCP/IP can provide end-to-end data flows and reliability.

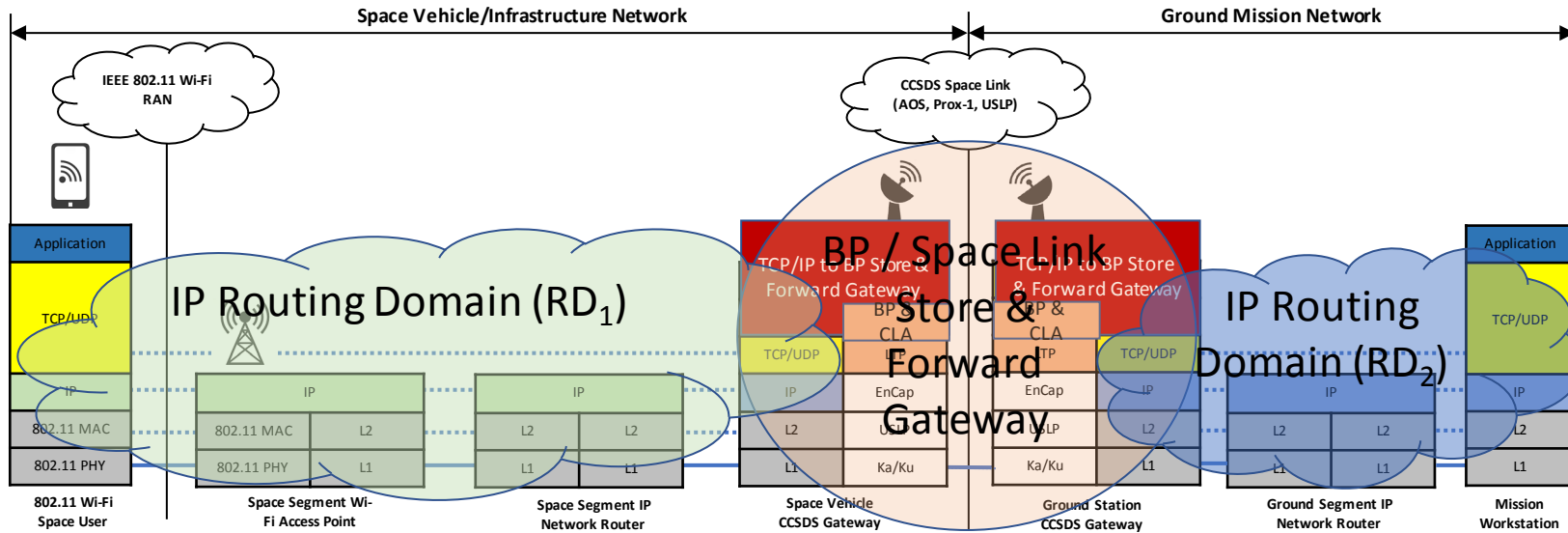

**Figure 2-9: IEEE 802.11 Wi-Fi CCSDS Adaptation Profile, BP for Long Haul Links, TCP/IP Requires BP Store-and-Forward Gateway**

NOTE – Figure 2-9 shows two separate IP RDs running IP within their bounds and using BP store-and-forward gateways over a CCSDS space link. The gateways do a limited amount of ‘protocol matching’ for the kinds of flows they are programmed to handle. It cannot support IP end-to-end semantics. This profile is suitable for deep space deployments. The blue RD and the green RD cannot use IP to route data from one to the other. The gateway using BP over LTP provides end-to-end, store-and-forward reliability, but does not support TCP semantics. It is suitable for deployments with long delays and/or interruptions on the space link. The gateway converting TCP to BP provides piecewise end-to-end delivery (CAVEAT BPv7, and custody transfer). Store-and-forward latency (or just latency) across the space link, and the necessary protocol conversions may break applications.

### **3 WIRELESS PROXIMITY NETWORKING COMMUNICATIONS RECOMMENDED STANDARDS**

#### **3.1 OVERVIEW**

This document references and recommends two major standards paths: the Wi-Fi Alliance certifications (heavily drawn from IEEE 802.11 standards) and the 3GPP (LTE and beyond) standards. Subsection 3.3 enumerates the specific recommended IEEE 802.11 Wi-Fi standards, and 3.4 enumerates the specific 3GPP standards. Both subsections include the recommended spectrum bands for space agency communication assets and equipment in support of exploration mission operations.

The standards-based recommendation herein are applicable to internal and external proximity wireless network communications, specifically in support of human space flight, or robotic, on-board and visiting-vehicle communications links, robotic and crewed EVA sorties, and surface-to-surface operations. These standards are only suitable for these close-range proximity applications which are subject to low-rate Doppler effects. These standards are not suitable for surface to orbital vehicle proximity communications or other links where the relative velocities or relative accelerations are substantially higher.

#### **3.2 FREQUENCY COORDINATION**

##### **3.2.1 GENERAL REQUIREMENTS**

This Recommended Standard does not provide any normative guidance in the frequency values of the permitted bands by the space systems using the wireless terrestrial standards covered in this book. Consequently, the following constraints on the frequency selection must be followed:

- a) The frequency band choices for lunar or Martian surface wireless transmissions could be impacted by ITU Recommendations (references [37] and [38]) and by the Radio Regulation (reference [39]) applicable in the SZM. Therefore, adopters must ensure compatibility with ITU Radio Regulations and comply with SFCG recommendations (references [33] and [42]).
- b) The use of any non-SFCG wireless frequency band shall be verified by liaising with the CCSDS Space Link Services (SLS) Radio Frequency and Modulation (RFM) Working Group (WG).
- c) Current SFCG lunar region recommended frequency allocation constraints are shown in tables 3-1, 3-2, and 3-3 (reference [33]). Before finalizing their frequency band choice, space agencies must ensure clearance for an SFCG waiver when the targeted frequency band is not recommended in the latest applicable version of reference [33] or of reference [42].
- d) A frequency-usage verification procedure must be followed as it is defined by the responsible bodies (which can include the SLS RFM WG).

**Table 3-1: Recommended Frequency Bands for Communications in the Lunar Region**

<b>Link</b>	<b>Frequency</b>	
Earth to Lunar Orbit	2025-2110 7190-7235 22.55-23.15 40.0-40.5	MHz (Note 1), (Note 2) MHz GHz (Note 2) GHz
Lunar Orbit to Earth	2200-2290 8450-8500 25.5-27.0 37-38	MHz (Note 2) MHz GHz GHz (Note 3)
Earth to Lunar Surface	2025-2110 7190-7235 22.55-23.15	MHz (Note 1), (Note 2) MHz GHz
Lunar Surface to Earth	2200-2290 8450-8500 25.5-27.0	MHz (Note 2) MHz GHz
Lunar Orbit to Lunar Surface	390-405 2025-2110 23.15-23.55	MHz (Note 4) MHz (Note 2) GHz
Lunar Surface to Lunar Orbit	435-450 2200-2290 27.0-27.5	MHz (Note 4) MHz (Note 2) GHz
Lunar Orbit to Lunar Orbit	2025-2110 2200-2290 23.15-23.55 27.0-27.5	MHz (Note 2) MHz (Note 2) GHz GHz
Lunar Surface Wireless Network	390-405 410-420 435-450 2.400-2.480 2.5035-2.620 5.15-5.835 25.25-25.5 27.225-27.5	MHz (Note 4) MHz MHz (Note 4) GHz GHz GHz (Note 6) GHz GHz
Lunar Relay to Lunar Relay Cross Link	13.75-14 14.5-15.35 23.15-23.55 27.0-27.5 37-38 40-40.5	GHz GHz GHz GHz GHz (Note 3) GHz
Amateur Radio Operation, Earth-to-Lunar Orbit	144-146 435-438 2.4-2.45 5.65-5.67	MHz MHz (Note 5) GHz (Note 5) GHz (Note 5)
Amateur Radio Operations, Lunar Orbit-to-Earth	144-146 435-438 10.45-10.5	MHz (Note 4) MHz (Note 4), (Note 5) GHz (Note 5)
<b>Notes to table 3-1</b>		
1	In making frequency assignments for uplinks in the 2025 – 2110 MHz band to missions operating in the lunar vicinity, careful frequency coordination should be performed and measures taken to minimize interference to spacecraft operating in low-Earth orbit and L1/L2.	
2	In these communication frequency bands, position and navigation information may be contained in integrated ranging signals. However broadcast signals intended for PNT in the lunar region should use the frequency bands specified in table 3-2.	

3	37-38 GHz band subject to SFCG Rec.14-2R5.
4	Frequencies to only be used outside the Shielded Zone of the Moon (SZM).
5	These frequencies are allocated on a secondary basis only, except 435-438 MHz is allocated primary in Region 1 and secondary in Regions 2 and 3.
6	5.25-5.57 GHz is allocated to SRS (active) on a primary basis; use of these frequencies for communications in the lunar region is on a non-interference and unprotected basis to SRS (active).

**Table 3-2: Recommended Frequency Bands for RNSS or RDSS Applications in the Lunar Vicinity**

Link	Frequency
Earth-based GNSS to Lunar Orbit and Lunar Surface	1164-1215 MHz
	1215-1300 MHz
	1559-1610 MHz
In-situ Lunar based RNSS/RDSS to Lunar Orbit and Lunar Surface	2483.5-2500 MHz
Note: RDSS: Radiodetermination-Satellite Service RNSS Radionavigation-Satellite Service	

**Table 3-3: Limitations Applicable to the Recommended Lunar Surface Communication Frequencies**

Link Type	Frequency Band	Limitations
4.0 Lunar Surface Communications	390-405 MHz	See Note 4 to table 3-1
	410-420 MHz	
	435-450 MHz	See Note 4 to table 3-1
	2.400 – 2.480 GHz	Sufficient OOB filtering to protect the 2483.5-2500 MHz LO-to-LS PNT band is necessary
	2.5035-2.620 GHz	Sufficient OOB filtering to protect the 2483.5-2500 MHz LO-to-LS PNT band is necessary
	5.15-5.835 GHz	
	25.25-25.5 GHz	Subject to SFCG Rec. 15-2R4
	27.225-27.5 GHz	Subject to SFCG Rec. 15-2R4

### **3.2.2 IEEE 802.11 CHANNEL PLAN**

This Recommended Standard intends that infrastructures operating in space should support commercially available terrestrial client devices. However, all infrastructure implementations shall use channel assignments, or a subset of channel assignments, compatible with the respective IEEE 802.11 standards and respect all SFCG spectrum allocations and other applicable frequency band constraints [33]. The channel assignments (carrier frequencies, main spectral lobes) selected by the adopter when a SFCG wireless band is used for Wi-Fi shall not be outside the said wireless band currently allocated by SFCG (references [33] and [42]).

### **3.2.3 3GPP LTE CHANNEL PLAN**

This Recommended Standard intends that infrastructures operating in space should support commercially available terrestrial 3GPP client/UE devices. However, all infrastructure implementations shall use channel assignments conforming, or a subset of channel assignments, compatible with the respective 3GPP LTE frequency band standards in 3GPP TS 36.101 (reference [7]) and respect all SFCG spectrum allocations and other applicable frequency band constraints. The channel assignments (carrier frequencies, main spectral lobes) selected by the adopter when a SFCG wireless band is used for Wi-Fi shall not be outside the said wireless band currently allocated by SFCG (references [33] and [42]).

## **3.3 IEEE 802.11 STANDARDS**

### **3.3.1 GENERAL**

Space exploration vehicles, gateways, and planetary surface elements shall incorporate Wi-Fi infrastructure to support internal and external, low-mobility, short-range, non-critical, wireless-extended network interoperable communications.

### **3.3.2 IEEE 802.11 WI-FI**

**3.3.2.1** Infrastructure shall be compliant with Wi-Fi CERTIFIED 6™.

NOTE – Rationale: IEEE 802.11-based products are widely utilized terrestrially with a large COTS provider base and attendant reliability. IEEE 802.11ax offers very high data rates, higher quality of service, increased interference resilience, increased range, addresses hidden and exposed node issues, can be operated at 2.4 GHz or 5 GHz, and Wi-Fi CERTIFIED 6™ products have been increasingly available since late 2019.

**3.3.2.2** For 5 GHz implementations, infrastructure may be compliant with Wi-Fi CERTIFIED ac.

NOTE – Rationale: IEEE 802.11-based products are widely utilized terrestrially with a large COTS provider base and attendant reliability. IEEE 802.11ac has replaced IEEE 802.11n as the most available 5 GHz variant currently on the market supporting high-rate data communications.

**3.3.2.3** Infrastructure may be compliant with Wi-Fi CERTIFIED n.

NOTES

- 1 Rationale: IEEE 802.11-based products are widely utilized terrestrially with a large COTS provider base and attendant reliability. IEEE 802.11n was recently the most advanced 2.4 GHz variant on the market supporting mid-rate data communications and has significant space heritage.
- 2 IEEE 802.11n (Wi-Fi 4) products will quickly become obsolete and deprecated in the wireless market. Mission designers should only consider IEEE 802.11n products for legacy system maintenance and operational support.
- 3 It is the responsibility of wireless communication system planners to follow the specific Wi-Fi channel plan specified by the mission infrastructure for multi-agency interoperable wireless communications.
- 4 In support of interoperable 802-11-based Wi-Fi communications, the CCSDS leverages the interoperability test suite of the Wi-Fi Alliance. Adherence to the attendant Wi-Fi certifications and sub-certifications for Wi-Fi 4 (802.11n), Wi-Fi 5 (802.11ac), and Wi-Fi 6 (802.11ax) provides the basis for multi-agency interoperable Wi-Fi wireless communication systems. For highly mobile clients it is recommended that Wi-Fi clients support the Wi-Fi Alliance Request-to-send/Clear-to-send (RTS/CTS) certification.

**3.3.3 IEEE 802.11 SECURITY**

**3.3.3.1** For all implementations, security shall be compliant with Wi-Fi CERTIFIED WPA2-Enterprise™.

NOTE – Rationale: IEEE 802.11 based products are widely utilized terrestrially with a large COTS provider base and attendant reliability. WPA2 is recommended for backward compatibility. WPA2 is recommended to be disabled unless necessary to support legacy designs.

**3.3.3.2** For all implementations, security should be compliant with Wi-Fi CERTIFIED WPA2-Personal™.

NOTE – Rationale: IEEE 802.11-based products are widely utilized terrestrially with a large COTS provider base and attendant reliability. WPA3 is recommended for all new designs (reference [27]).

### **3.3.4 IEEE 802.11 WIRELESS PROFILES**

All client implementations should be configurable with multiple profiles (reference [29]).

NOTE – Rationale: Any client lacking support for multiple wireless profiles imposes a constraint on network configuration. Network managers may offer multiple profiles for a variety of purposes including, for example, network ownership, traffic isolation, mobility, service expansion, technology upgrades, and/or configuration maintenance. Short-duration or expendable clients may be exempted.

## **3.4 3GPP STANDARDS**

### **3.4.1 GENERAL**

**3.4.1.1** Space agency exploration communications elements shall incorporate 3GPP LTE infrastructure to support internal and external, high-mobility, mission-critical, short-to-long range, wireless interoperable network communications.

**3.4.1.2** Outside of the frequency bands used by Wi-Fi devices, implementations shall be compliant with 3GPP LTE Rel-12.

#### NOTES

- 1 It is important that implementations of a 3GPP LTE network implement network function positioning and inter-function communications to ensure that latency on each interface is as required for each mission design.
- 2 Rationale: 3GPP LTE based products are widely utilized terrestrially with a large COTS provider base and attendant reliability. 3GPP LTE offers high data rates, mission-critical quality of service, and increased interference resilience.

### **3.4.2 3GPP LTE NETWORK – EPC AND RAN**

An LTE Network shall be in the form of an Evolved Packet System (EPS) and shall be comprised of a RAN including at least one eNodeB communicating with at least one Evolved Packet Core (EPC), in accordance with 3GPP TS 23.002 LTE Network Architecture (reference [15]).

NOTE – Rationale: the RAN and EPC are required to provide communications infrastructure for UEs that need LTE access to spacecraft and planetary surface networks.

### **3.4.3 3GPP LTE NETWORK – RAN AND UE**

**3.4.3.1** The LTE Network RAN shall be comprised of UE and eNodeB devices that shall implement 3GPP TS 36.201 LTE Physical Layer (references [16] and [36]).

NOTE – Rationale: This is the LTE Physical Layer standard and provides a pathway to Release 15 (5G) and later Physical Layers in future proximity networks.

**3.4.3.2** The LTE Network RAN shall operate with a Physical Layer restricted to channel parameters, including RF frequency, bandwidth, and transmit power, listed in 3GPP TS 36.101 Radio Transmission and Reception specifications (reference [7]).

NOTE – Rationale: Modern UE and eNodeB devices are extensively tested for interoperability on these bands and with these parameters. Furthermore, signaling protocol specifications and user hardware settings use band numbers and other parameters in 3GPP TS 36.101 (reference [7]), and not direct reference to frequency and power, to specify behavior in a dynamic radio environment.

**3.4.3.3** If multi-cell operation is possible, eNodeB hardware should support S1-based HandOver (HO) according to 3GPP TS 36.413 S1 Application Protocol (reference [12]).

NOTE – Rationale: Multi-cellular operation provides an avenue for growth in capacity and coverage to allow communication over large terrains with complex line-of-sight requirements. S1-based handover is the most basic form of interoperable handover capable of ensuring that TCP/IP connections are not reset during the move from one eNodeB cell to another.

#### **3.4.4 3GPP LTE NETWORK – RAN AND MULTI-OPERATOR CORE NETWORK**

If direct sharing of the LTE RAN without further direct network interoperation is required, more than one EPC should be connected to the RAN in a Multi-Operator Core Network (MOCN) architecture, in accordance with 3GPP TS 23.251 Network Sharing (reference [13]).

NOTE – Rationale: MOCN allows supporting more than one agency directly using the shared RAN infrastructure if the corresponding eNodeB hardware is capable of supporting multiple S1 interface connections to different cores. Agencies retain full control of their networks with maximum isolation of those networks. Other techniques and infrastructure are required for agencies wishing to use lower SWaP hardware and/or deeper interoperability between their networks.

#### **3.4.5 3GPP LTE NETWORK – RAN, CORE, UE SECURITY**

LTE eNodeB, UE, and EPC implementations shall use security based on the 3GPP EPS Security Architecture, in accordance with 3GPP TS 33.401 (reference [14]).

NOTE – Rationale: LTE uses a Universal Mobile Telecommunications System (UMTS) Subscriber Identity Module (USIM) application housed on a removable Universal Integrated Circuit Card (UICC) or embedded UICC (eUICC) that provides for basic cryptographically protected identification and authentication of a UE and operator network, followed by corresponding setup of a unique per-session link encryption of the over-the-air network communications occurring between the UE and eNodeB. A UE can contain multiple USIMs corresponding to each LTE network to which the UE may wish to connect.

### **3.4.6 3GPP LTE NETWORK – RAN NETWORK IDENTIFIER, PLMN ID**

Each LTE network accessible in a mission region shall have a unique 5- or 6-digit network Public Land Mobile Network Identifier (PLMN ID). The PLMN ID shall be based on a valid 3-digit ITU-T E.212 Mobile Country Code (MCC) (reference [17]) available and registered under ITU regulations to the agency operating the LTE network, followed by a corresponding 2- or 3-digit Mobile Network Code (MNC) (reference [17]) with a value allowed for by the local regulations under which the agency operates.

#### NOTES

- 1 Rationale: Network selection is based on PLMN ID and devices cannot correctly select or connect to an LTE network if more than one network detected by a UE has the same PLMN ID.
- 2 Rationale: Many device manufacturers base device behavior for band, modulation, and transmit power selection on built-in profiles selected by MCC. Unregistered MCCs can result in a failure to discover or connect to an agency LTE network.

### **3.4.7 3GPP LTE NETWORK – UE IMSI**

Each USIM on an agency UE shall use a 15-digit International Mobile Subscriber Identifier (IMSI) that starts with the PLMN ID of the home LTE network corresponding to the SIM. The remaining 9 or 10 digits of the IMSI shall be unique for each UE in the network specified by the PLMN ID.

NOTE – Rationale: LTE networks identify, authenticate, and track UEs based on IMSI, and the IMSI must be unique for each device in the network.

### **3.4.8 3GPP LTE NETWORK – UE USIM ICCID**

A USIM installed in a UE shall have a 20-digit Integrated Circuit Card Identifier (ICCID) compatible with ITU-T E.118 Primary Account Number specification (reference [18]) that is unique for all devices in an LTE network to which the UE may connect. The ICCID shall start with the fixed Major Issuer Identifier (MII) 2-digit code, 89, followed by the 2- or 3-digit ITU-T E.164 International Public Telecommunications Numbering Plan Country Code (CC) (reference [21]) with a registered value allowed for by the local regulations under which the agency operates, followed by a 1- to 4-digit Issuer Identifier (II) code derived from the MNC of the PLMN ID of the network to which the UE will connect. All of the remaining digits of the ICCID, apart from the final digit, shall be a unique number for each device in the LTE network corresponding to the PLMN ID. The final digit shall be a check digit calculated from the other 19 digits by the Luhn Algorithm, as specified by ITU-T E.118 (reference [18]).

NOTE – Rationale: UEs must be able to tell USIMs apart and thus all USIMs must have a unique identifier. Furthermore, eUICCs may be provisioned remotely from systems providing for many different LTE network operators and UEs, and USIM identities transferred to the eUICC must have a globally unique identifier. Additionally, many device manufacturers base device behavior for band, modulation, and transmit power selection on built-in profiles selected by ICCID when MCC-based selection on PLMN ID is not possible. Unregistered CCs that are not recognized by UE firmware can result in a failure to discover or connect to an agency LTE network.

### **3.4.9 3GPP LTE NETWORK – CORE MME AND HSS**

**3.4.9.1** All LTE networks shall contain a Mobile Management Entity (MME) according to 3GPP TS 23.002 (reference [15]).

**3.4.9.2** All LTE networks shall contain Home Subscriber Server (HSS), according to 3GPP TS 23.002 (reference [15]).

NOTE – Rationale: The MME and HSS are essential for basic control-plane operation of all LTE networks.

### **3.4.10 3GPP LTE NETWORK – CORE S-GW, P-GW, COMBINED-GW**

All LTE networks shall provide at least one of either of the following user-plane architectures, according to 3GPP TS 23.002 (reference [15]):

- a) a combined Gateway (GW), or
- b) a differentiated S-GW and P-GW.

NOTE – Rationale: The gateway functionality is essential for all user-plane traffic flow in LTE networks. A system based on a differentiated S-GW/P-GW provides for more functionality and interoperability than a combined GW. LTE networks may have more than one set of gateway data flow paths to and from external data networks through different combinations of combined GW and S-GW and P-GW paths.

### **3.4.11 3GPP LTE NETWORK – CORE S1-MME AND S1-U**

**3.4.11.1** All LTE networks shall implement the S1-MME interface between each of the LTE network eNodeBs and the MME and S-GW respectively, according to 3GPP TS 23.002 (reference [15]).

**3.4.11.2** All LTE networks shall implement the S1-U interface between each of the LTE network eNodeBs and the MME and S-GW, according to 3GPP TS 23.002 (reference [15]).

NOTE – Rationale: These are the primary control and user-plane network interfaces for the RAN comprised of the eNodeBs.

### **3.4.12 3GPP LTE NETWORK – CORE S6A AND S11**

**3.4.12.1** All LTE networks shall implement the S6a interface between the MME and HSS, according to 3GPP TS 23.002 (reference [15]).

**3.4.12.2** All LTE networks shall implement the S11 interface between the MME and S-GW, according to 3GPP TS 23.002 (reference [15]).

NOTE – Rationale: These are the internal network core interfaces for providing authentication and network path selection information inside the network core.

### **3.4.13 3GPP LTE NETWORK – CORE SGI**

All LTE networks shall implement at least one SGi network interface at the combined GW or P-GW, according to 3GPP TS 23.002 (reference [15]).

NOTE – Rationale: SGi interfaces provide network port connectivity to external agency / spacecraft/surface PDNs to and from the LTE network. There may be more than one physical or virtual SGi network interface, corresponding to multiple PDNs.

### **3.4.14 3GPP LTE NETWORK – CORE SGI FOR EXTERNAL PDN**

The desired SGi for an external PDN shall be selected via the programming of an Access Point Name (APN) entry in the UE in the format specified in 3GPP TS 23.003 (reference [5]) and GSMA IR.88 (reference [11]).

NOTE – Rationale: APNs allow for the mapping of data flows for UEs and software applications on UEs to different external networks, including the ability to map UEs from different agencies to different spacecraft networks or other network infrastructure. Quality-of-Service rules can be applied on a per-APN basis.

### **3.4.15 3GPP LTE NETWORK – CORE PCEF FOR QOS CONTROL**

The GW (combined or P-GW) functionality in the LTE network shall implement a Policy and Charging Enforcement Function (PCEF) for controlling QoS.

NOTE – Rationale: QoS is critical in a spaceflight network with multiple simultaneous users and applications. The PCEF is a GW function that implements Policy and Charging Control (PCC) rules on each Service Data Flow (SDF) throughout the LTE network. The SDF is the basic unit of end-to-end managed traffic data flow for each user application session originating between UEs and external PDNs. PCC rules are used by the PCEF to tag packets in an SDF with corresponding QoS policies, which are then signaled by the PCEF to the rest of the LTE network and implemented by various components and protocols in the network.

### **3.4.16 3GPP LTE NETWORK – CORE PCEF PCF RULES FOR AUDIO**

For human missions that require voice communications, PCC rules in the LTE network shall be established so that the CCSDS 766.2-B-1 Voice and Audio Communications Recommended Standard can be implemented.

NOTE – Rationale: Voice communications are critical to mission success in human missions. CCSDS 766.2-B-1 allows this form of communication to be transported over an IP network of the form used in LTE networks. Network QoS allows an appropriate Quality-of-Experience (QoE) by mission personnel and the ability for critical voice communications to be delivered.

### **3.4.17 3GPP LTE NETWORK – CORE PCEF PCF RULES FOR VIDEO**

For missions requiring digital motion imagery, PCC rules in the LTE network should be established so that the CCSDS 776.1-B-2 Digital Motion Imagery Recommended Standard can be implemented.

NOTE – Rationale: Digital motion imagery can be critical in missions. CCSDS 776.1-B-2 allows this form of communication to be transported over an IP network of the form used in LTE networks. Network QoS allows an appropriate Quality-of-Experience (QoE) by mission personnel and the ability for critical digital motion imagery to be delivered.

## ANNEX A

### IMPLEMENTATION CONFORMANCE STATEMENT PROFORMA

#### (NORMATIVE)

#### A1 INTRODUCTION

##### A1.1 OVERVIEW

This annex provides the Protocol Implementation Conformance Statement (PICS) Requirements List (RL) for an implementation of 3GPP LTE (Release-12 minimum) (CCSDS 883.0-B-1). The PICS for an implementation is generated by completing the RL in accordance with the instructions below. An implementation claiming conformance must satisfy the mandatory requirements referenced in the RL.

The RL support column in this annex is blank. An implementation's completed RL is called the PICS. The PICS states which capabilities and options have been implemented. The following can use the PICS:

- the implementer, as a checklist to reduce the risk of failure to conform to the standard through oversight;
- a supplier or potential acquirer of the implementation, as a detailed indication of the capabilities of the implementation, stated relative to the common basis for understanding provided by the standard PICS proforma;
- a user or potential user of the implementation, as a basis for initially checking the possibility of interworking with another implementation (it should be noted that, while interworking can never be guaranteed, failure to interwork can often be predicted from incompatible PICSes);
- a tester, as the basis for selecting appropriate tests against which to assess the claim for conformance of the implementation.

##### A1.2 ABBREVIATIONS AND CONVENTIONS

The RL consists of information in tabular form. The status of features is indicated using the abbreviations and conventions described below.

###### Item Column

The item column contains sequential numbers for items in the table.

### Feature Column

The feature column contains a brief descriptive name for a feature. It implicitly means: ‘is this feature supported by the implementation?’

### Status Column

The status column uses the following notations:

M	Mandatory.
O	Optional.
O.<n>	Optional, but support of at least one of the group of options labeled by the same numeral <n> is required.
– C<n>	conditional as defined in corresponding expression below table.
– X	Prohibited.
– N/A	Not applicable.

### Support Column Symbols

The support column is to be used by the implementer to state whether a feature is supported by entering Y, N, or N/A, indicating:

Y	Yes, supported by the implementation.
N	No, not supported by the implementation.
N/A	Not applicable.

The support column should also be used, when appropriate, to enter values supported for a given capability.

## **A1.3 INSTRUCTIONS FOR COMPLETING THE RL**

An implementer shows the extent of compliance to the Recommended Standard by completing the RL; that is, the state of compliance with all mandatory requirements and the options supported are shown. The resulting completed RL is called a PICS. The implementer shall complete the RL by entering appropriate responses in the support or values supported column, using the notation described in A1.2. If a conditional requirement is inapplicable, N/A should be used. If a mandatory requirement is not satisfied, exception information must be supplied by entering a reference Xi, where i is a unique identifier, to an accompanying rationale for the noncompliance.

**A2 3GPP INTEROPERABILITY TESTING PICS PROFORMA FOR 3GPP  
 INTEROPERABILITY TESTING (CCSDS 883.0-B-1)**

**A2.1 GENERAL INFORMATION**

**A2.1.1 Identification of PICS**

Date of Statement (DD/MM/YYYY)	
PICS serial number	
System Conformance statement cross-reference	

**A2.1.2 Identification of Implementation Test Agencies**

Test Agencies	
Agency-1	
Agency-2	
Other information	

**A2.1.3 Identification of Equipment Under Test: eNB**

Equipment Under Test: eNB	
Implementation Agency	
Implementation version	
Special configuration	
Other information	

Equipment Under Test: eNB	
Implementation Agency	
Implementation version	
Special configuration	
Other information	

**A2.1.4 Identification of Equipment Under Test: UE(s)**

Equipment Under Test: UE(s)	
Implementation Agency	
Implementation version	
Special configuration	
Other information	

Equipment Under Test: UE(s)	
Implementation Agency	
Implementation version	
Special configuration	
Other information	

**A2.1.5 Identification of Equipment Under Test: Core**

Equipment Under Test: Core	
Implementation Agency	
Implementation version	
Special configuration	
Other information	

Equipment Under Test: Core	
Implementation Agency	
Implementation version	
Special configuration	
Other information	

**A2.1.6 SD-WAN Configuration (Optional)**

SD-WAN	
Implementation Agency	
Special configuration	
Other information	

SD-WAN	
Implementation Agency	
Special configuration	
Other information	

**A2.1.7 Identification of Specification**

CCSDS 883.0-B-1	
Have any exceptions been required?	Yes [ ]      No [ ]
<p>NOTE – A YES answer means that the implementation does not conform to the Recommended Standard. Non-supported mandatory capabilities are to be identified in the PICS, with an explanation of why the implementation is nonconforming.</p>	

Item Number	Item Description	Reference	Status Value	Support	Protocol Status Value	Profile Status Value
1	3GPP LTE EPC & RAN (non-ISM)	3.4.1	M			
2	3GPP LTE EPC and RAN	3.4.2	M			
3	3GPP LTE EPC and UE LTE PHY	3.4.3	M			
4	3GPP LTE EPC and UE S1-based HO	3.4.3	M/O			
5	3GPP LTE RAN and MOCN	3.4.4	O			

**CCSDS HISTORICAL DOCUMENT**  
**RECOMMENDED STANDARD FOR WIRELESS PROXIMITY NETWORK COMMUNICATIONS**

<b>Item Number</b>	<b>Item Description</b>	<b>Reference</b>	<b>Status Value</b>	<b>Support</b>		<b>Protocol Status Value</b>	<b>Profile Status Value</b>
6	3GPP LTE RAN, Core, UE Security	3.4.5	M				
7	3GPP LTE RAN PLMN ID	3.4.6	M				
8	3GPP LTE UE IMSI	3.4.7	M				
9	3GPP LTE UE USIM ICCID	3.4.8	M				
10	3GPP LTE Core MME and HSS	3.4.9	M				
11	3GPP LTE Core S-GW and P-GW	3.4.10	M				
12	3GPP LTE Core S1-MME and S1-U	3.4.11	M				
13	3GPP LTE Core S6a and S11	3.4.12	M				
14	3GPP LTE Core SGi	3.4.13	M				
15	3GPP LTE Core SGi for Ext-PDN	3.4.14	M				
16	3GPP LTE Core PCEF for QoS	3.4.15	M				
17	3GPP LTE Core PCEF PCF for Audio	3.4.16	O				
18	3GPP LTE Core PCEF PCF for Video	3.4.17	O				

**A3 3GPP INTEROPERABILITY TESTING PICS PROFORMA FOR *IEEE 802.11 (WI-FI)* (CCSDS 883.0-B-1)**

**A3.1 GENERAL INFORMATION**

**A3.1.1 Identification of PICS**

Date of Statement (DD/MM/YYYY)	
PICS serial number	
System Conformance statement cross-reference	

**A3.1.2 Identification of Implementation Test Agencies**

Test Agencies	
Agency-1	
Agency-2	
Other information	

**A3.1.3 Identification of Equipment Under Test: AP**

Equipment Under Test: Access Point (AP)	
Implementation Agency	
Implementation version	
Special configuration	
Other information	

Equipment Under Test: Access Point (AP)	
Implementation Agency	
Implementation version	
Special configuration	
Other information	

**A3.1.4 Identification of Equipment Under Test: UE(s)**

<b>Equipment Under Test: UE(s)</b>	
Implementation Agency	
Implementation version	
Special configuration	
Other information	

<b>Equipment Under Test: UE(s)</b>	
Implementation Agency	
Implementation version	
Special configuration	
Other information	

**A3.1.5 SD-WAN Configuration (Optional)**

<b>SD-WAN</b>	
Implementation Agency	
Special configuration	
Other information	

<b>SD-WAN</b>	
Implementation Agency	
Special configuration	
Other information	

**A3.1.6 Identification of Specification**

CCSDS 883.0-B-1	
Have any exceptions been required?	Yes [ ]      No [ ]
NOTE – A YES answer means that the implementation does not conform to the Recommended Standard. Non-supported mandatory capabilities are to be identified in the PICS, with an explanation of why the implementation is nonconforming.	

Item Number	Item Description	Reference	Status Value	Support		Protocol Status Value	Profile Status Value
1	IEEE 802.11ax Wi-Fi 6	3.3.2	M				
2	IEEE 802.11ax Wi-Fi 5	3.3.2	O				
3	IEEE 802.11ax Wi-Fi 4	3.3.2	O				
4	WPA2™	3.3.3	O				
5	WPA3™	3.3.3	M				
6	IEEE 802.11 Profiles	3.3.4	M				

**A4 TEST ARTIFACT GENERATION FOR 3GPP INTEROPERABILITY TESTING**

This document describes the procedure for the following:

- a) 3GPP LTE Network connectivity verification;
- b) 3GPP LTE Network performance characterization;
- c) 3GPP LTE QoS verification;
- d) 3GPP LTE Mobility verification.

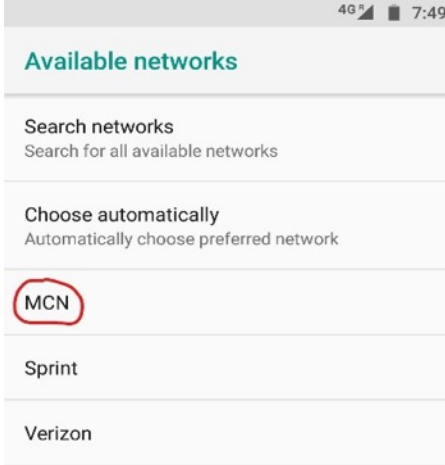
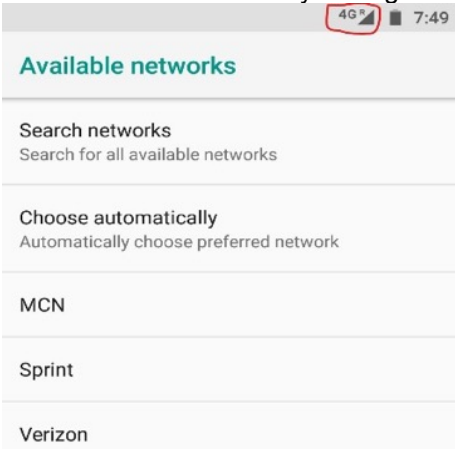
Network Connectivity Verification Procedure	
<b>Detection of LTE network</b>	<ul style="list-style-type: none"> <li>– Go to settings</li> <li>– Go to Network and Internet</li> <li>– Go to Mobile network</li> <li>– Go to Network operators</li> <li>– Search networks to see the list</li> </ul> 
<b>UE Register to LTE network</b>	<ul style="list-style-type: none"> <li>– Can be verified by the signal logo at the top</li> </ul> 
<b>UE backhaul to Internet</b>	<ul style="list-style-type: none"> <li>– Can be verified by clicking on the browser and going to a website (e.g., <a href="http://www.nasa.gov">www.nasa.gov</a>)</li> </ul>
<b>Other information</b>	n/a

Precursors for network performance verification are to:

- ensure the eNBs and the core are connected and powered on;
- ensure the RF and Status LED on the eNBs are ‘green’ for nominal operation;
- ensure that the UE is connected to the LTE network, indicated by the signal bar on the UE.

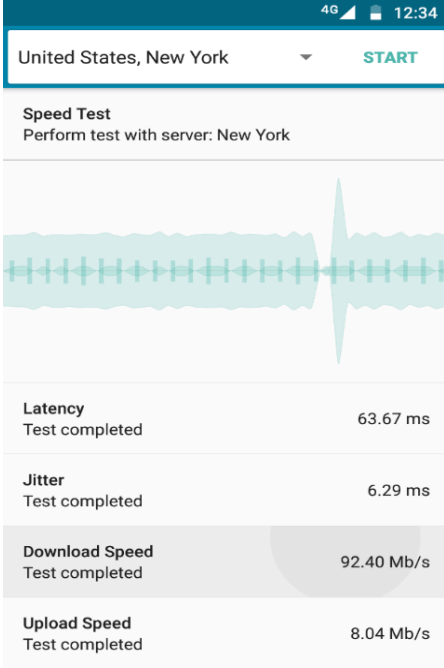
Network Performance Verification Procedure	
Test Description	Test documentation
<b>Speed Test</b>	<ul style="list-style-type: none"> <li>- Download PingTools (version 4.35 and above) from the app/play store. Link: <a href="https://play.google.com/store/apps/details?id=ua.com.streamsoft.pingtools&amp;hl=en_US">https://play.google.com/store/apps/details?id=ua.com.streamsoft.pingtools&amp;hl=en_US</a></li> <li>- Open the PingTools app.</li> <li>- Click the tab on the top-left and select speed test.</li> <li>- Choose 'determine server automatically' and start.</li> </ul> <p><u>Sample output:</u></p>  <p style="text-align: right;">Signature:</p>

<p><b>iPerf Test</b></p>	<ul style="list-style-type: none"> <li>- Download Magic iPerf (version 1.0 and above) from the app/play store. Link: <a href="https://play.google.com/store/apps/details?id=com.nextdoordeveloper.miperf.miperf&amp;hl=en_US">https://play.google.com/store/apps/details?id=com.nextdoordeveloper.miperf.miperf&amp;hl=en_US</a></li> <li>- Open the Magic iPerf app.</li> <li>- To start iPerf server, enter the command '-s -i 1' in one of the UEs.</li> <li>- To client iPerf client, enter the command '-c -i 1 &lt;ip_address_of_server&gt;' in the other UE.</li> <li>- Flip the switch on the top-right to start the server and client.</li> </ul> <p>Sample server output:</p>  <p>Sample client output:</p>  <p style="text-align: right;">Signature:</p>
<p><b>Other information</b></p>	<p>n/a</p>

QoS Verification Procedure	
Test Description	Test documentation
<b>Other information</b>	n/a

Mobility Verification Procedure	
Test Description	Test documentation
<b>Handover during video call</b>	<ul style="list-style-type: none"> <li>- Download a video conference app, Zoom (version 4.4 and above), from the app/play store. Link: <a href="https://play.google.com/store/apps/details?id=us.zoom.videomeetings&amp;hl=en_US">https://play.google.com/store/apps/details?id=us.zoom.videomeetings&amp;hl=en_US</a></li> <li>- Set up a second eNB at a certain distance from the first eNB such that the signal coverage areas from both eNBs slightly overlap each other.</li> <li>- The distance can be roughly estimated by moving the UE away from one eNB and observing the distance at which the signal strength drops by half, as seen in the signal bar icon on the UE, and by placing the second eNB at double the observed distance.</li> <li>- Open the zoom app on both the UEs.</li> <li>- Start a zoom meeting on one UE and join the meeting on the other UE by entering the meeting ID.</li> <li>- Tap on the 'start video' button to start the video transmission.</li> <li>- Place one UE near one of the eNBs and walk with the other UE from one eNB to the other, to initiate handover, all while streaming the video.</li> <li>- Video call must not drop significantly to ensure seamless handover of UE from one eNB to the other.</li> </ul> <p><u>Sample video output:</u></p> <div style="text-align: center;">  <p>zoom_recording.mp4</p> </div> <p style="text-align: right;">Signature:</p>
<b>Other information</b>	n/a

<b>Testing Notes</b>	
<b>Test Note 01</b>	iPerf test is applicable only to Wi-Fi, since LTE core does not allow UEs to directly ping each other.
<b>Test Note 02</b>	The test procedure for every interop scenario needs to be performed.
<b>Test Note 03</b>	Handover output is shown by recording the screen during video conference. Video conference is used for live streaming, which is used to avoid background video prefetching (i.e., caching).

## **A5 TEST ARTIFACT GENERATION FOR IEEE 802.11**

### **ExWC Wi-Fi Roaming Test Procedure**

This document describes the Wi-Fi roaming test procedure as follows:

- a) Network connectivity verification;
- b) Network performance verification.

Once a UE has been connected to a Wi-Fi network, the Wi-Fi network credentials, Service Set Identifier (SSID), which are the network's name and the network's password, will be stored in the UE. The UE can then connect to any Wi-Fi network with the same credentials irrespective of the network location or vendor, thereby allowing roaming.

<b>Network Connectivity Verification Procedure</b>	
<b>Test Description</b>	<b>Test documentation</b>
<b>Wi-Fi saved networks</b>	<ul style="list-style-type: none"> <li>– Go to settings.</li> <li>– Go to Wi-Fi.</li> <li>– Go to Saved networks.</li> <li>– Verify that the list of saved networks includes the Wi-Fi network of interest.</li> </ul>
<b>Connecting to the Wi-Fi network</b>	<ul style="list-style-type: none"> <li>– The UE automatically connects to the previously known Wi-Fi network.</li> <li>– UE can also be manually connected to the Wi-Fi by going to Settings -&gt; Wi-Fi and selecting the Wi-Fi network of interest.</li> </ul>
<b>UE access to the Internet</b>	<ul style="list-style-type: none"> <li>– Access can be verified by clicking on the browser and going to a website (e.g., <a href="http://www.nasa.gov">www.nasa.gov</a>).</li> </ul>

Network Performance Verification Procedure	
Test Description	Test documentation
iPerf test	<ul style="list-style-type: none"><li>– Download PingTools Network Utilities (version 4.35 and above) from the app/play store.</li></ul> <p><u>Link:</u> <a href="https://play.google.com/store/apps/details?id=ua.com.streamsoft.pingtools&amp;hl=en_US">https://play.google.com/store/apps/details?id=ua.com.streamsoft.pingtools&amp;hl=en_US</a></p> <ul style="list-style-type: none"><li>– Open the PingTools application on the UE.</li><li>– Click the tab on the top-left and select iPerf.</li><li>– Enter the iPerf server IP address and click start.</li></ul> <p>Signature:</p>

Testing Notes	
Test Note 01	A UE with Android OS is used as an example in the procedure.

## ANNEX B

### SECURITY, SANA, PATENT CONSIDERATIONS

#### (INFORMATIVE)

##### B1 SECURITY CONSIDERATIONS

IEEE 802.11 and 3GPP LTE are datalink protocols that transport network traffic. Security provision for operational systems, terrestrial or extra-terrestrial, is part of the exploration mission communication architect responsibilities. Security services can be implemented at the PHY, Datalink, Network, Transport, and Application Layers of the OSI protocol stack. It is the mission designer's choice where, to what extent, and how flexibly (optional vs. mandatory) security features are deployed and required.

Security provisions follow industry standards for the two recommended proximity wireless network communications technologies recommended in this document: IEEE 802.11-based Wi-Fi, and, 3GPP-based LTE and security implementations are part of the respective standards-based product ecosystems.

For Wi-Fi products, the security standard is Wi-Fi Protected Access (WPA) version 3 (WPA3). WPA and WPA2 were previous versions of the standard, and along with WPA3, all are based upon IEEE 802.11i (reference [31]). WPA3, which retains interoperability with WPA2™ devices, is currently a mandatory certification for Wi-Fi CERTIFIED devices.

For 3GPP LTE/5G, the comprehensive security suite and security provisioning is defined in 3GPP TS 33.401 (reference [14]). Additional information is contained in this document's Identity and Security Specifications in section 3:

- 3.4.5, 3GPP LTE Network – RAN, Core, UE Security;
- 3.4.6, 3GPP LTE Network – RAN Network Identifier, PLMN ID;
- 3.4.7, 3GPP LTE Network – UE IMSI;
- 3.4.8, 3GPP LTE Network – UE USIM ICCID;
- 3.4.9, 3GPP LTE Network – Core MME and HSS.

##### B2 SANA CONSIDERATIONS

###### B2.1 INTRODUCTION

The recommendations in this document have created or modified the following SANA registries located at <http://sanaregistry.org>.

**B2.2 NEW REGISTRIES**

**B2.2.1 New registry – Wireless proximity Network ID (WPNIID)**

WPNIID = ‘00000000’ to ‘11111111’ (see table B-1).

Status = Managed.

Reference: CCSDS 883.0-B-1.

**Table B-1: Wireless Proximity Networking Identifiers**

Wireless Proximity Network Protocol	WPNIID (base 10)	WPNIID (base 2)
Reserved	0	‘0000 0000’
IEEE 802.11b	1	‘0000 0001’
IEEE 802.11g	2	‘0000 0010’
IEEE 802.11n	3	‘0000 0011’
IEEE 802.11ac	4	‘0000 0100’
IEEE 802.11ad	5	‘0000 0101’
IEEE 802.11ah	6	‘0000 0110’
IEEE 802.11ax	7	‘0000 0111’
IEEE 802.11ay	8	‘0000 1000’
IEEE 802.11be	9	‘0000 1010’
	10 – 127 unused	‘0000 1010’ – ‘0111 1111’
3GPP LTE Release-12	128	‘1000 0000’
3GPP LTE Release-13	129	‘1000 0001’
3GPP LTE Release-14	130	‘1000 0010’
3GPP 5G Release-15	131	‘1000 0011’
3GPP 5G Release-16	132	‘1000 0100’
3GPP 5G Release-17	133	‘1000 0101’
3GPP 5G Release-18	134	‘1000 0110’
	135 – 254 unused	‘1000 0111’ – ‘1111 1110’
Reserved	255	‘1111 1111’

### **B2.2.2 New registry – PLMN**

The PLMN ID shall be based on a valid 3-digit ITU-T E.212 Mobile Country Code (MCC) available and registered under ITU regulations to the agency operating the LTE network, followed by a corresponding 2- or 3-digit Mobile Network Code (MNC) with a value allowed for by the local regulations under which the agency operates.

Status = Managed.

Reference: CCSDS 883.0-B-1.

### **B2.2.3 New registry – USIM**

Each USIM on an agency UE shall use a 15-digit International Mobile Subscriber Identifier (IMSI) that starts with the PLMN ID of the home LTE network corresponding to the SIM. The remaining 9 or 10 digits of the IMSI shall be unique for each UE in the network specified by the PLMN ID.

A USIM installed in a UE shall have a 20-digit Integrated Circuit Card Identifier (ICCID) compatible with ITU-T E.118 Primary Account Number specification that is unique for all devices in an LTE network to which the UE may connect. The ICCID shall start with the fixed major issuer identifier (MII) 2-digit code, 89, followed by the 2- or 3-digit ITU-T E.164 International Public Telecommunications Numbering Plan Country Code (CC) with a registered value allowed for by the local regulations under which the agency operates, followed by a 1- to 4-digit Issuer Identifier (II) code derived from the MNC of the PLMN ID of the network to which the UE will connect. All of the remaining digits of the ICCID, apart from the final digit, shall be a unique number for each device in the LTE network corresponding to the PLMN ID. The final digit shall be a check digit calculated from the other 19 digits by the Luhn Algorithm, as specified by ITU-T E.118.

Status = Managed.

Reference: CCSDS 883.0-B-1.

## **B2.3 MODIFIED REGISTRY—CCSDS ABBREVIATIONS**

Abbreviation: PLMN – Public Land Mobile Network.

Abbreviation: MCC – Mobile Country Code.

Abbreviation: MNC – Mobile Network Code.

Abbreviation: SIM – Subscriber Identity Module.

Abbreviation: UMTS – Universal Mobile Telecommunications System.

Abbreviation: USIM – UMTS Identity Module.

Abbreviation: IMSI – International Mobile Subscriber Identifier.

Abbreviation: ICCID – Integrated Circuit Card Identifier (ICCID).

Abbreviation: CC – International Public Telecommunications Numbering Plan Country Code.

Reference: CCSDS 883.0-B-1.

### **B3 PATENT CONSIDERATIONS**

It is expected that implementation of this Recommended Standard by space-agency users will occur through the use of commercial off-the-shelf equipment that implements the referenced standards, and that patent-rights issues for such equipment will have been settled between the equipment manufacturer and the patent-right holders.

## ANNEX C

# WIRELESS PROXIMITY NETWORK COMMUNICATIONS TECHNOLOGIES

## (INFORMATIVE)

### C1 INTRODUCTION

This annex provides a technical overview of the wireless proximity network communications standards recommended in this document:

- a) IEEE 802.11 (Wi-Fi);
- b) 3GPP Long-Term Evolution (LTE).

Detailed technical information is specified in the *Wireless Network Communications Overview for Space Mission Operations* (reference [E1]).

### C2 IEEE 802.11 (WI-FI) OVERVIEW AND EVOLUTION

#### C2.1 OVERVIEW

Detailed technical information for IEEE 802.11 ‘Wi-Fi’ (Wireless Fidelity) Wireless Local Area Networks (WLAN) is specified in subsection 5.1.5 of the *Wireless Network Communications Overview for Space Mission Operations* (reference [E1]). Additional relevant background information is contained in Interop Testing Considerations for IEEE 802.11 annex in Yellow Book report (reference [E16]), Spectrum Management Concerns annex in reference [E1], and the Scalable Architecture for Wi-Fi Protocols annex in reference [E1].

IEEE 802.11 standards have undergone significant evolution since reference [E1], which was based on IEEE 802.11-2012 and some additional standards soon after the IEEE 802.11-2012 release. This annex provides a discussion of changes to the IEEE 802.11 standards relevant to space applications.

There are seven different Physical Layers defined in 802.11-2012, but only two are still in common use: The Orthogonal Frequency Division Modulation (OFDM) PHY, which encompasses essentially what used to be 802.11a and 802.11g, and the High Throughput (HT) PHY, which encompasses 802.11n. The HT PHY is itself just a MIMO version of the OFDM PHY that supports up to four separate data streams using spatial multiplexing and MIMO beamforming. In addition, both the 802.11ac and 802.11ad amendments incorporate Physical Layers based on the OFDM PHY.

## **C2.2 OFDM PHY**

The OFDM PHY provides Physical Layer data rates of 6, 9, 12, 18, 24, 36, 48, and 54 Mb/s on 20 MHz channels. The system uses 64 subcarriers, of which 48 are modulated with data. The remaining subcarriers are either modulated with pilot signals or set to zero to serve as guard bands. The data are modulated using binary or quadrature phase shift keying (BPSK or QPSK) or using 16- or 64-quadrature amplitude modulation (16-QAM or 64-QAM). Forward error correction convolutional coding is used with coding rates of 1/2, 2/3, or 3/4, and an 800 ns Guard Interval (GI) in the form of a cyclic prefix is appended to all OFDM symbols. The OFDM PHY also provides ‘half-clocked’ data rates of 3, 4.5, 6, 9, 12, 18, 24, and 27 Mb/s on 10 MHz channels and ‘quarter-clocked’ data rates of 1.4, 2.25, 3, 4.5, 6, 9, 12, and 13.5 Mb/s on 5 MHz channels. Half-clocked operation on 10 MHz channels doubles the OFDM symbol times and Clear Channel Assessment (CCA) times and quarter-clocked operation on 5 MHz channels quadruples the OFDM symbol times and CCA times. The OFDM PHY is defined for use in both the 2.4 GHz ISM band and the 5 GHz UNII band.

## **C2.3 IEEE 802.11N HIGH THROUGHPUT PHY**

The High Throughput (HT) PHY is based on the OFDM PHY extended to MIMO systems with at most 4 transmit and receive antennas. Transmission on up to four *spatial streams* is defined for operation on channels with 20 MHz bandwidth. In addition, transmission on one to four spatial streams is defined for channels with 40 MHz bandwidth (sometimes called *channel bonding*). These features are capable of supporting data rates up to 600 Mb/s (four spatial streams, 40 MHz bandwidth).

For the HT PHY, there are a large number of possible data rates corresponding to the various combinations of modulation, coding scheme, GI, and number of spatial streams ( $N_{ss}$ ). Each of the possible combinations is designated by a Modulation and Coding Scheme (MCS) index between 0 and 76.

## **C2.4 802.11AC VERY HIGH THROUGHPUT PHY**

The Very High Throughput (VHT) PHY is based on the HT PHY, which in turn is based on the OFDM PHY; however, the VHT PHY is defined for use only in the 5 GHz UNII band. The VHT PHY extends the maximum number of space-time streams supported to eight and provides support for Multi-User (MU) transmissions. A MU transmission supports up to four users with up to four space-time streams per user, with the total number of space-time streams not exceeding eight.

The VHT PHY provides support for 20 MHz, 40 MHz, 80 MHz, and 160 MHz contiguous channel bandwidths and support for 80+80 MHz non-contiguous channel bandwidth. For a 20 MHz VHT transmission, the 20 MHz is divided into 64 subcarriers, with a maximum data rate on a 20 MHz channel of 693.3 Mb/s. For a 40 MHz VHT transmission, the maximum data rate is 1.6 Gb/s. For an 80 MHz VHT transmission, the 80 MHz is divided into 256 subcarriers and the maximum data rate is 3.4667 Gb/s. For a 160 MHz VHT transmission, the 160 MHz is

divided into 512 subcarriers, and the maximum data rate is 6.9333 Gb/s. For a non-contiguous 80+80 MHz VHT transmission, each 80 MHz frequency segment is divided into 256 subcarriers with a maximum data rate on an 80+80 MHz channel is also 6.9333 Gb/s.

## **C2.5 IEEE 802.11-2020**

Since 2012, many of the IEEE 802.11 standards have been rolled up in one single standard, up to 2020, as IEEE 802.11-2020 (reference [1]). Many IEEE 802.11 standards are included in IEEE 802.11-2020, including IEEE 802.11ac and IEEE 802.11ad. The new standard also includes the removal of obsolete functions.

## **C2.6 IEEE 802.11AD REDUCED PERFORMANCE**

The version of 802.11ad technology in IEEE 802.11-2020 supersedes the OFDM PHY described in reference [E1]. Channel bandwidth has been increased from 1.88 GHz to 2.16 GHz. Two more channels have been added at 66.96 GHz and 69.12 GHz. Maximum data rates are now reduced to 4.620 Gb/s instead of 6.757 Gb/s, using the new PHY layer. The obsolescence of the OFDM PHY was primarily the result of a lack of implementation by vendors. The IEEE 802.11ad standard has not become a significantly deployed technology for consumers, but the technology is undergoing enhancement for future IEEE standards. The technology is used as the basis of commercial Enterprise-grade solutions that take advantage of the ability to construct up to 32-antenna beamforming arrays at small volume using the standard, operating at 60 GHz.

## **C2.7 IEEE 802.11AY 100 GB/S-CLASS WIRELESS COMMUNICATIONS**

After the partial success of IEEE 802.11ad (WiGig), a standard is in development to allow for communications at ranges of 300 to 500 meters, and with data rates exceeding 100 Gb/s. This standard, IEEE 802.11ay, due for release in December 2020, has developed from initial requirements of 20 Gb/s, but improvements have been driven by rapidly developing user requirements, as described in reference [E2]. Draft versions of IEEE 802.11ay are already available in chipsets, which are a component of Facebook Terragraph research into high-speed wireless meshing (reference [E3]).

IEEE 802.11ay builds upon the 2012 version of IEEE 802.11ad. The original obsoleted IEEE 802.11ad OFDM MAC, plus other enhancements, bring the single-stream operating data rate per 2.16 GHz channel up to 11 Gb/s. However, 4 streams over MIMO are now allowed, in addition to the existing beamforming-only approach in IEEE 802.11ad, which brings per-channel performance up to 44 Gb/s. Finally, like 3GPP, up to four IEEE 802.11ad 60 GHz-band channels may be combined, for a total aggregate bandwidth of 8.64 GHz and 176 Gb/s of maximum throughput. This promises a very high-rate wireless communication technology with reasonable range, but with low-penetration through walls. Like 3GPP standards, the OFDM multipath resilience, MIMO, and beamforming of IEEE 802.11ay will allow for communication around blockage when multipath is available.

## C2.8 IEEE 802.11AX HIGH EFFICIENCY WLAN

IEEE 802.11ax (see reference [E4]) represents the progression from IEEE 802.11ac and is also due to be finalized in late 2020 (see reference [E5]), although a Wi-Fi certification program has been operating since September 2019 as Wi-Fi CERTIFIED 6™. Unlike IEEE 802.11ac, the improvements in IEEE 802.11ax allow for initial operation in both 2.4 GHz and 5.8 GHz with plans to allow for eventual operation at other bands between 1 GHz and 7 GHz.

A major change in IEEE 802.11ax over previous IEEE 802.11 standards is to adopt OFDMA scheduled communications, with resource units, the equivalent of 3GPP LTE and 5G resource blocks, being scheduled in frequency, time, and spatial channels. This allows for contention-free communications that are appropriate to high-density multi-AP networks, allowing Wi-Fi networks to behave more like cellular networks.

Modulation is increased from 256-QAM to 1024-QAM, but symbol time is increased from 3.2 μs to 12.8 μs, with guard interval selectable up to 3.2 μs (from a previous maximum of 0.8 μs), giving increased multipath resistance and symbol energy to noise ratio. The result is an increase of maximum data rate from 7 Gb/s in IEEE 802.11ac to 9.6 Gb/s in IEEE 802.11ax. The multipath resistance allows for a 16-fold improvement in range in high-multipath environments at high data rates.

MU-MIMO is now allowed on both downlink (as in IEEE 802.11ac) and uplink. Power usage is also reduced by use of Target Wake Time (TWT) (originally developed for IEEE 802.11ah), in which devices may sleep and then wake up for transmission. This can occur at times other than the beacon time, which then also reduces contention for RF spectrum, contributing to dense network deployment of the standard.

Pre-standard versions of IEEE 802.11ax have been available from vendors since August 2017 with true Wi-Fi CERTIFIED 6™ products available since late 2019. The technology represents a natural evolution of IEEE 802.11-2012 that can support significantly higher levels of mission reliability than the IEEE 802.11n and 802.11ac-class standards.

## C2.9 IEEE 802.11BE EXTREMELY HIGH THROUGHPUT

**IEEE 802.11be** Extremely High Throughput (EHT) is the potential next amendment of the 802.11 IEEE standard. It will build upon 802.11ax, focusing on WLAN indoor and outdoor operation with stationary and pedestrian speeds in the 2.4, 5, and 6 GHz frequency bands. Being the potential successor of Wi-Fi 6, the Wi-Fi Alliance will most likely certify it as **Wi-Fi 7**.

So far, the main candidate features that have been discussed for 802.11be are: 320 MHz bandwidth and more efficient utilization of non-contiguous spectrum; multi-band/multi-channel aggregation and operation, 16 spatial streams, and Multiple Input Multiple Output (MIMO) protocols enhancements; multi-Access Point (AP) Coordination (e.g., coordinated and joint transmission); Enhanced link adaptation and retransmission protocol (e.g., Hybrid Automatic Repeat Request [HARQ]); if needed, adaptation to regulatory rules specific to 6 GHz spectrum; and Integrating Time-Sensitive Networking (TSN) extensions for low-latency real-time traffic (IEEE 802.11aa).

## **C2.10 IEEE 802.11AH-2016 WI-FI HALOW**

An offshoot of the older IEEE 802.11-2007 standards, which precede IEEE 802.11n, the 2016 Wi-Fi HaLow standard (reference [2]) is designed to support longer range and lower electrical power communications by use of bands in the vicinity of 900 MHz, for Internet-of-Things (IoT) applications. Communication is based on the IEEE 802.11a and IEEE 802.11g protocols, with some modifications. To fit within the narrow bandwidths available at 900 MHz, the standard works on a sub-sampled variant of the IEEE 802.11-2007 standards. Only 26 OFDM sub-channels are used, down from 52, but in a 16 MHz total channel width, compared to 22 MHz for IEEE 802.11g. Unlike IEEE 802.11a and IEEE 802.11g, IEEE 802.11ah allows 4 MIMO streams, allows up to 347 Mb/s data rates, and can operate at ranges above 1 kilometer. IEEE 802.11ah HaLow will support WPA3 security.

## **C2.11 IEEE 802.11 NETWORK AUTHENTICATION**

Wi-Fi network access can be controlled and administered via IEEE 802.1x port-based Network Access Control. IEEE 802.1X (reference [22]) defines the encapsulation of the Extensible Authentication Protocol (EAP) over IEEE 802. With IEEE 802.1x systems, Remote Authentication Dial-In User Service (RADIUS) is often the back-end of choice for authentication. RADIUS is a client/server protocol that runs at the Application Layer utilizing either UDP or TCP for transport, and provides authentication, authorization, and accounting management services. Network access servers, the gateways that control access to a network, usually contain a RADIUS client component that communicates with the RADIUS server. WPA2 and WPA3 with IEEE 802.1x authentication are known as WPA2-Enterprise and WPA3-Enterprise. Enterprise variants of WPA2 and WPA3 do not suffer from the management and security exposure problems of pre-shared keys.

## **C3 3GPP EVOLUTION**

### **C3.1 OVERVIEW**

Detailed technical information for 3GPP Long Term Evolution (LTE) is specified in reference [E1]. Additional technical information is contained in Interop Testing Considerations for 3GPP LTE in the associated Yellow Book Interoperability Testing Report (reference [E16]), Interoperability Considerations (SD-WAN) annex in reference [E1], Spectrum Management Concerns in reference [E1], annex D, Network Management in 3GPP Networks annex in reference [E1], and annex G of this document.

The architecture of the 3GPP Long Term Evolution (LTE) proximity wireless communications is shown in figure C-1. The primary LTE functional components that constitute the RAN and the Evolved Packet Core (EPC) are:

- Mobility Management Entity (MME): Supports user equipment context, identity, authentication, and authorization.
- S-GW: Receives and sends packets between the eNodeB and the core network.

- P-GW: Connects the EPC with external networks.
- Home Subscriber Server (HSS): Database of user-related and subscriber-related information.
- Policy and Charging Rules Function (PCRF): Optional function providing QoS rules to P-GW.

NOTE – S-GW and P-GW may be implemented as a single combined gateway for simplified user-plane applications.

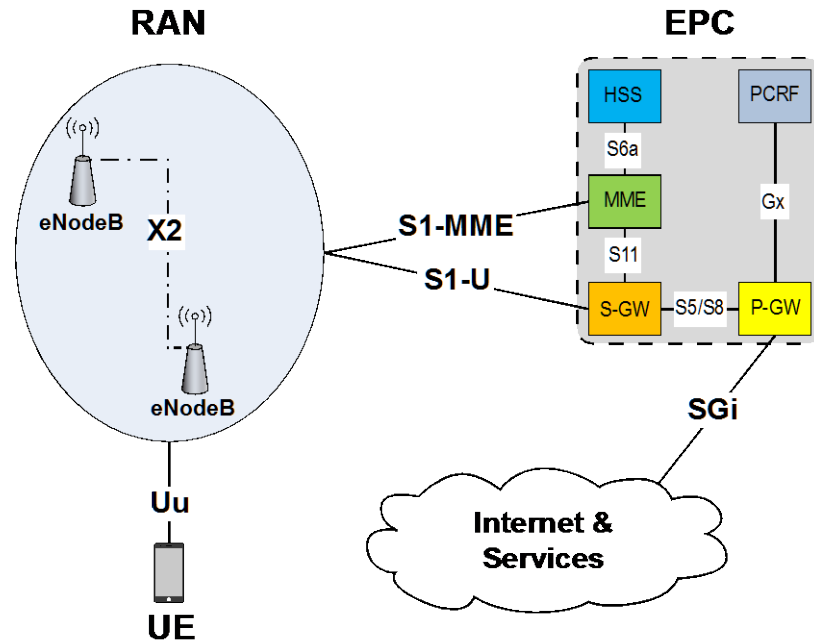

**Figure C-1: Basic 3GPP Long Term Evolution (LTE) Architecture**

Interfaces (more than one instance of each interface can exist):

- [Required] Uu: The RF interface and carried protocols between a UE and the eNodeBs.
- [Required] S1 interface between the E-UTRAN and the EPC: For both control purposes and for user plane data traffic. S1-MME is the control-plane component of this interface, and S1-U is the user-plane component. S1-U connection information is provided on a per-user data flow connection basis to eNodeBs via S1-MME.
- [Optional] X2 interface for eNodeBs to interact with each other: Again for both control purposes and for user plane data traffic.
- [Required] S6a interface between HSS and MME for authentication and provisioning information for UEs.

- [Required] S11 interface between MME and S-GW providing control-plane information for user data flows, including information from MME originating in HSS.
- [Optional] S5/S8 interface between S-GW and P-GW carrying user-plane and control-plane information. S8 is the roaming variant of S5 for communication between different EPCs. Required if gateway functions are fully differentiated between S-GW and P-GW, or if combined gateway is routing traffic to another, or external, P-GW.
- [Optional] Gx interface between PCRF and P-GW carrying control-plane messages to P-GW to regulate QoS of user-plane traffic flow.
- [Required] SGi interface between P-GW and external PDN carrying user-plane traffic flow to external services.

### **C3.2 LTE EVOLUTION TOWARD 5G**

Since reference [E1], 3GPP 4<sup>th</sup> Generation LTE technology has advanced considerably and has become the dominant form of mobile high-speed data communications. However, the first full 3GPP 5<sup>th</sup> Generation (5G) 3GPP technology standards have been completed, and 5G networks are now being deployed to consumers, having started to become operational in October 2018. Table C-1 details the timeline and capabilities evolution of 3GPP LTE and 5G. This annex subsection describes important advances and changes that are crucial to near-term use of 3GPP standards in spaceflight proximity wireless networks.

**Table C-1: 3GPP LTE and 5G Capabilities by Release**

Release	Status	Start	End	Capabilities and Services
<b>Rel-17</b>	Open	2018-06-15		Topics include: Cyber-physical control systems, mission critical services common requirements, critical medical applications, enhancements for UAVs, asset tracking use cases, enhanced relays, future railway mobile communication system, edge computing enhancement for 5G networks, and proximity services enhancements.
<b>Rel-16</b>	Open	2017-03-22	2020-07-03	Topics include: Multimedia Priority Service, Vehicle-to-everything (V2X) Application Layer services, 5G satellite access, Local Area Network support in 5G, wireless and wireline convergence for 5G, terminal positioning and location, and novel radio techniques. Also security, codecs and streaming services, Local Area Network interworking, network slicing, and the IoT.
<b>Rel-15</b>	Frozen	2016-06-01	2019-06-07	First NR ('New Radio') release. Support for 5G Vehicle-to-x service, IP Multimedia Core Network Subsystem (IMS), Future Railway Mobile Communication System.
<b>Rel-14</b>	Frozen	2014-09-17	2017-06-09	Energy Efficiency, Location Services (LCS), Mission Critical Data over LTE, Mission Critical Video over LTE, Flexible Mobile Service Steering (FMSS), Multimedia Broadcast Supplement for Public Warning System (MBSP), enhancement for TV service, massive Internet of Things, Cell Broadcast Service (CBS).
<b>Rel-13</b>	Frozen	2012-09-30	2016-03-11	LTE in non-licensed bands, LTE enhancements for Machine-Type Communication. Elevation Beamforming/Full-Dimension MIMO, Indoor positioning. LTE-Advanced Pro.
<b>Rel-12</b>	Frozen	2011-06-26	2015-03-13	Enhanced Small Cells (higher order modulation, dual connectivity, cell discovery, self-configuration), Carrier aggregation (2 uplink carriers, 3 downlink carriers, FDD/TDD carrier aggregation), MIMO (3D channel modeling, elevation beamforming, massive MIMO), New and Enhanced Services: MTC, D2D comms, eMBMS.
<b>Rel-11</b>	Frozen	2010-01-22	2013-03-06	Advanced IP Interconnection of Services. Service layer interconnection between national operators/carriers as well as third party application providers heterogeneous networks (HetNet) improvements, Coordinated Multi-Point operation (CoMP). In-device Co-existence (IDC).
<b>Rel-10</b>	Frozen	2009-01-20	2011-06-08	LTE Advanced fulfilling IMT Advanced 4G requirements. Backwards compatible with release 8 (LTE). Multi-Cell HSDPA (4 carriers).
<b>Rel-9</b>	Frozen	2008-03-06	2010-03-25	SAES Enhancements, WiMAX and LTE/UMTS interop. Dual-Cell HSDPA with MIMO, Dual-Cell HSUPA. LTE HeNB.
<b>Rel-8</b>	Frozen	2006-01-23	2009-03-12	First LTE release. All-IP Network (SAE). New OFDMA, FDE, and MIMO based radio interface, not backwards compatible with previous CDMA interfaces. Dual-Cell HSDPA. UMTS HNB.

3GPP standards have evolved into their 5<sup>th</sup> Generation since reference [E1]. 5G standards are defined from 3GPP Release 15, onwards. The 3GPP Release 16 and Release 17 standards have been previously ratified. There are a set of three major capabilities that define 5G and are critical to future spaceflight requirements, as follows:

- Enhanced Mobile Broadband (eMBB): extremely high-speed communications data rate, in the 1-10 Gb/s class;
- Ultra-Reliable Low Latency Communications (URLCC): reaching extremely high-reliability wireless communications for mission-critical command and control and teleoperations, at wire line-class reliability, with latency sub-1 ms;
- Massive Machine-type Communications (mMTC): allowing for extremely dense clients, at densities in the 1 million devices per km<sup>2</sup> class.

5G achieves these capabilities by an evolution of the RF interface and an evolution of the network architecture used in 3GPP, compared to 4G LTE. The new radio technology, 5G NR, is based on a scalable OFDM solution, which can expand beyond the 15 kHz OFDM subcarrier spacing in factors of two, while also allowing for more subcarriers in a channel, and more channel aggregation, plus the optional ability to use OFDMA, instead of SC-FDMA, in the uplink. Additionally, allowed frequency bands are expanded above 3 GHz, and up into mmWave bands reaching up to 100 GHz. In the mmWave bands, it is expected that, for example, 500 MHz of bandwidth will be available in 28 GHz, 1 GHz at 38 GHz, and 2 GHz at 72 GHz. These high frequencies allow for beam-forming and massive MIMO in extremely compact antenna array and device sizes. However, starting at 600 MHz, 5G will also use low-band frequencies, and present 4G LTE bands will steadily be replaced by 5G bands, starting in 2020, as has happened in the transition from 2G and 3G to 4G LTE.

Initially, 5G NR systems are functioning with LTE EPC infrastructure, in what is called the Non-Standalone Architecture (NSA). NSA uses E-UTRAN NR Dual Connectivity (EN-DC), in which the control plane operates via LTE and the capacity plane can be 4G LTE and/or 5G NR. However, it is expected that 5G NR will quickly be interfaced to a Standalone Architecture (SA) in most commercial networks as early as late 2020 and during 2021. The 5G SA specification was approved in 3GPP Release 15 in June 2018 and will use pure 5G NR systems connected to 5G network cores (5GC). The key element of these cores is that they have a flexible virtual architecture in which different applications use different Virtual Network Functions (VNFs) that build up per-application architectures that are optimized to the QoS requirements of each application. This allows the removal of functions, when needed, from 4G LTE that generated large network latencies. This capability is implemented by considering the network to be comprised of a collection of systems in which each system is an effective virtual complete network architecture known as a Network Slice (NS). The NS for an application is created, configured, and managed through a complete lifecycle, including eventual destruction, by Orchestration. Combined with moving more computing services toward the client systems, known as Edge Computing, the sub-ms latencies can be fully used to build mission-critical networks.

### **C3.3 DEPLOYABLE MISSION-CRITICAL BROADBAND**

Since reference [E1], the US National Public Safety Telecommunications Council (NPSTC), in collaboration with the Canadian Defense Research and Development Canada's (DRDC) Centre for Security Science (CSS), has developed a set of public safety requirements for Broadband Deployable System (BBDS) technology, primarily LTE-based, in a two-year activity, as detailed in the April 2017 report in reference [E6]. Many of the requirements in that report are now already out of date due to the rapid evolution of LTE and 5G standards in the period over which it was developed. However, core architectural concepts and use cases still hold and can be considered to be overarching requirements for many spaceflight BBDS use cases.

### **C3.4 MISSION-CRITICAL SERVICES IN 3GPP**

3GPP standards are evolving to support Mission-Critical (MC) voice and data services directly. Corresponding standards have been developed for LTE through 3GPP Releases 13, 14, and 15, as described in reference [E13]. However, 5G is designed to support extremely critical services through new architectures, and LTE-based mission critical approaches based on QoS tagging and services will rapidly be superseded by software-defined dynamic architectures that implement and enforce mission critical service flows inside 3GPP networks, and to and from other non-3GPP networks.

### **C3.5 CORE EVOLUTION TO CONTROL USER PLANE SEPARATION**

The 3GPP EPC has undergone significant evolution since reference [E1]. The first of these changes is to formalize the split of Control Plane (CP) and User Plane (UP) traffic into fully independent planes via a division of core functions into CP and UP variants (reference [4]). This Control User Plane Separation (CUPS)-style core is shown in figure C-2. This split is described in reference [E7]; the Serving Gateway is replaced by UP, Serving Gateway-U, and CP, Serving Gateway-C, components, with a similar split for the PDN gateway into the PDN Gateway-U and PDN Gateway-C. Furthermore, the Traffic Detection Function (TDF), which was introduced since reference [E1], in Release 11 of the 3GPP standards, is also split into TDF-U and TDF-C. The job of the TDF and corresponding split variants are to support policy enforcement based on Layer 7 (Application) recognition and resulting flow control QoS parameters (see reference [9]). The corresponding reference point interfaces are either terminated at the appropriate component (UP or CP) or are split into the corresponding two reference point interfaces.

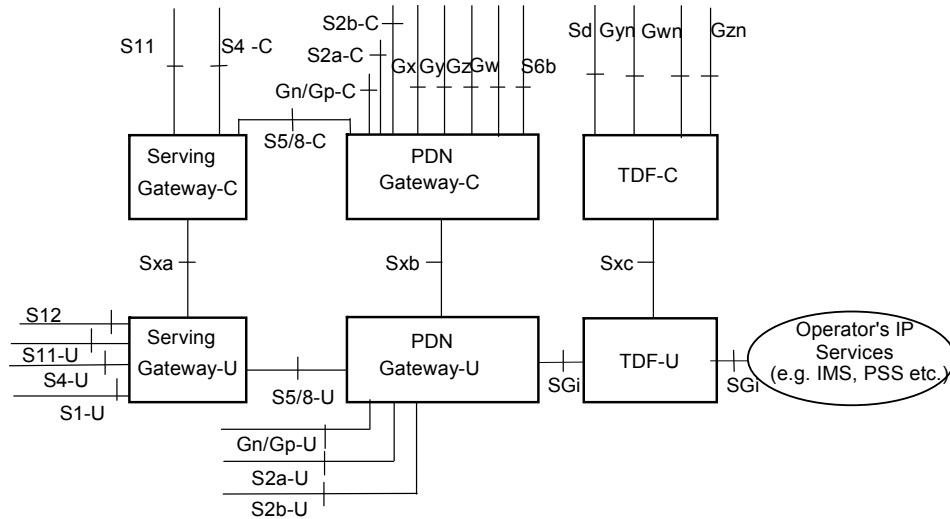

**Figure C-2: 3GPP Control User Plane Split<sup>1</sup>**

New reference point interfaces, Sxa, Sxb, Sxc, now run between the corresponding new UP or CP components of the original pre-CUPS' EPC. The form of this split allows for EPC implementations to use CUPS on a per-function basis, splitting or not splitting as desired, for compatibility and easy migration. Thus the Sx interfaces are not exposed outside each original EPC function and can implement improved protocols. In particular, 3GPP desired to allow for the move toward post-IP protocols and to avoid protocols such as SCTP and DIAMETER which has previously resulted in problematic LTE implementations with low scalability and high latency. The new protocol is the Packet Forwarding Control Protocol (PFCP). PFCP, which supports reliable message delivery, is transported via UDP/IP and not SCTP (see reference [6]). CUPS and PFCP represent a move toward fully independent control/signaling and user traffic paths, which are needed in low-latency/high-performance mission-critical networking, which is the primary aim of 5G. CUPS is particularly important as networks increase in raw throughput and UP transport QoS requirements dominate over, but are no more important than, CP transport QoS requirements. A full split such as CUPS allows for completely independent network transport hardware and hardware locations to be used for UP and CP traffic and functions.

The CUPS structure and the S8 roaming interface is critical for interface between an EPC and a 5GC and provides the evolution path between an LTE network and a 5G network. Under GSMA NG.113 (reference [3]), the link from the EPC to the 5GC is implemented by having a subset of the 5GC functions optionally implement corresponding EPC interfaces and equivalent functions. The interfaces are S6a, and the CUPS architecture is S8-C and S8-U. S6a operates between the EPC HSS and an HSS function implemented in the 5GC Unified Data Management (UDM) function. S8-C operates between the EPC S-GW (SGW-C) and a

<sup>1</sup> From reference [4], figure 4.2.1-1. Used with permission: "© 2020. 3GPP™ deliverables and material are the property of ARIB, ATIS, CCSA, ETSI, TSDSI, TTA and TTC who jointly own the copyright in them. They are subject to further modifications and are therefore provided to you "as is" for information purposes only. Further use is strictly prohibited."

PGW-C function implemented in a 5GC Session Management Function (SMF). S8-U operates between the EPC S-GW (SGW-U) and a PGW-U implemented in a 5GC User-Plane Function (UPF). Therefore an LTE network infrastructure that does not implement CUPS and S8 cannot connect with a 5G network infrastructure.

### **C3.6 PROXIMITY SERVICES IMPLEMENTATION**

At present, there has been no commercially available implementation of the ProSe sidelink direct-mode (infrastructure-free) communications architectures described in reference [E1] for smartphone-type UEs. However, 3GPP has been developing new standards for Vehicle-to-Vehicle (V2V) and Vehicle-to-Everything (V2X) communications, which has been derived from ProSe and its PC5 sidelink interface. The improvements, called Enhancement of 3GPP Support for V2X Services (eV2X), allow for operation at 500 km/h relative motion at 5.9 GHz, the frequency band reserved for Intelligent Transport System (ITS) communication networks. The new standard was completed for 3GPP Release 14 (see reference [E8]). The eV2X standard leads to an approach to cellular V2X (C-V2X) that is implemented via significantly more advanced and modern wireless networking technologies compared to an older 2012 IEEE standard, IEEE 802.11p, which was based on a reduced-performance version of 802.11a (see references [E9] and [E10]). Chipsets for the latest 3GPP Release 14 version of eV2X/C-V2X are now in production, and the standard is supported by all major automobile vendors.

### **C3.7 CHANNEL AGGREGATION**

Carrier Aggregation (CA), the ability to combine multiple (up to 20 MHz each) channels, each known as a Component Carrier (CC), into one effective channel, became standardized as of 3GPP Release 10, known as LTE Advanced (LTE-A). The combined bandwidth is called the Bandwidth Combination Set (BCS). The 3GPP documents provide explicit BCS configurations, in a constantly growing list across new bands and channels. A BCS configuration may include channels across many bands (inter-band) and/or across the same band (intra-band). As of 3GPP Release 15.3, internationally regulated BCS configurations exist up to 140 MHz aggregated bandwidth (100 MHz downlink and 40 MHz uplink) with 5-carrier aggregation. Massive CA became standardized in LTE Advanced (LTE-A) Pro, 3GPP Release 13 onwards, with corresponding modifications to control signaling to allow for efficient use of many CCs, as described in reference [E11]. LTE-A Pro in 3GPP Release 13 allows for up to 32 downlink CCs in a BCS, for a maximum downlink bandwidth of 640 MHz and performance of 3 Gb/s. 3GPP Release 13 also allows for up to two CCs on the uplink, for a maximum uplink performance of 150 Mb/s. However, 3GPP and ITU must define and allow corresponding BCS configurations to use the full expansion capability of LTE-A Pro.

An important component of CA is that each CC is considered to be a different cell, with control on only one cell/CC, called the Primary Serving Cell (PSC). The extra, purely user-plane, CCs are called Secondary Serving Cells (SSCs). The PSC and SSC CCs may be served off the same cell tower, or different ones. Because of the wide range of frequencies

across a given BCS, coverage in each CC will be different, even off the same cell tower, and certainly off different cell towers. Thus it is important to provide contiguous spatial coverage via PSC CCs, allowing for dynamic change in BCS as UEs transit across the entire network coverage area.

### **C3.8 LTE OPERATION IN NON-LICENSED BANDS**

3GPP standards evolution now supports the use of certified non-licensed devices and their associated spectrum for use in 3GPP applications. The latest version of this is the License Assisted Access (LAA) set of standards. LAA uses LTE control information in licensed spectrum bands, with extra user plane allowed to operate non-licensed device modules within their associated spectrum. This is enabled by using CA, with the PSC and potentially additional SSCs, in standard licensed bands and extra SSCs using unprotected spectrum in the 5.8 GHz band, designated as Band 46 in 3GPP Release 14 (reference [7]) with corresponding BCS configurations available to support LAA operation. The actual band used depends on the available bands in a given regulatory region, and would be one of 5.17 to 5.33, 5.49 to 5.725, or 5.725 to 5.835 GHz. These sub-bands are further divided into standard IEEE 802.11-defined 20 MHz channels. Some approved BCS configurations already allow up to three 20 MHz Band 46 channels to be bonded to specific licensed CCs. LAA was defined in 3GPP Release 13 and uses LAA on downlink CA only. 3GPP Release 14 defined extended LAA (eLAA), which also allows LAA on uplink CA.

As IEEE 802.11 can also operate in Band 46, it is critical for LTE applications to coexist without interfering. Therefore 3GPP, in Release 13, studied the use of Listen-Before-Talk (LBT) in LAA (reference [8]) to ensure that LTE systems only transmit on Band 46 during gaps in IEEE 802.11 traffic in the same channel. LBT became a component of eLAA in 3GPP Release 14. LAA/eLAA is also restricted to a 1 ms scheduling period, which generates up to a 4 ms one-way latency. This can significantly limit LAA/eLAA performance in shared user environments because of resulting long latencies for the LBT process to allow transmissions. Products have been commercially available to use LAA since 2017, with increasing network availability.

In the US, the Citizens Broadband Radio Service (CBRS), 3.550 to 3.700 GHz, band is presently being considered for LTE operations utilizing certified non-licensed devices, based on a variant of eLAA. Instead of using LBT, a Spectrum Access System (SAS) is used for control of LTE device access to the band. SAS is an emerging approach to CBRS use, in which band access is controlled by network-accessed infrastructure that brokers between user devices requiring RF spectrum. The CBRS Alliance (reference [E12]) manages specifications in this area.

### **C3.9 LATENCY**

Evolution of 3GPP standards has allowed LTE latency to move from 10 ms in LTE-A to 2 ms in LTE-A Pro. This is achieved by improving scheduling and access to uplink resources by pre-allocation and asynchronous acknowledgement, and by decreasing the Transmission Time

Interval (TTI). TTI is the frame length in LTE and is usually 1 ms, corresponding to 14 symbols. 3GPP R14 and R15 allow for optional shorter frames, by the use of a short TTI (sTTI) of 0.5 ms (7 symbols), 0.27 ms (4 symbols), and 0.14 ms (2 symbols). As the HARQ process can take seven frames in LTE-A Pro, the smallest sTTI option reduces the HARQ, and hence round-trip time (RTT) latency, down to 1 ms. This allows a wide range of time-critical applications of LTE-based communications links, including the C-V2X application set.

### **C3.10 CELLULAR INTERNET-OF-THINGS**

The IoT is rapidly growing and is often considered the primary driver of all levels of communications technology over the next decade. There are presently three approaches to cellular IoT, only one of which is based on LTE technology, but all three approaches have a defined evolution path in the 3GPP process. IoT must support a high device density with a potentially extremely high aggregate data rate over potentially millions of devices in a network, even though each device may have low to moderate per-device data communication rate requirements. Therefore 3GPP standards are evolving to support many Gb/s of total IoT mission-critical capacity per base station.

The Narrowband IoT standard, NB-IoT, is described by the LTE CAT-NB1 and CAT-M2 device categories and was introduced in 3GPP Release 13. NB-IoT is designed to work within LTE infrastructure but is not based on LTE modulation techniques. Instead, it uses DSSS, and not OFDM, to allow for extreme battery efficiency. Because of the simple modulation, none of the mobility support of LTE is available. Furthermore, neither is the motion (Doppler effect) tolerance or extreme multipath resistance of OFDM available. The result is that NB-IoT is only suitable for low-rate static sensor deployment. The use of DSSS means that special NB-IoT base stations are required. NB-IoT supports 164 dB in signal fade (minimum coupling loss) when operated at rates up to 50 kb/s.

LTE Machine-type Communications (eMTC/LTE-M/LTE-MTC) is an LTE-based cellular IoT reduced standard and provides higher data rates than NB-IoT. Battery life is less than NB-IoT, but significantly greater than full LTE. LTE-M devices (LTE CAT-M1) operate off a full LTE infrastructure, with eNodeBs that have appropriate software. The standard was introduced in 3GPP Release 12 and improved in later 3GPP Releases. LTE-M supports 155.7 dB in fade margin when operated at data rates up to 1 Mb/s.

A final standard, starting in 3GPP Release 13, is Extended Coverage GSM for IoT, EC-GSM-IoT, which is based on 2G E-GPRS/EDGE, is presently not in adoption, but allows for extreme range, which is also enabled via an available high transmit power level mode class. EC-GSM-IoT will support up to 164 dB fade when operated at data rates up to 240 kb/s.

All three approaches allow for devices to go into an idle mode, or fully shut down and wake up for scheduled transmissions, via Power Saving Mode (PSM) and extended discontinuous repetition cycle (eDRX).

### **C3.11 USER EQUIPMENT SECURITY EVOLUTION**

To allow the ability to support many more devices on future 3GPP networks, the USIM application housed in the UICC physical card installed in previous LTE UE devices by subscribers is being supplemented by one in an embedded UICC, the eUICC in new standards and devices. A corresponding eSIM standard is specified by the GSMA SGP.21 and SGP.22 Remote SIM Provisioning (RSP) standards. eSIMs can be provisioned via many programmatic methods from a standardized Subscription Manager Data Preparation+ (SM-DP+) server instead of via the physical swapping of a USIM. For UEs to be able to operate across more than one RAN in any configuration except for MOCN, both USIMs and eSIMs need to host information to join a local RAN with a different PLMN ID from the home network, called the Home Public Mobile Network (HPMN), and corresponding EPC or 5GC, of the USIM/eSIM. Both formats can support the concept of the list of Equivalent Home PLMN (EHPLMN) IDs to inform the UE that connectivity to the home PLMN is possible from another, Visited PMN (VPMN), with a different PLMN ID. USIMs can also be swapped out to allow for access to different network, and some UEs can support more than one physical USIM/UICC slot. The eSIM allows for multiple network identities to be hosted on the same device, up to the programming limits of the device, and for provisioning of new networks without the need to swap a physical UICC. Thus eSIM capability in future space systems requiring 3GPP-based authentication, including Wi-Fi Alliance Wi-Fi Certified Passpoint USIM/eSIM-based access to 3GPP network cores, will be important for forward compatibility with evolving standards.

Using physical UICCs, and potentially with future eUICCs, one very simple comingled form of inter-agency interoperability is possible by simply swapping the USIM and/or eSIM installed in the device for the one for a different agency's network. Multi-SIM devices can support multiple networks. This does not provide for inter-network interoperability but does allow for client nodes to be deployed on different established networks.

### **C3.12 NETWORK SERVICES EVOLUTION**

During LTE evolution, IP Multimedia Service (IMS) capability was added as an adjunct to the main EPC infrastructure to initially provide voice services and has been augmented to support a range of multi-media and mission-critical messaging and other data services, including imaging and video. IMS is an extensible framework that can allow connection to a wide range of IP-based services that are negotiated for Session Initiation Protocol (SIP) via a Call Session Control Function (CSCF). A CSCF communicates with the EPC via SGi to the EPC P-GW/PGW-U for UP and via the Rx interface to a PCRF communicating CP information via Gx to the P-GW/PGW-C for QoS information, including for mission-critical voice and video communications. Rx can also be used by other non-IMS external network services that require dynamic QoS requests throughout the LTE network to support corresponding service requests from a UE. Therefore it may be desirable for future LTE spacecraft networks to support a PCRF and the Gx and Rx interfaces. However, if evolution toward a 5G network is rapid in spaceflight applications, corresponding 5GC CP functions may supersede the need for these EPC functions and interfaces.

NOTE – This CCSDS Recommended Standard does not provide a recommendation concerning IP Multimedia Service (IMS).

ANNEX D

QCI – QOS CLASS IDENTIFIER OVERVIEW

(INFORMATIVE)

D1 SPACE COMMUNICATION QCI DEFINITION TABLE

The following table D-1 provides the QoS Class Identifier (QCI) Definitions for anticipated *common application data flows in the space domain*.

Table D-1: QoS Class Identifier Definitions for the Space Domain

QCI	Bearer Type	Priority	Packet Delay	Packet Loss	Space Communications Domain Example
1	GBR	2	100 ms	10 <sup>-2</sup>	Crew conversational voice
2		4	150 ms	10 <sup>-3</sup>	Crew conversational video (live streaming)
3		3	50 ms	10 <sup>-3</sup>	Telerobotics
4		5	300 ms	10 <sup>-6</sup>	Non-conversational video (buffered streaming); science data
65	GBR	0.7	75 ms	10 <sup>-2</sup>	Mission Critical user plane Push To Talk voice (e.g., MCPTT)
66	GBR	2	100 ms	10 <sup>-2</sup>	Non-Mission-Critical user plane Push To Talk voice
75	GBR	2.5	50 ms	10 <sup>-2</sup>	V2X messages
5	Non-GBR	1	100 ms	10 <sup>-6</sup>	IMS Signaling
6		6	300 ms		Video (buffered streaming) TCP-based (e.g., science data, www, e-mail, chat, ftp, p2p file sharing, progressive video, etc.)
7		7	100 ms	10 <sup>-3</sup>	Voice, Video (live streaming), Telerobotics
8		8	300 ms	10 <sup>-6</sup>	Vehicle-to-surface data and video (buffered streaming)
9		9			
69	Non-GBR	0.5	60 ms	10 <sup>-6</sup>	Mission Critical delay sensitive signaling (e.g., MC-PTT signaling)
70	Non-GBR	5.5	200 ms	10 <sup>-6</sup>	Mission Critical Data (e.g., example services are the same as QCI 6/8/9)
79	Non-GBR	6.5	50 ms	10 <sup>-2</sup>	V2X messages
80	Non-GBR	6.8	10 ms	10 <sup>-6</sup>	Low latency eMBB applications (TCP/UDP-based); Augmented Reality
82	GBR	1.9	10 ms	10 <sup>-4</sup>	Discrete Automation (small packets)
83	GBR	2.2	10 ms	10 <sup>-4</sup>	Discrete Automation (big packets)
84	GBR	2.4	30 ms	10 <sup>-5</sup>	Intelligent Transport Systems
85	GBR	2.1	5 ms	10 <sup>-5</sup>	Electricity Distribution - high voltage

Every QCI (GBR and Non-GBR) is associated with a Priority level. Priority level 0.5 is the highest Priority level. If congestion is encountered, the lowest Priority level traffic would be the first to be discarded.

QCI-65, QCI-66, QCI-69 and QCI-70 were introduced in 3GPP TS 23.203 Rel-12.

QCI-75 and QCI-79 were introduced in 3GPP TS 23.203 Rel-14.

(See annex subsection D2 for a detailed overview of standardized QCI characteristics.)

## D2 STANDARDIZED QCI CHARACTERISTICS

The QCI (reference [9]) is a scalar that is used as a reference to access node-specific parameters that control bearer-level packet forwarding treatment (e.g., scheduling weights, admission thresholds, queue management thresholds, Data Link Layer protocol configuration), and that have been pre-configured by the operator owning the access node.

The standardized characteristics are not signaled on any interface. *They should be understood as guidelines for the pre-configuration of node-specific parameters for each QCI.*

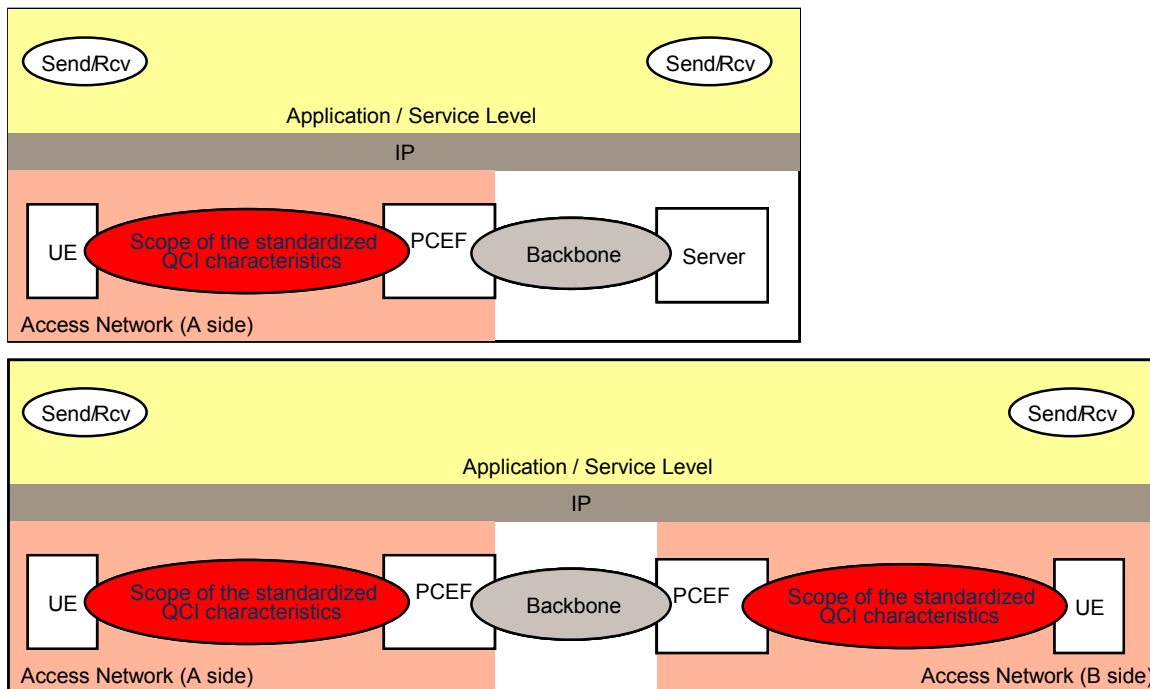

**Figure D-1: Scope of Standardized QCI Model for Client/server and Peer Communication<sup>1</sup>**

Each Service Data Flow (SDF) is associated with one and only one QCI.

<sup>1</sup> From reference [9], figure 6.1.7-1. Used with permission: "© 2019. 3GPP™ deliverables and material are the property of ARIB, ATIS, CCSA, ETSI, TSDSI, TTA and TTC who jointly own the copyright in them. They are subject to further modifications and are therefore provided to you "as is" for information purposes only."

For the same IP-Connectivity Access network session, multiple SDFs with the same QCI and Allocation and Retention Priority (ARP) can be treated as a single traffic aggregate that is referred to as an SDF aggregate. An SDF is a special case of an SDF aggregate.

The service level (i.e., per service data flow, SDF, or per SDF aggregate) QoS parameters are QCI, ARP, GBR, and MBR. The default QoS consists of a QCI and MBR.

- QCI: QCI is a scalar that is used as a reference to access node-specific parameters that control bearer level packet forwarding treatment.
- ARP: Allocation and Retention Priority characteristics.
- GBR: An IP Connectivity Access Network (IP-CAN) bearer with reserved (guaranteed) bitrate resources.
- MBR: Maximum bitrate.

The QoS parameter ARP contains information about the priority level, the pre-emption capability, and the pre-emption vulnerability. The priority level defines the relative importance of a resource request. This allows deciding whether a bearer establishment or modification request can be accepted or needs to be rejected in case of resource limitations (typically used for admission control of GBR traffic). It can also be used to decide which existing bearers to pre-empt during resource limitations. The ARP priority scheme is completely separate from the packet prioritization priority scheme upon which the QCI parameter is based.

The range of the ARP priority level is 1 to 15 with 1 as the highest level of priority. The pre-emption capability information defines whether a service data flow can get resources that were already assigned to another service data flow with a lower priority level. The pre-emption vulnerability information defines whether a service data flow can lose the resources assigned to it in order to admit a service data flow with higher priority level. The pre-emption capability and the pre-emption vulnerability can be either set to ‘yes’ or ‘no’.

The ARP priority levels 1-8 should only be assigned to resources for services that are authorized to receive prioritized treatment within an operator domain (i.e., that are authorized by the serving network). The ARP priority levels 9-15 may be assigned to resources that are authorized by the home network and thus applicable when a UE is roaming.

NOTE – This ensures that future releases may use ARP priority level 1-8 to indicate, for example, emergency and other priority services within an operator domain in a backward compatible manner. This does not prevent the use of ARP priority level 1-8 in roaming situation in case appropriate roaming agreements exist that ensure a compatible use of these priority levels.

The one-to-one mapping of standardized QCI values to standardized characteristics is summarized in table D-2.

## **Standardized QCI Characteristics**

Reference [9] specifies standardized characteristics associated with standardized QCI values.

The characteristics describe the packet forwarding treatment that an SDF aggregate receives edge-to-edge between the UE and the PCEF (based upon figure 6.1.7-1 in reference [9]) in terms of the following performance characteristics:

- GBR/Non-GBR – defines whether or not the bandwidth assignment to the associated bearer is enforced;
- Scheduling Priority – for all packets (GBR and Non-GBR) defines the relative importance of the packet for transmission over-the-air;
- Packet Loss Rate – for the associated bearer, this is the maximum tolerable packet loss rate with or without the presence of congestion;
- Packet Delay Budget – for the associated bearer, this is the maximum tolerable transmission delay for a packet.

The Resource Type determines if dedicated network resources related to a service or bearer level Guaranteed Bit Rate (GBR) value are permanently allocated (e.g., by an admission control function in a radio base station). GBR SDF aggregates are therefore typically authorized ‘on demand’, which requires dynamic policy and charging control. A Non GBR SDF aggregate may be pre-authorized through static policy and charging control.

The Packet Delay Budget (PDB) defines an upper bound for the time that a packet may be delayed between the UE and the PCEF. For a certain QCI the value of the PDB is the same in uplink and downlink. The purpose of the PDB is to support the configuration of scheduling and Data Link Layer functions (e.g., the setting of scheduling priority weights and HARQ target operating points). The PDB shall be interpreted as a maximum delay with a confidence level of 98 percent.

NOTE – The PDB denotes a ‘soft upper bound’ in the sense that an ‘expired’ packet, for example, a Data Link Layer SDU that has exceeded the PDB, does not need to be discarded (e.g., by RLC in E-UTRAN). The discarding (dropping) of packets is expected to be controlled by a queue management function, for example, based on pre-configured dropping thresholds.

The support for SRVCC requires QCI=1 only be used for IMS speech sessions in accordance with TS 23.216 (reference [32]).

**Table D-2: Standardized QCI Characteristics<sup>1</sup>**

QCI	Resource Type	Priority Level	Packet Delay Budget	Packet Error Loss Rate (note 2)	Example Services
1 (note 3)		2	100 ms (note 1, note 11)	10-2	Conversational Voice
2 (note 3)	GBR	4	150 ms (note 1, note 11)	10-3	Conversational Video (Live Streaming)
3 (note 3)		3	50 ms (note 1, note 11)	10-3	Real Time Gaming
4 (note 3)		5	300 ms (note 1, note 11)	10-6	Non-Conversational Video (Buffered Streaming)
65 (note 3, note 9)		0.7	75 ms (note 7, note 8)	10-2	Mission Critical user plane Push To Talk voice (e.g., MCPTT)
66 (note 3)		2	100 ms (note 1, note 10)	10-2	Non-Mission-Critical user plane Push To Talk voice
5 (note 3)		1	100 ms (note 1, note 10)	10-6	IMS Signaling
6 (note 4)		6	300 ms (note 1, note 10)	10-6	Video (Buffered Streaming) TCP-based (e.g., www, e-mail, chat, ftp, p2p file sharing, progressive video, etc.)
7 (note 3)	Non-GBR	7	100 ms (note 1, note 10)	10-3	Voice, Video (Live Streaming) Interactive Gaming
8 (note 5)		8	300 ms (note 1)	10-6	Video (Buffered Streaming) TCP-based (e.g., www, e-mail, chat, ftp, p2p file)
9 (note 6)		9			Sharing, progressive video, etc.)
69 (note 3, note 9)		0.5	60 ms (note 7, note 8)	10-6	Mission Critical delay sensitive signaling (e.g., MC-PTT signaling)
70 (note 4)		5.5	200 ms (note 7, note 10)	10-6	Mission Critical Data (e.g., example services are the same as QCI 6/8/9)

<sup>1</sup> From reference [9], table 6.1.7-A. Used with permission: "© 2019. 3GPP™ deliverables and material are the property of ARIB, ATIS, CCSA, ETSI, TSDSI, TTA and TTC who jointly own the copyright in them. They are subject to further modifications and are therefore provided to you "as is" for information purposes only."

NOTES

- 1 A delay of 20 ms for the delay between a PCEF and a radio base station should be subtracted from a given PDB to derive the packet delay budget that applies to the radio interface. This delay is the average between the case in which the PCEF is located 'close' to the radio base station (roughly 10 ms) and the case in which the PCEF is located 'far' from the radio base station, for example, in the case of roaming with home routed traffic (the one-way packet delay between Europe and the US west coast is roughly 50 ms). The average takes into account that roaming is a less typical scenario. It is expected that subtracting this average delay of 20 ms from a given PDB will lead to desired end-to-end performance in most typical cases. Also, it should be noted that the PDB defines an upper bound. Actual packet delays, in particular, for GBR traffic, should typically be lower than the PDB specified for a QCI as long as the UE has sufficient radio channel quality.
- 2 The rate of non-congestion-related packet losses that may occur between a radio base station and a PCEF should be regarded to be negligible. A PELR value specified for a standardized QCI therefore applies completely to the radio interface between a UE and radio base station.
- 3 This QCI is typically associated with an operator-controlled service, that is, a service in which the SDF aggregate's uplink/downlink packet filters are known at the point in time when the SDF aggregate is authorized. In the case of E-UTRAN, this is the point in time when a corresponding dedicated EPS bearer is established/modified.
- 4 If the network supports Multimedia Priority Services (MPS), then this QCI could be used for the prioritization of non-real-time data (i.e., most typically TCP-based services/applications) of MPS subscribers.
- 5 This QCI could be used for a dedicated 'premium bearer' (e.g., associated with premium content) for any subscriber/subscriber group. Also in this case, the SDF aggregate's uplink/downlink packet filters are known at the point in time when the SDF aggregate is authorized. Alternatively, this QCI could be used for the default bearer of a UE/PDN for 'premium subscribers'.
- 6 This QCI is typically used for the default bearer of a UE/PDN for non-privileged subscribers. It should be noted that AMBR can be used as a 'tool' to provide subscriber differentiation between subscriber groups connected to the same PDN with the same QCI on the default bearer.
- 7 For Mission Critical services, it may be assumed that the PCEF is located 'close' to the radio base station (roughly 10 ms) and is not normally used in a long distance, home routed roaming situation. Hence delay of 10 ms for the delay between a PCEF and a radio base station should be subtracted from this PDB to derive the packet delay budget that applies to the radio interface.
- 8 In both RRC Idle and RRC Connected mode, the PDB requirement for these QCIs can be relaxed (but not to a value greater than 320 ms) for the first packet(s) in a downlink data or signaling burst in order to permit reasonable battery saving (DRX) techniques.
- 9 It is expected that QCI-65 and QCI-69 are used together to provide Mission Critical Push to Talk service (e.g., QCI-5 is not used for signaling for the bearer that utilizes QCI-65 as user plane bearer). It is expected that the amount of traffic per UE will be similar or less compared to the IMS signaling.
- 10 In both RRC Idle and RRC Connected mode, the PDB requirement for these QCIs can be relaxed for the first packet(s) in a downlink data or signaling burst in order to permit battery saving (DRX) techniques.
- 11 In RRC Idle mode, the PDB requirement for these QCIs can be relaxed for the first packet(s) in a downlink data or signaling burst in order to permit battery saving (DRX) techniques.

## ANNEX E

### INFORMATIVE REFERENCES

#### (INFORMATIVE)

- [E1] *Wireless Network Communications Overview for Space Mission Operations*. Issue 3. Report Concerning Space Data System Standards (Green Book), CCSDS 880.0-G-3. Washington, D.C.: CCSDS, May 2017.
- [E2] “IEEE 802.11ay: 1st Real Standard for Broadband Wireless Access (BWA) via mmWave.” June 15, 2018. IEEE ComSoc Technology Blog. <https://techblog.comsoc.org/2018/06/15/ieee-802-11ay-1st-real-standard-for-broadband-wireless-access-bwa-via-mmwave/>.
- [E3] “Qualcomm and Facebook to Bring High-Speed Internet Connectivity Over 60GHz to Urban Areas.” May 21, 2018. Qualcomm. <https://www.qualcomm.com/news/releases/2018/05/21/qualcomm-and-facebook-bring-high-speed-internet-connectivity-over-60ghz>.
- [E4] E. Khorov, et al. “A Tutorial on IEEE 802.11ax High Efficiency WLANs.” *IEEE Communications Surveys & Tutorials* 21, no. 1 (2019): 197–216.
- [E5] “IEEE P802.11 - Task Group AX - Group Information Update: Status of Project IEEE 802.11ax.” IEEE-SA - Working Group. [https://grouper.ieee.org/groups/802/11/Reports/tgax\\_update.htm](https://grouper.ieee.org/groups/802/11/Reports/tgax_update.htm).
- [E6] *Broadband Deployable Systems in the Nationwide Public Safety Broadband Network: A Report from the National Public Safety Telecommunications Council and the Defence Research and Development Canada’s Centre for Security Science*. Centennial, Colorado: NPSTC, April 2017.
- [E7] Peter Schmitt, Bruno Landais, and Frank Yong Yang. “Control and User Plane Separation of EPC Nodes (CUPS).” July 03, 2017. 3GPP. <https://www.3gpp.org/news-events/1882-cups>.
- [E8] Dino Flore. “Initial Cellular V2X Standard Completed.” September 26, 2016. 3GPP. [https://www.3gpp.org/news-events/3gpp-news/1798-v2x\\_r14](https://www.3gpp.org/news-events/3gpp-news/1798-v2x_r14).
- [E9] “OnQ Blog: Let’s set the record straight on C-V2X.” April 25, 2018. Qualcomm. <https://www.qualcomm.com/news/onq/2018/04/25/lets-set-record-straight-c-v2x>.
- [E10] Jovan Zagajac. “The C-V2X Proposition.” Presented at C-V2X Workshop & Demonstration for North American Transportation Planning and North American Road Operators (April 26, 2018, Washington, DC). <https://www.qualcomm.com/media/documents/files/5gaa-the-case-for-c-v2x.pdf>

- [E11] Ankit Bhamri, Kari Hooli, and Timo Lunttila. “Massive Carrier Aggregation in LTE-Advanced Pro: Impact on Uplink Control Information and Corresponding Enhancements.” *IEEE Communications Magazine* 54, no. 5 (May 2016): 92–97.
- [E12] CBRS Alliance. <https://www.cbrsalliance.org>.
- [E13] “Mission Critical Services in 3GPP.” June 20, 2017. 3GPP. [https://www.3gpp.org/NEWS-EVENTS/3GPP-NEWS/1875-MC\\_SERVICES](https://www.3gpp.org/NEWS-EVENTS/3GPP-NEWS/1875-MC_SERVICES).
- [E14] “Wi-Fi Direct.” Wi-Fi Alliance. <https://www.wi-fi.org/discover-wi-fi/wi-fi-direct>.
- [E15] LoRa Alliance®. <https://lora-alliance.org/>.
- [E16] *Proximity Wireless Network Communications Interoperability Test Report*. ITR 883x0b1-Y. Forthcoming.
- [E17] “Roadmap - IEEE Future Networks.” IEEE. <https://futurenetworks.ieee.org/roadmap>.
- [E18] “5G NR C-V2X Progress Report.” Presented at Meeting of Collaboration on ITS Communication Standards (8 March 2019, Geneva). [https://www.itu.int/en/ITU-T/extcoop/cits/Documents/Meeting-20190308-Geneva/14\\_5GAA-progress\\_report.pdf](https://www.itu.int/en/ITU-T/extcoop/cits/Documents/Meeting-20190308-Geneva/14_5GAA-progress_report.pdf)
- [E19] *ETSI Plugtests Report: 1st ETSI C-V2X Plugtests (2–6 December 2019, Malaga, Spain)*. V1.0.0. Sophia-Antipolis: ETSI, December 2019.
- [E20] “Official EEE 802.11 Working Group Project Timelines—2020-12-23.” LMSC, LAN/MAN Standards Committee (Project 802). [https://www.ieee802.org/11/Reports/802.11\\_Timelines.htm](https://www.ieee802.org/11/Reports/802.11_Timelines.htm). (31 December 2020)
- [E21] Youjia Chen, et al. “Dynamic Reuse of Unlicensed Spectrum: An Inter-Working of LTE and WiFi.” *IEEE Wireless Communications* 24, no. 5 (October 2017): 52–59.
- [E22] Massimiliano Maule, et al. “Delivering Fairness and QoS Guarantees for LTE/Wi-Fi Coexistence Under LAA Operation.” *IEEE Access* 6 (23 January 2018): 7359–7373.
- [E23] Dmitry Chizhik, et al. “Analytic Propagation Approximation over Variable Terrain and Comparison to Data.” In *2020 14th European Conference on Antennas and Propagation (EuCAP) (15–20 March 2020, Copenhagen, Denmark)*, 1–3. Piscataway, New Jersey: IEEE Conference Publications, 2020.
- [E24] Chatwin Lansdowne, et al. “Spacecraft Wireless System Performance Degradation Due to Impedance Mismatch in Cables and Connectors.” In *2019 IEEE Topical Workshop on Internet of Space (TWIOS) (20–23 January 2019, Orlando, Florida)*, 1–4. Piscataway, New Jersey: IEEE Conference Publications, 2019.
- [E25] “Lunar Surface Propagation Modeling and Effects on Communications.” In *26th International Communications Satellite Systems Conference (ICSSC) (10–12 June 2008, San Diego, CA)*. Reston, Virginia: AIAA, 2008.

## ANNEX F

### ABBREVIATIONS AND ACRONYMS

#### (INFORMATIVE)

<u>Term</u>	<u>Meaning</u>
3G	3 <sup>rd</sup> Generation cellular communications
3GPP	3rd Generation Partnership Project
4G	4 <sup>th</sup> Generation cellular communications
5G	5 <sup>th</sup> Generation cellular communications
5GC	5G Core
6G	6 <sup>th</sup> Generation cellular communications
AP	access point
APN	access point name
ARP	allocation and retention priority
AS	access stratum
BBDS	broadband deployable system
BBF	Broadband Forum
BCS	bandwidth combination set
BPSK	binary phase shift keying
CA	carrier aggregation
CBRS	Citizens Band Radio Service
CC	(1) component carrier; (2) county code
CCA	clear channel assessment
CCSDS	Consultative Committee for Space Data Systems
CDMA	code division multiple access
CDRDC	Canadian Defense Research and Development Centre
CoMP	coordinated multi-point
CORF	Committee On Radio Frequencies [US National Academies of Sciences, Engineering and Medicine]
COTS	commercial-off-the-shelf
CP	(1) control plane; (2) cyclic prefix
CRAF	Committee for Radio Astronomy Frequencies of the European Science Foundation
CSA	Canadian Space Agency
CSCF	call session control function
CSS	Centre for Security Science
CUPS	control user plane separation
D2D	device-to-device
dB	decibels
dBr	decibels relative to reference level
DRDC	Canadian Defense Research and Development Centre
DSS	dynamic spectrum sharing
DSSS	direct sequence spread spectrum

**CCSDS HISTORICAL DOCUMENT**  
RECOMMENDED STANDARD FOR WIRELESS PROXIMITY NETWORK COMMUNICATIONS

DTN	Delay-/Disruption-Tolerant Networking
EAP	Extensible Authentication Protocol
eDRX	extended discontinuous repetition cycle
EHPLMN	equivalent home PLMN
EHT	extremely high throughput
eLAA	enhanced licensed assisted access
eMBB	enhanced mobile broadband
eNB, eNodeB	evolved node base station [3GPP]
EN-DC	E-UTRAN NR dual connectivity
EPC	evolved packet core
ESA	European Space Agency
eSIM	embedded SIM
ETSI	European Telecommunications Standards Institute
eUICC	embedded universal integrated circuit card
E-UTRAN	Evolved-UMTS Terrestrial Radio Access Network
EVA	extra-vehicular activity
ExWC	Exploration Wireless Communications
FDD	frequency division duplex
FSF	frequency selective fading
GBR	guaranteed bitrate (bearer)
GI	guard interval
gNB	5G node base station [3GPP]
GSMA	Global System for Mobile Communications Association
GTP	GPRS Tunnelling Protocol-user data
GW	gateway
GWCN	gateway core networking
HARQ	hybrid automated repeat request
HetNet	heterogeneous networks
HO	handover
HPMN	home public mobile network
HSDPA	high speed data packet access
HSS	home subscriber server
HT	high throughput
IAU	International Astronomical Union
ICCID	integrated circuit card identifier
ICSI	IMS Communication Service Identifier
IEEE	Institute of Electrical and Electronics Engineers
IMS	IP multimedia system
IMSI	international mobile subscriber identifier
IMT	international mobile telecommunications
IoT	internet of things
IP	Internet Protocol
ISI	inter-symbol interference
ISM	industrial, scientific, and medical
ISS	International Space Station
ITS	intelligent transportation system

ITU	International Telecommunication Union
ITU-WP7D	ITU Working Party 7D [radio astronomy]
IUCAF	Scientific Committee on Frequency Allocations for Radio Astronomy and Space Science
LAA	licensed assisted access
LAA NR-U	licensed assisted access new radio unlicensed
LAN	local area network
LBT	listen before talk
LED	light emitting diode
LoRa	Long Range
LSA	licensed shared access
LTE	long-term evolution
LTE-A Pro	LTE Advanced Pro
LTE-A	LTE Advanced
MAC	media access control
MAN	metropolitan area network
MBSP	Multimedia Broadcast Supplement for Public Warning System
MBR	maximum bitrate (bearer)
MC	mission critical
MCC	mobile country code
MCPTT	mission critical push-to-talk
MCS	modulation and coding scheme
MII	major issuer identifier
MIMO	multiple-input, multiple-output
MISO	multiple-input, single-output
MME	mobile management entity
mMIMO	massive multiple-input, multiple-output
mMTC	massive machine-type communications
mmWave	millimeter wave [24 GHz and 100 GHz]
MNC	mobile network code
MOCN	multi-operator core network
MTC	machine-type communication
MU	multi-user
MU-MIMO	multi-user multiple-input, multiple-output
MVNO	Mobile Virtual Network Operator
NASA	National Space and Aeronautics Administration
NB-IoT	narrow band internet of things
NPSTC	National Public Safety Telecommunications Council
NR	new radio [5G]
NS	network slice
NSA	non-standalone architecture
NTN	non-terrestrial network
OFDM	orthogonal frequency division multiplexing
OFDMA	orthogonal frequency-division multiple access
OOB	out of band
OSI	Open Systems Interconnection

p2p	point-to-point
PCC	policy and charging control
PCEF	policy and charging enforcement function
PCF	policy control function
PCRF	policy and charging rules function
PDB	packet delay budget
PDCP	Packet Data Convergence Protocol
PDN	packet data network
PDU	protocol data unit
PFCP	Packet Forwarding Control Protocol
P-GW	packet data gateway
PHY	physical
PICS	protocol implementation conformance statement
PLMN	public land mobile network
PMN	private mobile network
ProSe	proximity services
PSC	primary serving cell
PSM	power savings mode
QAM	quadrature amplitude modulation
QCI	quality characterization index
QoE	quality of experience
QoS	quality of service
QPSK	quadrature phase-shift keying
RA	radio astronomy
RAFCAP	Radio Astronomy Frequency Committee in the Asia Pacific
RAN	radio access network
RF	radio frequency
RFM	radio frequency and modulation
RL	requirements list
RLC	radio link control
RR	radio regulation
RSP	remote SIM provisioning
RTT	round trip time
SA	standalone architecture
SAE	System Architecture Evolution
SANA	Space Assigned Numbers Authority
SAS	spectrum access system
SC-FDMA	single-carrier frequency division multiple access
SCTP	Stream Control Transmission Protocol
SDF	service data flow
SDU	service data unit
SD-WAN	software defined wide area networking
SFCG	Space Frequency Coordination Group
S-GW	serving gateway
SIM	subscriber identity module
SIMO	single-input, multiple-output

**CCSDS HISTORICAL DOCUMENT**  
RECOMMENDED STANDARD FOR WIRELESS PROXIMITY NETWORK COMMUNICATIONS

SIP	session initiation protocol
SLS	Space Link Services
SM-DP+	subscriber manager data preparation
SMF	session management function
SSC	secondary serving cell
SSID	service set identifier
sTTI	short transmission time interval
SWaP	space, weight and power
SZM	shielded zone of the moon
TBD	to be determined
TCP	Transmission Control Protocol
TDD	time division duplex
TDF	traffic detection function
TS	technical specification
TSN	time sensitive networking
TTI	transmission time interval
TWT	target wake time
UAV	unmanned aerial vehicle
UDM	unified data management
UDP	User Datagram Protocol
UE	user equipment
UHF	ultra-high frequency
UICC	universal integrated circuit card
UMTS	universal mobile telecommunications system
UNII	unlicensed national information infrastructure
UP	user plane
UPF	user plane function
URLCC	ultra-reliable low latency communications
USIM	UMTS identity module
USLP	Unified Space Data Link Protocol
V2V	vehicle-to-vehicle
V2X	vehicle-to-everything
VHF	very high frequency
VHT	very high throughput
VNF	virtual network function
VPMN	visited public mobile network
WFA	Wi-Fi Alliance
WG	Working Group
Wi-Fi	wireless fidelity
WLAN	wireless local area network
WPA	Wi-Fi Protected Access [WPA2, WPA3]
WPNIID	wireless proximity network ID

## ANNEX G

### TDD, FDD, AND LTE CONSIDERATIONS

#### (INFORMATIVE)

Transmission multiplexing for any radio technology is dependent upon spectrum availability. If only a single frequency band is available for combined uplink and downlink communications this necessitates a TDD scheme where a sender and receiver utilize the exact same spectrum in time multiplexed fashion. Frequency division duplexing (FDD) requires paired spectrum bands with a sufficient guard band to eliminate co-channel interference. Table G-1 summarizes engineering and deployment considerations for LTE TDD and FDD deployments.

**Table G-1: LTE, FDD, and TDD Considerations**

Parameter	LTE-TDD	LTE-FDD
<b>Paired Spectrum</b>	Does not require paired spectrum as both transmit and receive occur on the same RF channel.	Required paired spectrum with sufficient frequency separation to allow simultaneous transmission and reception.
<b>Channel reciprocity</b>	Channel propagation is the same in both directions, which enables transmit and receive to use one set of parameters.	Channel characteristics are different in the two directions as a result of the use of different frequencies on the uplink and downlink.
<b>UL/DL asymmetry</b>	Possible to dynamically change the uplink and downlink capacity ratio.	UL/DL capacity is determined by frequency allocation. It is not possible to dynamically change the uplink and downlink capacity ratio. Capacity is nominally allocated to be the same in either (UL/DL) direction.
<b>Guard period / guard band</b>	Guard period required to ensure uplink and downlink transmissions do not clash. Large guard period will limit capacity. Larger guard period normally required for greater distances to accommodate greater propagation times.	Guard band required to provide sufficient isolation between uplink and downlink channels. A large guard band does not impact capacity.
<b>Discontinuous transmission</b>	Discontinuous transmission is required to allow both uplink and downlink transmissions. This can degrade the performance of the RF power amplifier in the transmitter.	Continuous transmission is required.
<b>Cross slot interference</b>	Base stations must be synchronized with respect to the uplink and downlink transmission times. If neighboring base stations use different uplink and downlink assignments and share the same channel, then interference may occur between cells.	Not applicable.

## ANNEX H

### PROPOSED FUTURE STANDARDIZATION ACTIVITIES (INFORMATIVE)

**Table H-1: Roadmap for Future Standardization Activities**

Activity	Status	Start	End	Capabilities and Services
<b>CCSDS 883.0-B-1</b>	Open	2020-02-15	2020-12-31	<p>Topics include: IEEE 802.11 and 3GPP standards for space proximity wireless network communications.</p> <p>IEEE 802.11 (WFA):</p> <ul style="list-style-type: none"> <li>802.11n 2.4 GHz/5 GHz (Wi-Fi 4)</li> <li>802.11ac 5 GHz (Wi-Fi 5, wave 1 and wave 2)</li> <li>802.11ax 2.4 GHz, 5 GHz (Wi-Fi 6) 6 GHz (Wi-Fi 6E), 802.11be 2.4, 5, 6 GHz (Wi-Fi 7)</li> <li>802.11k-r-v Enterprise Roaming</li> </ul> <p>NOTE– IEEE 802.11n (Wi-Fi 4) products are recommended only for legacy system.</p> <p>3GPP</p> <ul style="list-style-type: none"> <li>LTE: SIM Interop</li> <li>LTE: Multi-RAN</li> <li>LTE: Multi Operator Core Network</li> <li>LTE: APN Routing</li> </ul> <p>Focus is on true 3GPP Roaming for ICSIs, Gateway GWCN CUPS</p> <p>Focus on 802.11 updated standards and hardware</p> <ul style="list-style-type: none"> <li>Wi-Fi 6E 6 GHz</li> <li>802.11ay 60 GHz</li> <li>802.11ah 900 MHz</li> </ul> <p>Focus on 3GPP LTE/5G Rel-16, Rel-17 updates</p> <ul style="list-style-type: none"> <li>5G RAN and Core interoperability</li> <li>C-V2X, D2D</li> <li>Network Slicing</li> <li>IoT</li> </ul> <p>Satellite LTE/5G (backhaul, RAN)</p> <p>Advanced spectrum sharing</p> <ul style="list-style-type: none"> <li>Dynamic Spectrum Sharing (DSS)</li> <li>Licensed Assist Access (LAA)</li> <li>Licensed Shared Access (LSA)</li> </ul>

The roadmap includes an intersessional SOIS/Wireless-SLS/RFM meeting during every CCSDS meeting, for coordination about frequency band and modulations sets issues.