

CCSDS Historical Document

This document's Historical status indicates that it is no longer current. It has either been replaced by a newer issue or withdrawn because it was deemed obsolete. Current CCSDS publications are maintained at the following location:

<http://public.ccsds.org/publications/>

Recommendation for Space Data System Standards

OPTICAL COMMUNICATIONS CODING AND SYNCHRONIZATION

RECOMMENDED STANDARD

CCSDS 142.0-B-1

BLUE BOOK
August 2019

Recommendation for Space Data System Standards

**OPTICAL
COMMUNICATIONS
CODING AND
SYNCHRONIZATION**

RECOMMENDED STANDARD

CCSDS 142.0-B-1

BLUE BOOK
August 2019

AUTHORITY

Issue:	Recommended Standard, Issue 1
Date:	August 2019
Location:	Washington, DC, USA

This document has been approved for publication by the Management Council of the Consultative Committee for Space Data Systems (CCSDS) and represents the consensus technical agreement of the participating CCSDS Member Agencies. The procedure for review and authorization of CCSDS documents is detailed in *Organization and Processes for the Consultative Committee for Space Data Systems* (CCSDS A02.1-Y-4), and the record of Agency participation in the authorization of this document can be obtained from the CCSDS Secretariat at the email address below.

This document is published and maintained by:

CCSDS Secretariat
National Aeronautics and Space Administration
Washington, DC, USA
Email: secretariat@mailman.ccsds.org

STATEMENT OF INTENT

The Consultative Committee for Space Data Systems (CCSDS) is an organization officially established by the management of its members. The Committee meets periodically to address data systems problems that are common to all participants, and to formulate sound technical solutions to these problems. Inasmuch as participation in the CCSDS is completely voluntary, the results of Committee actions are termed **Recommended Standards** and are not considered binding on any Agency.

This **Recommended Standard** is issued by, and represents the consensus of, the CCSDS members. Endorsement of this **Recommendation** is entirely voluntary. Endorsement, however, indicates the following understandings:

- o Whenever a member establishes a CCSDS-related **standard**, this **standard** will be in accord with the relevant **Recommended Standard**. Establishing such a **standard** does not preclude other provisions which a member may develop.
- o Whenever a member establishes a CCSDS-related **standard**, that member will provide other CCSDS members with the following information:
 - The **standard** itself.
 - The anticipated date of initial operational capability.
 - The anticipated duration of operational service.
- o Specific service arrangements shall be made via memoranda of agreement. Neither this **Recommended Standard** nor any ensuing **standard** is a substitute for a memorandum of agreement.

No later than five years from its date of issuance, this **Recommended Standard** will be reviewed by the CCSDS to determine whether it should: (1) remain in effect without change; (2) be changed to reflect the impact of new technologies, new requirements, or new directions; or (3) be retired or canceled.

In those instances when a new version of a **Recommended Standard** is issued, existing CCSDS-related member standards and implementations are not negated or deemed to be non-CCSDS compatible. It is the responsibility of each member to determine when such standards or implementations are to be modified. Each member is, however, strongly encouraged to direct planning for its new standards and implementations towards the later version of the Recommended Standard.

FOREWORD

This document is a CCSDS Recommended Standard for the channel coding and synchronization of signals to be used in free space optical communications systems of space missions. It was contributed to CCSDS by NASA. The channel coding and synchronization concepts described herein are intended for missions that are cross-supported between Agencies of the CCSDS.

Attention is drawn to the possibility that some of the elements of this document may be the subject of patent rights. CCSDS has processes for identifying patent issues and for securing from the patent holder agreement that all licensing policies are reasonable and non-discriminatory. However, CCSDS does not have a patent law staff, and CCSDS shall not be held responsible for identifying any or all such patent rights.

Through the process of normal evolution, it is expected that expansion, deletion, or modification of this document may occur. This Recommended Standard is therefore subject to CCSDS document management and change control procedures, which are defined in *Organization and Processes for the Consultative Committee for Space Data Systems* (CCSDS A02.1-Y-4). Current versions of CCSDS documents are maintained at the CCSDS Web site:

<http://www.ccsds.org/>

Questions relating to the contents or status of this document should be sent to the CCSDS Secretariat at the email address indicated on page i.

CCSDS RECOMMENDED STANDARD FOR
OPTICAL COMMUNICATIONS CODING AND SYNCHRONIZATION

At time of publication, the active Member and Observer Agencies of the CCSDS were:

Member Agencies

- Agenzia Spaziale Italiana (ASI)/Italy.
- Canadian Space Agency (CSA)/Canada.
- Centre National d’Etudes Spatiales (CNES)/France.
- China National Space Administration (CNSA)/People’s Republic of China.
- Deutsches Zentrum für Luft- und Raumfahrt (DLR)/Germany.
- European Space Agency (ESA)/Europe.
- Federal Space Agency (FSA)/Russian Federation.
- Instituto Nacional de Pesquisas Espaciais (INPE)/Brazil.
- Japan Aerospace Exploration Agency (JAXA)/Japan.
- National Aeronautics and Space Administration (NASA)/USA.
- UK Space Agency/United Kingdom.

Observer Agencies

- Austrian Space Agency (ASA)/Austria.
- Belgian Federal Science Policy Office (BFSP0)/Belgium.
- Central Research Institute of Machine Building (TsNIIMash)/Russian Federation.
- China Satellite Launch and Tracking Control General, Beijing Institute of Tracking and Telecommunications Technology (CLTC/BITTT)/China.
- Chinese Academy of Sciences (CAS)/China.
- China Academy of Space Technology (CAST)/China.
- Commonwealth Scientific and Industrial Research Organization (CSIRO)/Australia.
- Danish National Space Center (DNSC)/Denmark.
- Departamento de Ciência e Tecnologia Aeroespacial (DCTA)/Brazil.
- Electronics and Telecommunications Research Institute (ETRI)/Korea.
- European Organization for the Exploitation of Meteorological Satellites (EUMETSAT)/Europe.
- European Telecommunications Satellite Organization (EUTELSAT)/Europe.
- Geo-Informatics and Space Technology Development Agency (GISTDA)/Thailand.
- Hellenic National Space Committee (HNSC)/Greece.
- Hellenic Space Agency (HSA)/Greece.
- Indian Space Research Organization (ISRO)/India.
- Institute of Space Research (IKI)/Russian Federation.
- Korea Aerospace Research Institute (KARI)/Korea.
- Ministry of Communications (MOC)/Israel.
- Mohammed Bin Rashid Space Centre (MBRSC)/United Arab Emirates.
- National Institute of Information and Communications Technology (NICT)/Japan.
- National Oceanic and Atmospheric Administration (NOAA)/USA.
- National Space Agency of the Republic of Kazakhstan (NSARK)/Kazakhstan.
- National Space Organization (NSPO)/Chinese Taipei.
- Naval Center for Space Technology (NCST)/USA.
- Research Institute for Particle & Nuclear Physics (KFKI)/Hungary.
- Scientific and Technological Research Council of Turkey (TUBITAK)/Turkey.
- South African National Space Agency (SANSA)/Republic of South Africa.
- Space and Upper Atmosphere Research Commission (SUPARCO)/Pakistan.
- Swedish Space Corporation (SSC)/Sweden.
- Swiss Space Office (SSO)/Switzerland.

CCSDS RECOMMENDED STANDARD FOR
OPTICAL COMMUNICATIONS CODING AND SYNCHRONIZATION

- United States Geological Survey (USGS)/USA.

DOCUMENT CONTROL

Document	Title	Date	Status
CCSDS 142.0-B-1	Optical Communications Coding and Synchronization, Recommended Standard, Issue 1	August 2019	Original issue

CONTENTS

<u>Section</u>	<u>Page</u>
1 INTRODUCTION.....	1-1
1.1 PURPOSE.....	1-1
1.2 SCOPE.....	1-1
1.3 APPLICABILITY.....	1-1
1.4 RATIONALE.....	1-2
1.5 DOCUMENT STRUCTURE	1-2
1.6 DEFINITIONS.....	1-3
1.7 NOMENCLATURE	1-3
1.8 CONVENTIONS.....	1-4
1.9 REFERENCES	1-5
2 OVERVIEW.....	2-1
2.1 ARCHITECTURE.....	2-1
2.2 SUMMARY OF FUNCTIONS	2-2
2.3 INTERNAL ORGANIZATION OF TELEMETRY SIGNALING AT THE CODING AND SYNCHRONIZATION SUBLAYER.....	2-3
2.4 INTERNAL ORGANIZATION OF BEACON AND AOS/USLP TRANSFER FRAME SIGNALING AT THE CODING AND SYNCHRONIZATION SUBLAYER.....	2-5
3 HPE TELEMETRY SIGNALING.....	3-1
3.1 OVERVIEW	3-1
3.2 CCSDS TRANSFER FRAMES	3-3
3.3 ATTACHED SYNCHRONIZATION MARKER.....	3-3
3.4 SLICER.....	3-4
3.5 PSEUDO-RANDOMIZER.....	3-6
3.6 CRC ATTACHMENT.....	3-7
3.7 TERMINATION BINARY DIGITS ATTACHMENT.....	3-10
3.8 SCPPM ENCODER.....	3-10
3.9 CHANNEL INTERLEAVER.....	3-15
3.10 CODEWORD SYNCHRONIZATION MARKER.....	3-17
3.11 REPEAT	3-18
3.12 SLOT MAPPER	3-18
3.13 GUARD SLOT INSERTION	3-19
3.14 TRANSFER FRAME VALIDATION	3-19
3.15 SEQUENCE INDICATOR.....	3-19

CONTENTS (continued)

<u>Section</u>	<u>Page</u>
4 HPE BEACON AND OPTIONAL ACCOMPANYING DATA TRANSMISSION SIGNALING.....	4-1
4.1 OVERVIEW	4-1
4.2 INPUT TO CODING AND SYNCHRONIZATION SUBLAYER.....	4-3
4.3 ATTACHED SYNCHRONIZATION MARKER.....	4-3
4.4 SLICER.....	4-3
4.5 LDPC ENCODER	4-4
4.6 PSEUDO-RANDOMIZER.....	4-4
4.7 CHANNEL INTERLEAVER.....	4-5
4.8 CODEWORD SYNCHRONIZATION MARKER.....	4-5
4.9 PN SPREADER.....	4-5
4.10 2-PPM SLOT MAPPER.....	4-6
4.11 GUARD SLOT INSERTION	4-6
4.12 AOS/USLP TRANSFER FRAME VALIDATION AND SEQUENCE INDICATOR.....	4-7
5 MANAGED PARAMETERS	5-1
5.1 OVERVIEW	5-1
5.2 MANAGED PARAMETERS FOR TELEMETRY SIGNALING	5-1
5.3 MANAGED PARAMETERS FOR AOS/USLP TRANSFER FRAME SIGNALING	5-2
ANNEX A PROTOCOL IMPLEMENTATION CONFORMANCE STATEMENT PROFORMA (NORMATIVE).....	A-1
ANNEX B SERVICE (NORMATIVE).....	B-1
ANNEX C SECURITY, SANA, AND PATENT CONSIDERATIONS (INFORMATIVE)	C-1
ANNEX D ABBREVIATIONS AND TERMS (INFORMATIVE)	D-1
ANNEX E INFORMATIVE REFERENCES	E-1

Figure

1-1 Bit Numbering Convention.....	1-4
2-1 Relationship with OSI Layers.....	2-1
2-2 Overall Architecture of the Optical Communications System	2-3
2-3 Internal Organization of Telemetry Signaling at the Sending End.....	2-3
2-4 Internal Organization of Telemetry Signaling at the Receiving End.....	2-4

CONTENTS (continued)

<u>Figure</u>	<u>Page</u>
2-5 Internal Organization of AOS/USLP Transfer Frame Signaling at the Sending End	2-6
2-6 Internal Organization of the AOS/USLP Transfer frame Signaling at the Receiving End	2-7
3-1 Functional Diagram for Telemetry Signaling	3-2
3-2 ASM Attachment	3-3
3-3 Slicer	3-4
3-4 Pseudo-Randomizer Data Flow	3-6
3-5 Shift Register Implementation of CRC Attachment	3-9
3-6 SCPPM Encoder Input Block	3-10
3-7 SCPPM Encoder	3-10
3-8 Encoder for Rate 1/3 Mother Convolutional Encoder	3-11
3-9 The Accumulator	3-13
3-10 Convolutional Channel Interleaver	3-15
3-11 Guard Slot Insertion	3-19
4-1 Functional Diagram for AOS/USLP Transfer Frame Signaling	4-2

Table

3-1 Information Block Sizes	3-4
3-2 Convolutional Encoder Puncture Patterns	3-12
4-1 PN Sequence	4-6
5-1 Managed Parameters for HPE Telemetry Signaling	5-1
5-2 Managed Parameters for HPE AOS/USLP Transfer Frame Signaling	5-2

1 INTRODUCTION

1.1 PURPOSE

The purpose of this Recommended Standard is to specify the channel coding and synchronization schemes for free space optical communications systems used by space missions. The primary application addressed in this issue of the Recommended Standard is space-to-ground and ground-to-space photon-starved links through an atmospheric channel; use of the Recommended Standard for other applications or operating conditions is not precluded.

In photon-starved links, the photon-efficiency of the link is of primary concern. When provided with a set of CCSDS transfer frames produced by the Data Link Protocol Sublayer (as specified in reference [1], [2], or [8]), this specification allows one to determine the binary vector to be provided to the Physical Layer. The ‘ones’ and ‘zeroes’ of the binary vector indicate the slots that are to be pulsed and non-pulsed, respectively, in the optical transmission. The physical characteristics of such transmissions are addressed in *Optical Communications Physical Layer* (reference [3]).

1.2 SCOPE

This Recommended Standard defines Coding and Synchronization Sublayer schemes in terms of the signal characteristics and procedures involved in the encoding and synchronization of the optical signals. It does not specify

- a) individual implementations or products;
- b) the methods or technologies required to perform the procedures; or
- c) the management activities required to configure and control the system.

Issue 1 includes a specification for High Photon Efficiency (HPE) systems, in which the photon-efficiency of the link is of primary concern.¹

1.3 APPLICABILITY

This Recommended Standard applies to the creation of Agency standards and to the future data communications over optical space links between CCSDS Agencies in cross-support situations. It includes comprehensive specifications of the data formats and procedures for inter-Agency cross support. It is neither a specification of nor a design for real systems that may be implemented for existing or future missions.

The Recommended Standard specified in this document is to be invoked through the normal standards program of each CCSDS Agency and is applicable to those missions for which

¹ A subsequent issue of this Recommended Standard may provide a specification for low-complexity and/or high-data-rate optical communications.

cross support based on capabilities described in this Recommended Standard is anticipated. Where mandatory capabilities are clearly indicated in sections of this Recommended Standard, they must be implemented when this document is used as a basis for cross support. Where options are allowed or implied, implementation of these options is subject to specific bilateral cross-support agreements between the Agencies involved.

1.4 RATIONALE

This Recommended Standard facilitates cross support at the Coding and Synchronization Sublayer of optical communications systems used by CCSDS Member Agencies. Such cross support requires specification of the slicing of transfer frames, synchronization markers, channel encoding, modulation, channel interleaving, slot mapping, and guard slot insertion, among other details of the Coding and Synchronization Sublayer.

The CCSDS believes it is important to document the rationale underlying the recommendations chosen so that future evaluations of proposed changes or improvements will not lose sight of previous decisions. The rationale for the specifications making up this Recommended Standard is expected to be documented in a forthcoming CCSDS Informational Report.

1.5 DOCUMENT STRUCTURE

This document is divided into five numbered sections and five annexes:

- a) section 1 presents the purpose, scope, applicability, rationale, document structure, definitions, nomenclature, conventions, and references;
- b) section 2 provides an overview of the architecture and summary of functions of the optical Coding and Synchronization Sublayer;
- c) section 3 specifies HPE telemetry signaling;
- d) section 4 specifies HPE beacon and optional Advanced Orbiting Systems (AOS) transfer frame signaling;
- e) section 5 lists the managed parameters;
- f) annex A is the Protocol Implementation Conformance Statement (PICS) proforma;
- g) annex B defines the service provided to the users;
- h) annex C discusses security, SANA, and patent considerations;
- i) annex D lists abbreviations and terms used within this document;
- j) annex E provides a list of informative references.

1.6 DEFINITIONS

1.6.1 DEFINITIONS FROM THE OPEN SYSTEM INTERCONNECTION BASIC REFERENCE MODEL

This Recommended Standard makes use of a number of terms defined in reference [4]. The use of those terms in this Recommended Standard is to be understood in a generic sense, that is, in the sense that those terms are generally applicable to any of a variety of technologies that provide for the exchange of information between real systems. Those terms are

- a) Data Link Layer;
- b) Physical Layer;
- c) service; and
- d) service data unit.

1.6.2 DEFINITIONS FROM OPEN SYSTEM INTERCONNECTION SERVICE DEFINITION CONVENTIONS

This Recommended Standard makes use of a number of terms defined in reference [5]. The use of those terms in this Recommended Standard is to be understood in a generic sense, that is, in the sense that those terms are generally applicable to any of a variety of technologies that provide for the exchange of information between real systems. Those terms are

- a) indication;
- b) primitive;
- c) request;
- d) service provider; and
- e) service user.

1.7 NOMENCLATURE

1.7.1 NORMATIVE TEXT

The following conventions apply throughout this Specification:

- a) the words 'shall' and 'must' imply a binding and verifiable specification;
- b) the word 'should' implies an optional, but desirable, specification;
- c) the word 'may' implies an optional specification;
- d) the words 'is', 'are', and 'will' imply statements of fact.

1.7.2 INFORMATIVE TEXT

In the normative sections of this document, informative text is set off from the normative specifications either in notes or under one of the following subsection headings:

- Overview;
- Background;
- Rationale;
- Discussion.

1.8 CONVENTIONS

In this document, the following convention is used to identify each bit in an N -bit field. The first bit in the field to be transmitted (i.e., the most left justified when drawing a figure) is defined to be ‘Bit 0’, the following bit is defined to be ‘Bit 1’, and so on, up to ‘Bit $N-1$ ’. When the field is used to express a binary value (such as a counter), the Most Significant Bit (MSB) shall be the first transmitted bit of the field, that is, ‘Bit 0’ (see figure 1-1).

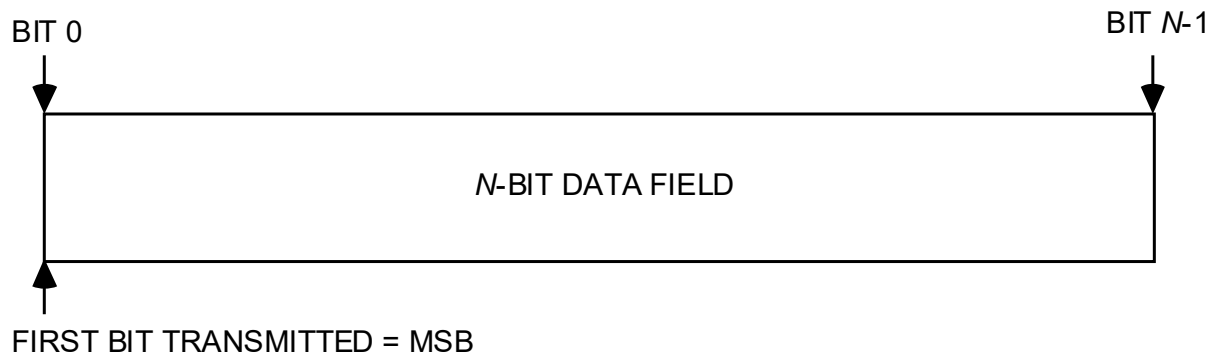

Figure 1-1: Bit Numbering Convention

In accordance with standard data-communications practice, data fields are often grouped into 8-bit ‘words’ that conform to the above convention. Throughout this specification, such an 8-bit word is called an ‘octet’. The numbering for octets within a data structure starts with ‘0’.

NOTE – Throughout this document, ‘bit’ refers to the contents of the transfer frames. A bit is a binary digit transferred between the Data Link Protocol Sublayer and the Coding and Synchronization Sublayer. Other symbols, whether binary or nonbinary, are referred to by other names, such as ‘binary digits’. It should be understood that the ordering conventions described above apply equally to other types of symbols.

1.9 REFERENCES

The following publications contain provisions which, through reference in this text, constitute provisions of this Recommended Standard. At the time of publication, the editions indicated were valid. All documents are subject to revision, and users of this Recommended Standard are encouraged to investigate the possibility of applying the most recent editions of the documents indicated below. The CCSDS Secretariat maintains a register of currently valid CCSDS documents.

- [1] *TM Space Data Link Protocol*. Issue 2. Recommendation for Space Data System Standards (Blue Book), CCSDS 132.0-B-2. Washington, D.C.: CCSDS, September 2015.
- [2] *AOS Space Data Link Protocol*. Issue 3. Recommendation for Space Data System Standards (Blue Book), CCSDS 732.0-B-3. Washington, D.C.: CCSDS, September 2015.
- [3] *Optical Communications Physical Layer*. Issue 1. Recommendation for Space Data System Standards (Blue Book), CCSDS 141.0-B-1. Washington, D.C.: CCSDS, August 2019.
- [4] *Information Technology—Open Systems Interconnection—Basic Reference Model: The Basic Model*. 2nd ed. International Standard, ISO/IEC 7498-1:1994. Geneva: ISO, 1994.
- [5] *Information Technology—Open Systems Interconnection—Basic Reference Model—Conventions for the Definition of OSI Services*. International Standard, ISO/IEC 10731:1994. Geneva: ISO, 1994.
- [6] *TC Synchronization and Channel Coding*. Issue 3. Recommendation for Space Data System Standards (Blue Book), CCSDS 231.0-B-3. Washington, D.C.: CCSDS, September 2017.
- [7] *TM Synchronization and Channel Coding*. Issue 3. Recommendation for Space Data System Standards (Blue Book), CCSDS 131.0-B-3. Washington, D.C.: CCSDS, September 2017.
- [8] *Unified Space Data Link Protocol*. Issue 1. Recommendation for Space Data System Standards (Blue Book), CCSDS 732.1-B-1. Washington, D.C.: CCSDS, October 2018.

2 OVERVIEW

2.1 ARCHITECTURE

Figure 2-1 illustrates the relationship of this Recommended Standard to the Open System Interconnection (OSI) reference model (reference [4]). Two sublayers of the Data Link Layer are defined for CCSDS space link protocols. The Data Link Protocol Sublayer provides functions for producing transfer frames; possible Space Data Link Protocols using optical communications are the Telemetry (TM) Space Data Link Protocol (reference [1]), the AOS Space Data Link Protocol (reference [2]), and the Unified Space Data Link Protocol (USLP) (reference [8]). The Optical Communications Coding and Synchronization Protocol specified in this Recommended Standard provides the functions of the Synchronization and Channel Coding Sublayer of the Data Link Layer for transferring transfer frames over an optical space link.

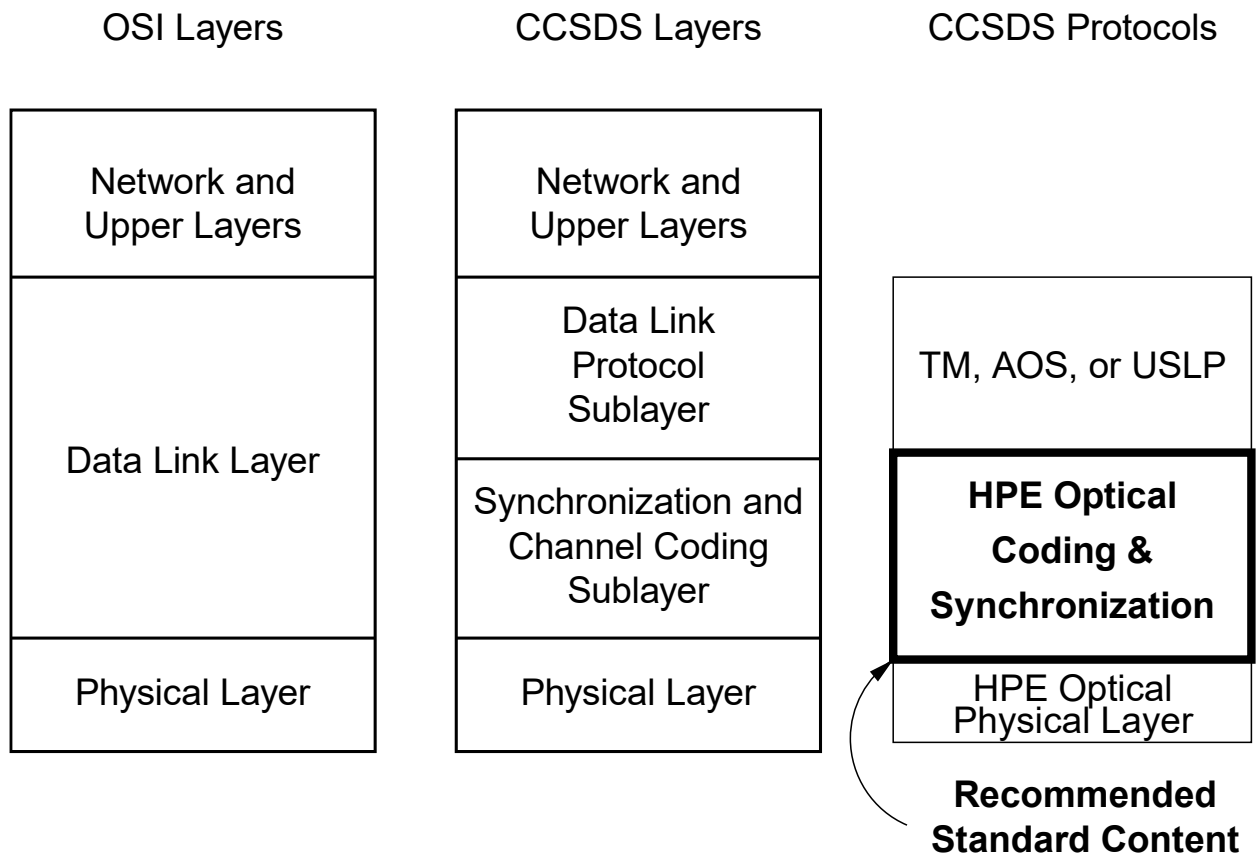

Figure 2-1: Relationship with OSI Layers

2.2 SUMMARY OF FUNCTIONS

The Optical Coding and Synchronization Sublayer provides the following functions for transferring transfer frames over an optical space link:

- a) channel coding;
- b) synchronization; and
- c) telemetry transfer frame validation.

This Recommended Standard includes a specification for the transmission of telemetry transfer frames, AOS transfer frames, or fixed-length USLP transfer frames, and a separate specification for beacon and optional transmission of AOS transfer frames or fixed-length USLP transfer frames. In a typical implementation, telemetry signaling would occur from space to ground (downlink), and beacon and optional AOS/USLP transfer frame signaling would occur from ground to space (uplink), but this Recommended Standard does not prescribe the link direction or geometry. These transmissions occur simultaneously and continuously at opposite ends of the link during each communications session.

The telemetry specification defines the relationship between input CCSDS transfer frames and output pulsed slots. For the HPE application, this specification includes the following functions: CCSDS transfer frame slicer, CRC, channel coding including frame validation, modulation, channel interleaver, codeword synchronization marker, repeat, slot mapper, and guard slot insertion.

The beacon specification includes optional transmission of AOS/USLP transfer frames. The specification defines the relationship between sending-end input frames (from upper layer) and output pulsed slots (to lower layer). The specification includes functions to: 1) provide a reference beacon, 2) aid synchronization, and 3) support an AOS/USLP transfer frame transmission capability.

The overall architecture of the optical communications system is shown in figure 2-2. Throughout the communications session, the optical Terminal A transmits a beacon, together with optional AOS/USLP transfer frame data. The Terminal B receiver locks onto the beacon and uses it to assist in accurately pointing its optical transmitter. Any AOS/USLP transfer frame data is also decoded onboard. Telemetry is transmitted from Terminal B and received by Terminal A.

This Recommended Standard specifies the coding and synchronization features of the Terminal A and Terminal B transmitters, and a few details of the functions required at the receivers, including frame validation. In a typical application, Terminal A on the ground transmits an uplink beacon and optional AOS/USLP transfer frame data to Terminal B in space, and Terminal B transmits a downlink telemetry signal to Terminal A.

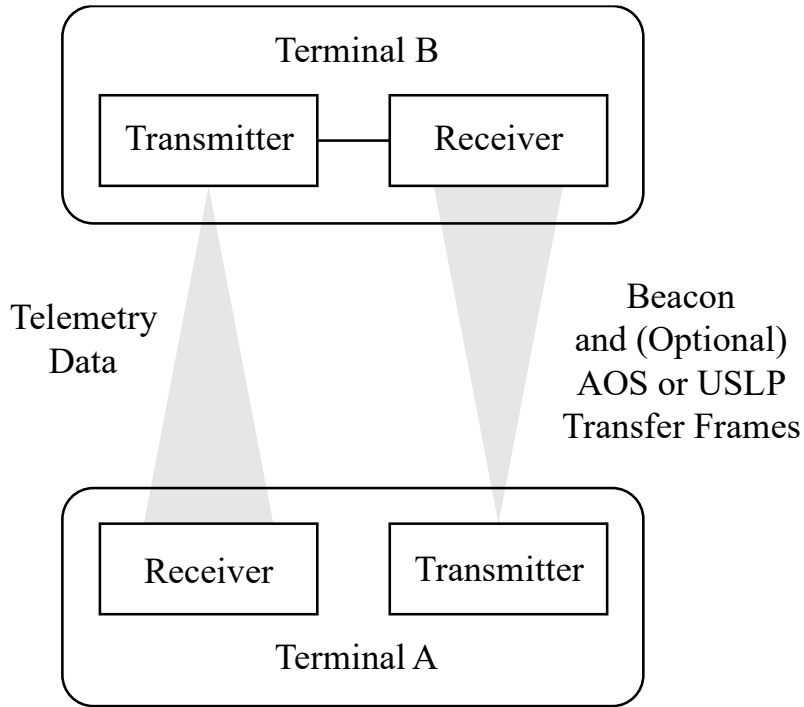

Figure 2-2: Overall Architecture of the Optical Communications System

2.3 INTERNAL ORGANIZATION OF TELEMTRY SIGNALING AT THE CODING AND SYNCHRONIZATION SUBLAYER

2.3.1 TELEMTRY SIGNALING AT THE SENDING END

Figure 2-3 shows the internal organization of the Coding and Synchronization Sublayer of telemetry signaling at the sending end. This figure identifies functions performed by the sublayer and shows logical relationships among these functions. The figure is not intended to imply any hardware or software configuration in a real system.

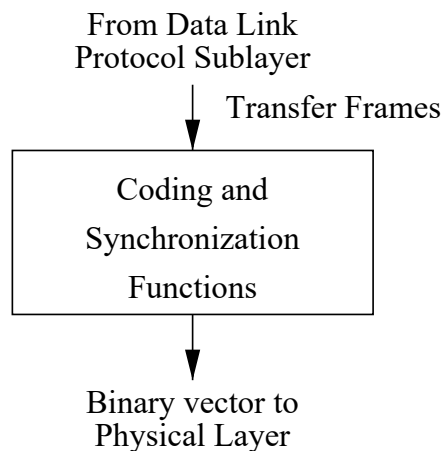

Figure 2-3: Internal Organization of Telemetry Signaling at the Sending End

At the sending end, the Coding and Synchronization Sublayer accepts transfer frames of fixed length and constant rate from the Data Link Protocol Sublayer (see figure 2-1), performs functions selected for the mission, and delivers a binary vector to the Physical Layer to indicate which slots are to contain light pulses.

2.3.2 TELEMETRY SIGNALING AT THE RECEIVING END

2.3.2.1 General

Figure 2-4 shows the internal organization of the Coding and Synchronization Sublayer for telemetry signaling at the receiving end. This figure identifies functions performed by the sublayer and shows logical relationships among these functions. The figure is not intended to imply any hardware or software configuration in a real system. Organization of CCSDS optical communications sublayering differs from that of the CCSDS protocol specifications for Radio Frequency (RF) communications in that the demodulation function is specified at the Coding and Synchronization Sublayer (this document) rather than at the Physical Layer (reference [3]).

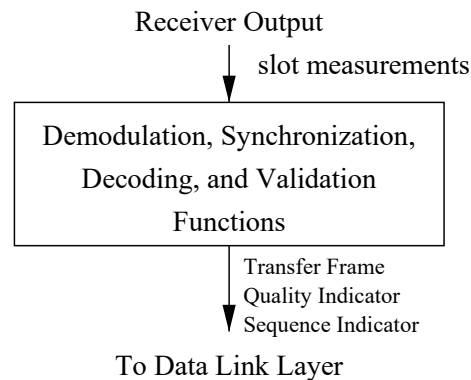

Figure 2-4: Internal Organization of Telemetry Signaling at the Receiving End

At the receiving end, the Coding and Synchronization Sublayer accepts receiver outputs from the Physical Layer and performs functions selected for the mission. The receiver outputs are slot measurements, which are receiver estimates of the intensity of light, number of photons observed, or related statistic, for each slot of the received transmission. Among these functions is codeword synchronization and Serially Concatenated convolutionally coded Pulse Position Modulation (SCPPM) decoding, from which Synchronization-Marked Transfer Frames (SMTFs) are recovered. Synchronization Markers present in the SMTF allow synchronization and recovery of each transfer frame, which is delivered to the Data Link Protocol Sublayer along with a quality indicator and sequence indication.

2.3.2.2 Telemetry Transfer Frame Validation

After SCPPM decoding and transfer frame recovery is performed, the upper layers at the receiving end also need to know whether or not each recovered transfer frame can be used as a valid data unit; that is, an indication of the quality of the received frame is needed. This function is called Transfer Frame Validation and produces the Quality Indicator.

The SCPPM decoder can determine, with a very high probability, whether or not each SCPPM codeword can be correctly decoded. Any transfer frames that are recovered from only correctly decoded SCPPM codewords are marked valid; transfer frames recovered from one or more incorrectly decoded codewords are marked invalid.

NOTE – The Frame Error Control Field defined in reference [1], [2], or [8] may also be used for additional frame validation in the Data Link Protocol Sublayer.

2.3.2.3 Synchronization

This Recommended Standard specifies a method for synchronizing telemetry transfer frames using an Attached Synchronization Marker (ASM) (see 3.3).

2.4 INTERNAL ORGANIZATION OF BEACON AND AOS/USLP TRANSFER FRAME SIGNALING AT THE CODING AND SYNCHRONIZATION SUBLAYER

2.4.1 AOS/USLP TRANSFER FRAME SIGNALING AT THE SENDING END

Figure 2-5 shows the internal organization of AOS/USLP transfer frame signaling at the Coding and Synchronization Sublayer of the sending end. This figure identifies functions performed by the sublayer and shows logical relationships among these functions. The figure is not intended to imply any hardware or software configuration in a real system.

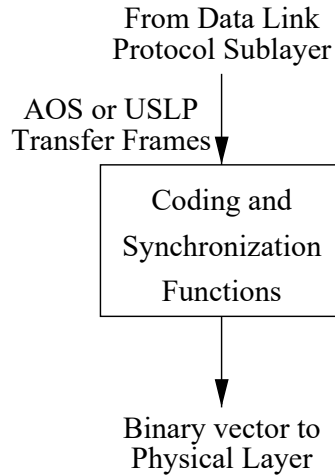

Figure 2-5: Internal Organization of AOS/USLP Transfer Frame Signaling at the Sending End

At the sending end, the Coding and Synchronization Sublayer accepts AOS or USLP fixed-length transfer frames from the Data Link Protocol Sublayer (see figure 2-5). It then performs functions selected for the mission and generates Low-Density Parity-Check (LDPC) encoded Synchronization-Marked Codewords (SMCWs). These SMCWs are Pseudo-random Noise (PN)-spread and mapped into 2-Pulse Position Modulation (2-PPM) symbols. Two guard slots are inserted to the 2-PPM symbol stream and sent to the Physical Layer.

2.4.2 AOS/USLP TRANSFER FRAME SIGNALING AT THE RECEIVING END

2.4.2.1 General

Figure 2-6 shows the internal organization of AOS/USLP transfer frame signaling at the Coding and Synchronization Sublayer of the receiving end. This figure identifies functions performed by the sublayer and shows logical relationships among these functions. The figure is not intended to imply any hardware or software configuration in a real system.

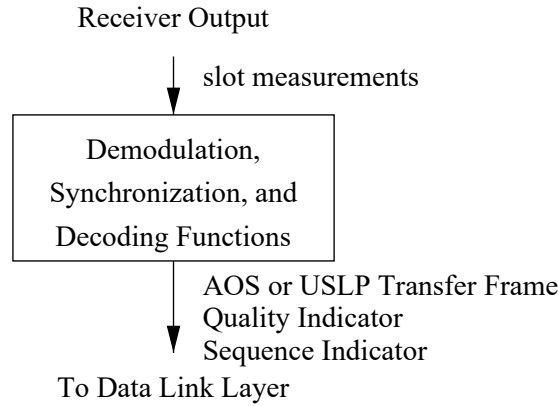

Figure 2-6: Internal Organization of the AOS/USLP Transfer frame Signaling at the Receiving End

At the receiving end, the Coding and Synchronization Sublayer accepts receiver outputs from the Physical Layer and performs functions selected for the mission. Among these functions is binary pulse position modulation (2-PPM), codeword synchronization, LDPC decoding, and AOS transfer frame synchronization. The recovered AOS/USLP transfer frames are recovered and delivered to the Data Link Protocol Sublayer, along with a quality indicator and sequence indication.

2.4.2.2 Synchronization

This Recommended Standard specifies a method for synchronizing transfer frames using an ASM (see 4.3).

3 HPE TELEMETRY SIGNALING

3.1 OVERVIEW

This Recommended Standard operates by taking CCSDS TM, AOS, or USLP transfer frames as input and producing a binary vector indicating the positions of pulsed slots as output to the Physical Layer.

No intervening slots (data or fill) are added to this output; if needed, zero fill is implemented at transmission closure by the Coding and Synchronization Sublayer. The functional blocks of the architecture at the sending end are shown in figure 3-1, along with the notation used in the following subsections that defines these functions mathematically. It should be understood that the functions need not be implemented explicitly as defined here; any implementation producing the proper pattern of pulsed slots complies with the standard.

As shown in figure 3-1, an ASM is prepended to each transfer frame. The bit pattern of the ASM and its insertion are defined in 3.3, and the data unit that consists of the ASM and the transfer frame is called the Synchronization-Marked Transfer Frame (SMTF). The ASM will be eventually encoded. The stream of SMTFs is sliced into Information Blocks that are pseudo-randomized. Then a CRC and termination bits are attached to each pseudo-randomized information block and provided as input to the Channel Encoder, as described later in this section. The PPM symbols composing the generated codewords are interleaved, and a Codeword Synchronization Marker (CSM) is prepended to each interleaved codeword, as shown in figure 3-1. Each PPM symbol is then repeated and mapped into a binary vector of length M to generate a vector of pulsed slots. Guard slots are inserted after each PPM symbol.

At the receiving end on the ground, two levels of synchronization are required: codeword synchronization (identified by the CSM) and transfer frame synchronization (identified by the ASM). CSM Synchronization is achieved by recognizing the specific bit pattern of the CSM in the symbol stream. This synchronization is then verified by making further checks. The codeword and codeword lengths are fixed and managed for a given phase of a mission. The detailed steps are described in the next subsections. Details of much of the theory and implementation are described in informative reference [E1].

CCSDS RECOMMENDED STANDARD FOR
OPTICAL COMMUNICATIONS CODING AND SYNCHRONIZATION

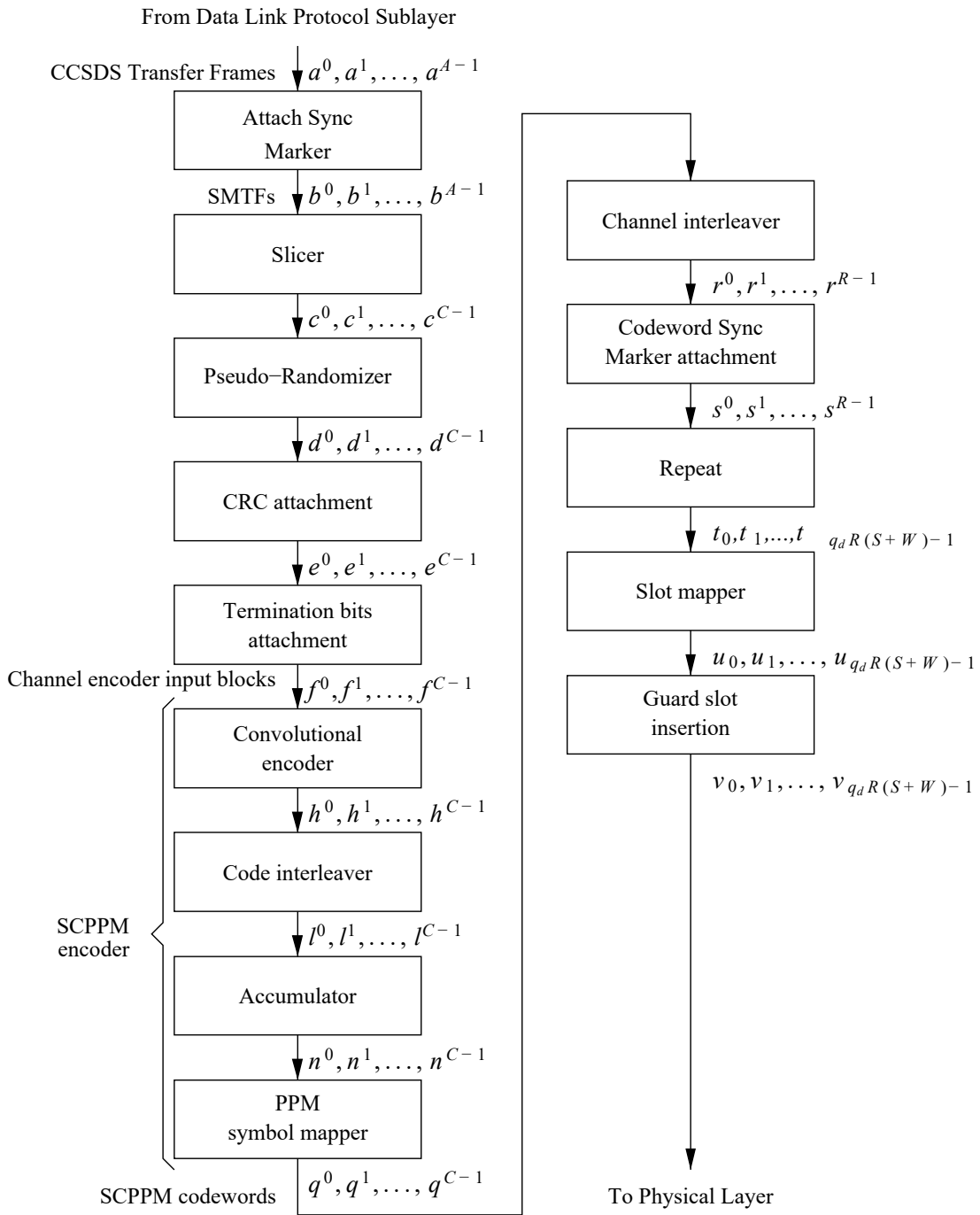

Figure 3-1: Functional Diagram for Telemetry Signaling

3.2 CCSDS TRANSFER FRAMES

The input to the Coding and Synchronization Sublayer shall be a sequence of CCSDS transfer frames with structure as defined in references [1], [2], and [8], and is denoted by

$$\mathbf{a}^0, \mathbf{a}^1, \dots, \mathbf{a}^{A-1};$$

and for $i \in \{0, 1, \dots, A-1\}$, the i^{th} transfer frame is denoted

$$\mathbf{a}^i = a_0^i, a_1^i, \dots, a_{T_i-1}^i,$$

where $a_j^i \in \{0, 1\}$ is the j^{th} bit of the i^{th} frame, and T_i is the number of bits in the i^{th} frame.

NOTE – The encoding described in this subsection may be performed in a streaming fashion; that is, not all A transfer frames of a full communications session need be available at the time encoding is begun, and the value of A need not be known a priori.

3.3 ATTACHED SYNCHRONIZATION MARKER

3.3.1 ATTACHMENT METHOD

A 32-binary-digit ASM shall be prepended to each transfer frame, resulting in an SMTF, as follows: For $i \in \{0, 1, \dots, A-1\}$ the i^{th} SMTF is denoted

$$\mathbf{b}^i = b_0^i, b_1^i, \dots, b_{B_i-1}^i,$$

where $B_i = T_i + 32$ and

$$b_j^i = \begin{cases} s_j, & \text{if } 0 \leq j < 32 \\ a_{j-32}^i, & \text{if } 32 \leq j < B_i \end{cases}.$$

NOTE – Construction of SMTFs is shown in figure 3-2.

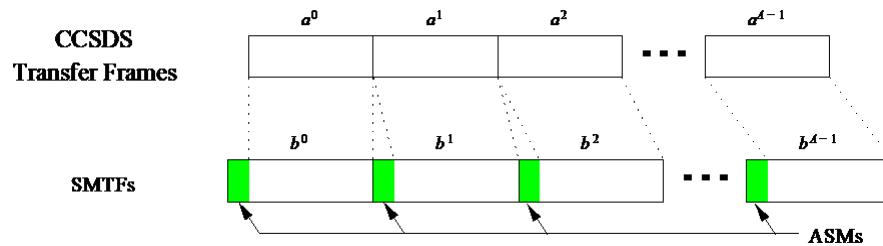

Figure 3-2: ASM Attachment

3.3.2 SEQUENCE SPECIFICATION

The ASM shall be the sequence $s = s_0, s_1, \dots, s_{31}$, represented in hexadecimal notation as

$$s = 1ACFFC1D.$$

3.4 SLICER

3.4.1 SLICING LENGTH

The sequence of SMTFs shall be sliced into information blocks of length k , where k is determined by the code rate $r \in \{1/3, 1/2, 2/3\}$ (see table 3-1), which is a managed parameter. The last information block may be less than k .

Table 3-1: Information Block Sizes

Code Rate	Information block size	Length of information blocks with CRC-32 and 2-binary-digit termination added
r	k	\hat{k}
1/3	5006	5040
1/2	7526	7560
2/3	10046	10080

3.4.2 ZERO FILL

3.4.2.1 Slicer Output

3.4.2.1.1 At transmission closure, the slicer output shall be zero-filled with the minimum number of ‘zeroes’ so that its length is a multiple of k .

NOTES

- The slicing and zero fill is as shown in figure 3-3 and described herein.

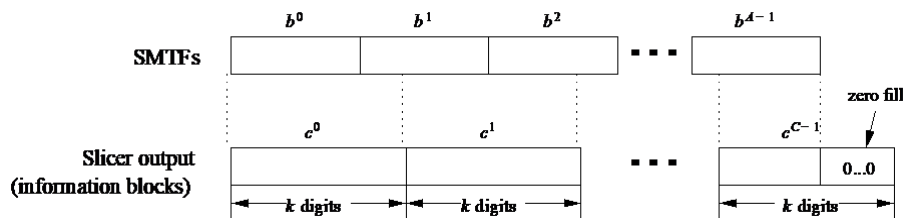

Figure 3-3: Slicer

2 The sequence of SMTFs,

$$\mathbf{b}^0, \mathbf{b}^1, \dots, \mathbf{b}^{A-1},$$

is a vector of vectors that can be viewed as a single vector with binary digits in the same order,

$$\hat{\mathbf{b}} = \hat{b}_0, \hat{b}_1, \dots, \hat{b}_{B-1},$$

where $B = \sum_{i=0}^{A-1} B_i$. The sequence $\hat{\mathbf{b}}$ is filled at its end with the minimum number of ‘zeroes’ so that its length is a multiple of k . The sequence $\tilde{\mathbf{b}}$ is denoted by

$$\tilde{\mathbf{b}} = \hat{b}_0, \hat{b}_1, \dots, \hat{b}_{B-1}, \underbrace{0, 0, \dots, 0}_P,$$

where

$$\tilde{b}_i = \begin{cases} \hat{b}_i, & \text{if } 0 \leq i < B \\ 0, & \text{if } B \leq i < B + P \end{cases},$$

and

$$P = \min\{p : k \mid B + p\}.$$

3.4.2.1.2 The slicer shall reindex $\tilde{\mathbf{b}}$ into $C = (B + P)/k$ blocks each of length k :

$$\mathbf{c}^0, \mathbf{c}^1, \dots, \mathbf{c}^{C-1},$$

where for $i \in \{0, 1, \dots, C - 1\}$ the i^{th} block is denoted $\mathbf{c}^i = c_0^i, c_1^i, \dots, c_{k-1}^i$, and for $j \in \{0, 1, \dots, k - 1\}$ the j^{th} symbol of the i^{th} block is

$$c_j^i = \tilde{b}_{ki+j}.$$

3.5 PSEUDO-RANDOMIZER

3.5.1 DESCRIPTION

3.5.1.1 Each k -digit information block from the slicer shall be pseudo-randomized by performing the digit-wise modulo-2 addition with a pseudo-random sequence, as shown in figure 3-4 and described herein.

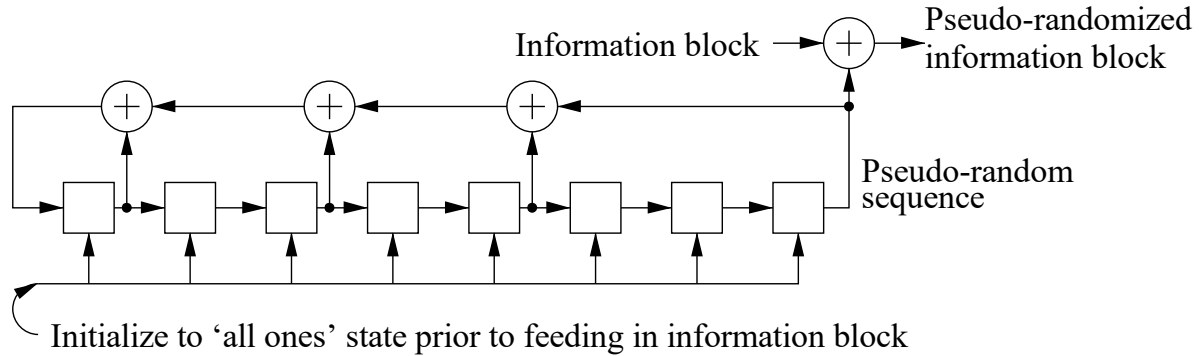

Figure 3-4: Pseudo-Randomizer Data Flow

3.5.1.2 For $i \in \{0, 1, \dots, C - 1\}$, the i^{th} pseudo-randomized information block is denoted $\mathbf{d}^i = d_0^i, d_1^i, \dots, d_{k-1}^i$, where for $j \in \{0, 1, \dots, k - 1\}$, the j^{th} symbol of the i^{th} block is

$$d_j^i = c_j^i \oplus p_j,$$

where \oplus represents modulo-2 addition and p_j is defined in 3.5.2.

3.5.2 SEQUENCE SPECIFICATION

3.5.2.1 The pseudo-random sequence p_0, p_1, \dots, p_{k-1} shall be generated by the polynomial:

$$g(D) = D^8 + D^7 + D^5 + D^3 + 1.$$

NOTE – The sequence is the same one specified in reference [7]. It is periodic with period 255. The first 40 binary digits of the pseudo-random sequence are

$$p_0, p_1, \dots, p_{39} = 1111\ 1111\ 0100\ 1000\ 0000\ 1110\ 1100\ 0000\ 1001\ 1010$$

3.5.3 SEQUENCE INITIALIZATION

3.5.3.1 This sequence shall begin at the first digit of the information block and shall repeat after 255 binary digits, continuing repeatedly until the end of the information block.

3.5.3.2 The sequence generator shall be initialized to the ‘all ones’ state at the start of each information block.

3.6 CRC ATTACHMENT

3.6.1 DESCRIPTION

3.6.1.1 Thirty-two Cyclic Redundancy Check (CRC) binary digits shall be appended to the end of each pseudo-randomized information block as shown in figure 3-5 and described herein.

3.6.1.2 The i^{th} pseudo-randomized information block with the attached CRC is $e^i = e_0^i, e_1^i, \dots, e_{k+31}^i$, where

$$e_j^i = \begin{cases} d_j^i, & \text{if } 0 \leq j < k \\ z_{j-k}^i, & \text{if } k \leq j < k+32 \end{cases},$$

where z_{j-k}^i is defined in 3.6.2.

3.6.2 CRC SEQUENCE SPECIFICATION

3.6.2.1 The CRC parity binary digits shall be computed as follows: For $i \in \{0, 1, \dots, C-1\}$, the i^{th} pseudo-randomized information block d^i is padded with 32 ‘zeroes’ and expressed in polynomial notation as

$$d^i(X) = d_0^i X^{k+31} + d_1^i X^{k+30} + \dots + d_{k-2}^i X^{33} + d_{k-1}^i X^{32}.$$

3.6.2.2 The polynomial notation for the thirty-two binary digit CRC is

$$z^i(X) = z_0^i X^{31} + z_1^i X^{30} + \dots + z_{30}^i X + z_{31}^i$$

and is given by

$$z^i(X) = \left[d^i(X) + \sum_{j=0}^{31} X^{k+j} \right] \text{mod } h(X),$$

where all arithmetic is modulo 2 and $h(X)$ is the generator polynomial given by

$$h(X) = X^{32} + X^{29} + X^{18} + X^{14} + X^3 + 1.$$

CCSDS RECOMMENDED STANDARD FOR
OPTICAL COMMUNICATIONS CODING AND SYNCHRONIZATION

NOTES

- 1 In the expression, for $z^i(X)$ the $\sum_{j=0}^{31} X^{k+j}$ term has the effect of presetting the shift registers to 'all ones' prior to encoding.
- 2 A possible technique for generating the CRC binary digits is given in figure 3-5. For each pseudo-randomized information block, the shift register cells are initialized to '1'. The ganged switch is in position (1) while the k pseudo-randomized information digits are being transferred and in position (2) for the thirty-two CRC digits.

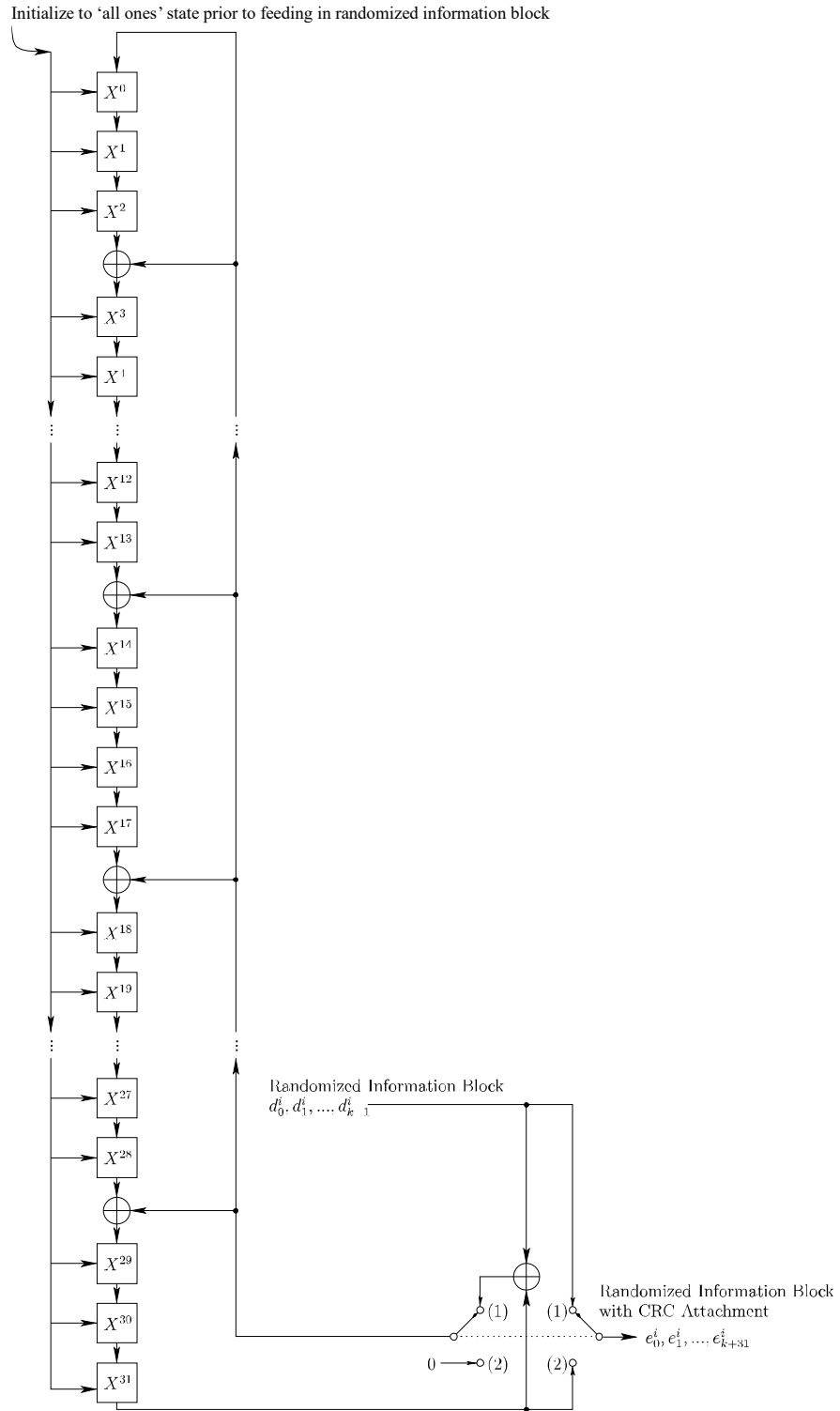

Figure 3-5: Shift Register Implementation of CRC Attachment

3.8.2 CONVOLUTIONAL ENCODER

3.8.2.1 Generator Polynomial

The SCPPM outer code shall be a constraint-length-three convolutional code defined by the generator polynomials

$$\begin{aligned} g^{(1)}(D) &= 1 + D^2 \\ g^{(2)}(D) &= 1 + D + D^2 \\ g^{(3)}(D) &= 1 + D + D^2, \end{aligned}$$

or [5, 7, 7] in octal notation.

NOTES

- 1 The encoder for this rate 1/3 mother code is shown in figure 3-8.

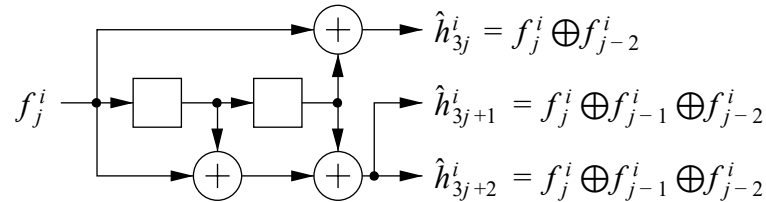

Figure 3-8: Encoder for Rate 1/3 Mother Convolutional Encoder

- 2 The j^{th} binary digit of the i^{th} SCPPM encoder input block, f_j^i , enters the convolutional encoder, which in response produces the three code symbols $\hat{h}_{3j}^i, \hat{h}_{3j+1}^i, \hat{h}_{3j+2}^i$ corresponding to the polynomials $g^{(1)}(D), g^{(2)}(D), g^{(3)}(D)$, respectively. After all \hat{k} binary digits of f^i enter the encoder, the encoder has produced the convolutional codeword

$$\hat{\mathbf{h}}^i = \hat{h}_0^i, \hat{h}_1^i, \dots, \hat{h}_{3\hat{k}-1}^i.$$

3.8.2.2 Initialization

The encoder shall be initialized to the ‘all zeroes’ state prior to encoding each input block.

NOTE – For each input block after the first, the initialization to ‘all zeroes’ happens naturally because of the termination digits used in the preceding input block.

3.8.2.3 Puncturing

3.8.2.3.1 The rate 1/3 code may be punctured, resulting in a rate 1/2 or rate 2/3 code, using the puncture patterns given in table 3-2.

Table 3-2: Convolutional Encoder Puncture Patterns

Rate	P_0	P_1	P_2	P_3	P_4	P_5
1/3	1	1	1	1	1	1
1/2	1	1	0	1	1	0
2/3	1	1	0	0	1	0

3.8.2.3.2 The puncturing shall be accomplished using the following procedure:

```

j ← 0
for m ← 0 to 3 $\hat{k}$  - 1
    if ( $P_{m \bmod 6} \equiv 1$ )
         $h_j^i \leftarrow \hat{h}_m^i$ 
        j ← j + 1
    endif
endfor
    
```

NOTES

1 The rate 1/2 code punctures every 3rd code symbol \hat{h}_{3j+2}^i :

$$\hat{h}_0^i, \hat{h}_1^i, \hat{h}_2^i, \hat{h}_3^i, \hat{h}_4^i, \hat{h}_5^i, \dots, \hat{h}_{3\hat{k}-6}^i, \hat{h}_{3\hat{k}-5}^i, \hat{h}_{3\hat{k}-4}^i, \hat{h}_{3\hat{k}-3}^i, \hat{h}_{3\hat{k}-2}^i, \hat{h}_{3\hat{k}-1}^i.$$

The rate 2/3 code additionally punctures every other first code symbol \hat{h}_{6j+3}^i :

$$\hat{h}_0^i, \hat{h}_1^i, \hat{h}_2^i, \hat{h}_3^i, \hat{h}_4^i, \hat{h}_5^i, \dots, \hat{h}_{3\hat{k}-6}^i, \hat{h}_{3\hat{k}-5}^i, \hat{h}_{3\hat{k}-4}^i, \hat{h}_{3\hat{k}-3}^i, \hat{h}_{3\hat{k}-2}^i, \hat{h}_{3\hat{k}-1}^i.$$

The resulting i^{th} convolutional codeword is denoted

$$\mathbf{h}^i = h_0^i, h_1^i, \dots, h_{15119}^i.$$

2 \hat{k} is defined so that, regardless of rate, each convolutional codeword has length 15120.

3.8.3 CODE INTERLEAVER

3.8.3.1 The binary symbols of each 15120-symbol convolutional codeword shall be permuted by a 15120-binary-symbol block interleaver as follows: For $i \in \{0, 1, \dots, C - 1\}$, the i^{th} interleaved codeword is denoted $\mathbf{l}^i = l_0^i, l_1^i, \dots, l_{15119}^i$.

3.8.3.2 For $j \in \{0, 1, \dots, 15119\}$, the j^{th} code symbol of the i^{th} interleaved codeword shall be

$$l_j^i = h_{\pi(j)}^i,$$

where

$$\pi(j) = (11j + 210j^2) \bmod 15120.$$

3.8.3.3 The interleaver may be implemented by writing code symbols sequentially to positions 0 through 15119 and by reading code symbols in interleaved order from positions $\pi(0)$ through $\pi(15119)$.

NOTE – The code interleaver is part of the SCPPM encoder and is not related to the channel interleaver.

3.8.4 ACCUMULATOR

3.8.4.1 Interleaved convolutional codewords shall enter an accumulator, a rate-one code with transfer function $1 / (1 + D)$, as shown in figure 3-9.

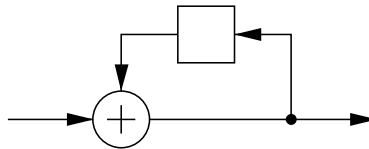

Figure 3-9: The Accumulator

3.8.4.2 The accumulator shall be initialized to the ‘all zeroes’ state prior to encoding each interleaved convolutional codeword as follows: For the i^{th} codeword, the j^{th} output of the accumulator is given by

$$n_j^i = \begin{cases} l_j^i, & \text{if } j = 0 \\ n_{j-1}^i \oplus l_j^i, & \text{if } 1 \leq j < 15120 \end{cases}.$$

3.8.5 PPM SYMBOL MAPPER

The output code symbols from the accumulator shall be mapped to M -ary PPM symbols, where $M \in \{4,8,16,32,64,128,256\}$ is a managed parameter, as follows:

- a) Every $m = \log_2 M$ binary code symbols shall be grouped to form one PPM symbol, which is an integer in $\{0, 1, \dots, M - 1\}$.

NOTE – The output is the sequence of SCPPM codewords q^0, q^1, \dots, q^{C-1} . Each codeword consists of

$$S = \frac{15120}{m}$$

PPM symbols.

- b) For $j \in \{0, 1, \dots, S - 1\}$, the j^{th} PPM symbol of the i^{th} SCPPM codeword shall be

$$q_j^i = \sum_{a=0}^{m-1} 2^{m-a-1} \cdot n_{mj+a}^i.$$

NOTE – In this way, the PPM symbol is simply the integer value corresponding to each grouping of m binary code symbols.

For example, when $M = 16$, an accumulator output of

$$n_0^i, n_1^i, n_2^i, n_3^i, n_4^i, n_5^i, n_6^i, n_7^i, \dots = \underbrace{1, 1, 0, 1, 0, 1, 0, 1, \dots}_{13} \underbrace{0, 1, 0, 1, \dots}_5$$

would correspond to PPM symbols $q_0^i, q_1^i, \dots = 13, 5, \dots$

Since 15120 is a multiple of $m = \log_2 M$, there are no leftover code symbols in the groupings.

3.9 CHANNEL INTERLEAVER

3.9.1 GENERAL

The sequence of PPM symbols \hat{q} shall be channel interleaved with a convolutional interleaver, as shown in figure 3-10 and described herein.

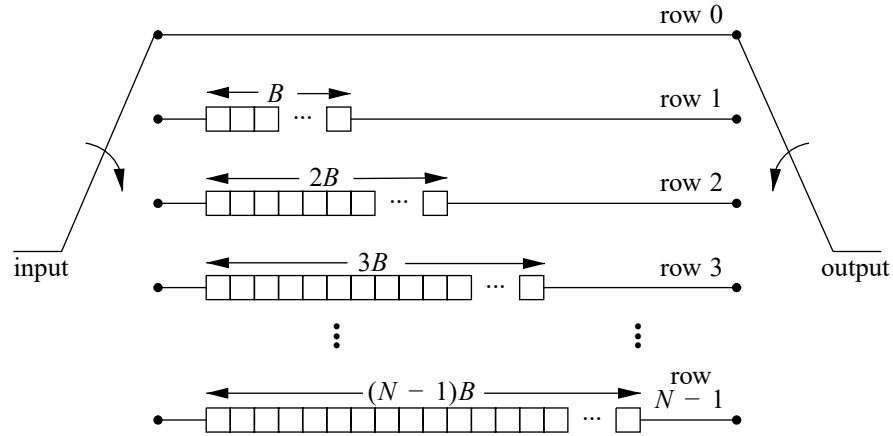

Figure 3-10: Convolutional Channel Interleaver

3.9.2 CHANNEL INTERLEAVER INPUT NOTATION

The sequence of SCPPM codewords $\mathbf{q} = \mathbf{q}^0, \mathbf{q}^1, \dots, \mathbf{q}^{C-1}$ shall be a vector of vectors that can be viewed as a single vector of PPM symbols

$$\hat{\mathbf{q}} = \hat{q}_0, \hat{q}_1, \dots, \hat{q}_{CS-1},$$

where for $i \in \{0, 1, \dots, C-1\}$ and $j \in \{0, 1, \dots, S-1\}$,

$$\hat{q}_{iS+j} = q_j^i.$$

3.9.3 CHANNEL INTERLEAVER PARAMETERS

Parameters N and B are managed and shall be chosen so that BN is a multiple of S , which in turn is a multiple of N .

NOTE – The interleaver has N rows, with the i^{th} row containing a shift register of length iB , meaning that it holds iB PPM symbols.

3.9.4 CHANNEL INTERLEAVER INITIALIZATION

Prior to channel interleaving, the shift registers shown in figure 3-10 may be in any state.

3.9.5 CHANNEL INTERLEAVER OPERATION

3.9.5.1 Channel Interleaver Arm Positions

3.9.5.1.1 The input PPM symbols \hat{q} shall be demultiplexed into the N rows, sequentially and in circular fashion, beginning with row 0.

3.9.5.1.2 The outputs of the N shift registers shall be multiplexed, sequentially and in circular fashion, beginning with row 0.

3.9.5.1.3 During each step of the operation of the channel interleaver, the demultiplexer arm shall be positioned at the same row as the multiplexer arm.

3.9.5.1.4 The i^{th} interleaver output is

$$\hat{r}_i = \hat{q}_{\sigma(i)},$$

where $\sigma(i)$ is defined recursively by

$$\sigma(i) = \begin{cases} i, & \text{if } i \bmod N = 0 \\ \sigma(i-1) - NB + 1, & \text{otherwise} \end{cases}.$$

NOTES

- 1 Negative values of $\sigma(i)$ refer to initial interleaver register contents, and values of $\sigma(i)$ greater than $CS - 1$ refer to terminal register contents. In these cases, \hat{r}_i may be any value.
- 2 For example, when $N = 4$ and $B = 1$, the input $\hat{q}_0, \hat{q}_1, \hat{q}_2, \dots$ will produce an interleaver output of

$$\hat{r}_0, \hat{r}_1, \hat{r}_2, \hat{r}_3, \hat{r}_4, \hat{r}_5, \hat{r}_6, \hat{r}_7, \hat{r}_8, \hat{r}_9, \hat{r}_{10}, \dots = \hat{q}_0, \hat{q}_{-3}, \hat{q}_{-6}, \hat{q}_{-9}, \hat{q}_4, \hat{q}_1, \hat{q}_{-2}, \hat{q}_{-5}, \hat{q}_8, \hat{q}_5, \hat{q}_2, \dots$$

3.9.5.2 Completion of the Channel Interleaver Operations

3.9.5.2.1 After the last symbol, \hat{q}_{CS-1} , is input, the interleaver shall be operated another $BN(N - 1)$ steps before \hat{q}_{CS-1} appears at the output.

NOTE – Thus the output contains $BN(N - 1)$ more symbols than the input. This output of the channel interleaver is

$$\hat{r} = \hat{r}_0, \hat{r}_1, \dots, \hat{r}_{SC+BN(N-1)-1}.$$

3.9.5.2.2 For $i \in \{0, 1, \dots, SC + BN(N-1) - 1\}$, the i^{th} interleaver output shall be as defined in 3.9.5.1.

3.9.5.3 Reindexing Channel Interleaver Output to Form Interleaved Codewords

The sequence \hat{r} may be reindexed into $R = C + BN(N-1) / S$ blocks each containing S symbols:

$$\mathbf{r}^0, \mathbf{r}^1, \dots, \mathbf{r}^{R-1},$$

where for $i \in \{0, 1, \dots, R-1\}$ the i^{th} block is denoted $\mathbf{r}^i = r_0^i, r_1^i, \dots, r_{S-1}^i$, and for $j \in \{0, 1, \dots, S-1\}$,

$$r_j^i = \hat{r}_{iS+j}.$$

NOTES

- 1 Each \mathbf{r}^i is called an interleaved codeword (notwithstanding the fact that it contains symbols from many different SCPPM codewords), because it contains S M -ary PPM symbols.
- 2 Since $BN(N-1)$ is a multiple of S , there are no leftover PPM symbols in the last block.

3.10 CODEWORD SYNCHRONIZATION MARKER

3.10.1 DESCRIPTION

A CSM of W PPM symbols shall be prepended to each interleaved SCPPM codeword. After CSM attachment, the j^{th} PPM symbol of the i^{th} interleaved codeword is:

$$\hat{s}_j^i = \begin{cases} w_j, & \text{if } 0 \leq j < W \\ r_{j-W}^i, & \text{if } W \leq j < S + W \end{cases}.$$

NOTE – The sequence of CSM+interleaved-codewords is $\hat{\mathbf{s}} = \hat{\mathbf{s}}^0, \hat{\mathbf{s}}^1, \dots, \hat{\mathbf{s}}^{R-1}$.

3.10.2 CSM SPECIFICATION

3.10.2.1 For $M \geq 8$, W shall be 16; for $M = 4$, W shall be 24. The CSM shall be:

$$\mathbf{w} = \begin{cases} (0, 3, 1, 2, 1, 3, 2, 0, 0, 3, 2, 1, 0, 2, 1, 3, 1, 0, 3, 2, 3, 2, 1, 0) & \text{if } M = 4 \\ (0, 3, 1, 2, 5, 4, 7, 6, 6, 7, 4, 5, 2, 1, 3, 0) & \text{if } M = 8 \\ (0, 2, 7, 14, 1, 2, 15, 5, 8, 4, 10, 2, 14, 3, 14, 11) & \text{if } M \geq 16 \end{cases} .$$

3.10.2.2 This sequence shall be reindexed in PPM symbols as $\mathbf{s} = s_0, s_1, \dots, s_{R(S+W)-1}$, where

$$s_{iS+j} = \hat{s}_j^i .$$

3.11 REPEAT

Each PPM symbol shall be repeated so that it appears q_d times, where the repeat factor $q_d \in \{1, 2, 3, 4, 8, 16, 32\}$ is a managed parameter, as follows: For $j \in \{0, 1, \dots, q_d R(S+W) - 1\}$, the j^{th} symbol at the output of the repeater is

$$t_j = s_{\lfloor j/q_d \rfloor} \bmod M ,$$

where $\lfloor x \rfloor$ denotes the integer part of x .

3.12 SLOT MAPPER

For $j \in \{0, 1, \dots, q_d R(S+W) - 1\}$, the j^{th} repeated PPM symbol $t_j \in \{0, 1, \dots, M-1\}$ shall be mapped to a binary vector of length M ,

$$\mathbf{u}_j = u_{j,0}, u_{j,1}, \dots, u_{j,M-1},$$

where for $i \in \{0, 1, \dots, M-1\}$,

$$u_{j,i} = \begin{cases} 1, & \text{if } i = t_j \\ 0, & \text{otherwise} \end{cases} .$$

NOTE – Each \mathbf{u}_j contains $M-1$ ‘zeroes’ and one ‘one’.

3.13 GUARD SLOT INSERTION

After each set of M slots \mathbf{u}_j , $M/4$ guard slots shall be inserted, as shown in figure 3-11. The result is the slot sequence $\mathbf{v} = \mathbf{v}_0, \mathbf{v}_1, \dots, \mathbf{v}_{q_d R(S+W)-1}$, where each \mathbf{v}_j is a vector of length $5M/4$, and

$$\mathbf{v}_{j,i} = \begin{cases} \mathbf{u}_{j,i}, & \text{if } 0 \leq i < M \\ 0, & \text{if } M \leq i < 5M/4 \end{cases}$$

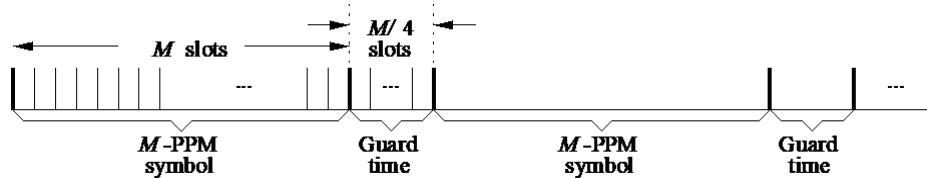

Figure 3-11: Guard Slot Insertion

3.14 TRANSFER FRAME VALIDATION

3.14.1 OVERVIEW

The receiving end of the telemetry transmission obtains slot and symbol synchronization, and then uses the CSMs to obtain codeword synchronization. The symbols are deinterleaved, and SCPPM codewords are decoded and derandomized. The resulting sequence of SMTFs are synchronized by identifying the ASMs, which are removed, yielding the transfer frames.

3.14.2 QUALITY INDICATOR

A transfer frame shall be marked valid if it is recovered from one or more correctly decoded SCPPM codewords; a transfer frame shall be marked invalid if it is recovered from one or more incorrectly decoded codewords.

3.14.3 OPTIONAL FRAME ERROR CONTROL FIELD IN TRANSFER FRAME

The Frame Error Control Field (FECEF) defined in reference [1], [2], or [8] is optional, and the system designer may choose to use it for additional frame validation in the Data Link Protocol Sublayer.

3.15 SEQUENCE INDICATOR

A Sequence Indicator shall be 'zero' when a transfer frame is the direct successor of the previous one, and 'one' when a gap has been detected.

4 HPE BEACON AND OPTIONAL ACCOMPANYING DATA TRANSMISSION SIGNALING

4.1 OVERVIEW

The telemetry and beacon signals operate simultaneously and in opposite directions on the link. The beacon signal may or may not include data transmission. When the beacon signal does not carry data, it is a simple square wave, as described in reference [3]. When the beacon signal carries data, the Coding and Synchronization Sublayer takes AOS or USLP fixed-length transfer frames (reference [2] or [8]) as input and produces a binary vector indicating the positions of pulsed slots at the output. The functional blocks of the architecture are shown in figure 4-1, along with the notation used in the following sections that defines these functions mathematically. It should be understood that the functions need not be implemented explicitly as defined here; any implementation producing the proper pattern of pulsed slots complies with the standard.

NOTES

- 1 The specification given here is intended to provide a beacon and optional low-data-rate transmission. This specification is compatible with higher data rates, by splitting each signal slot into narrower slots, which may be independently modulated at a higher rate.
- 2 In RF communications, the operations of a spacecraft receiver are such that it is convenient to require uplink transmissions to consist, first of an unmodulated carrier, and then a carrier modulated with an acquisition sequence, prior to sending data. For this reason, the RF uplink synchronization and coding standard (reference [6]) specifies a Physical Layer Operations Procedure (PLOP) that details the manner and order in which these types of signals are to be transmitted, in order to establish a physical connection between the transmitter and receiver.

By contrast, in optical communications, the spacecraft receiver does not require transmission of an unmodulated carrier or an acquisition sequence. For this reason, this Recommended Standard does not specify a PLOP, and in this respect, the operation of the AOS/USLP transfer frame signaling is similar to the telemetry signaling.

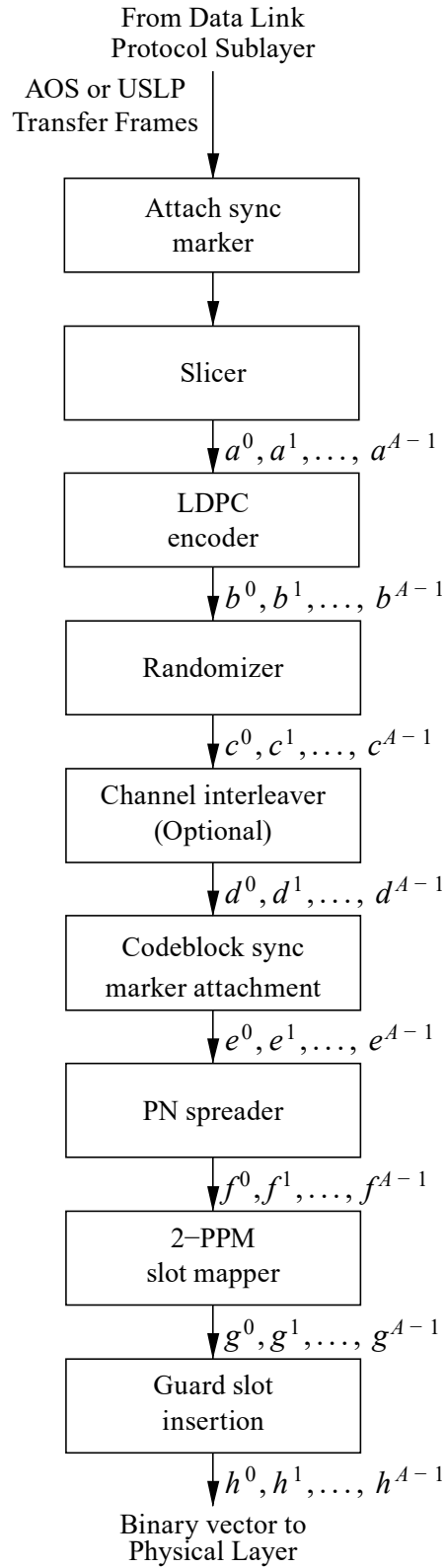

Figure 4-1: Functional Diagram for AOS/USLP Transfer Frame Signaling

4.2 INPUT TO CODING AND SYNCHRONIZATION SUBLAYER

4.2.1 AOS/USLP TRANSFER FRAME

The input to the Coding and Synchronization Sublayer shall be an AOS or USLP transfer frame. The structures of the AOS and USLP transfer frames are defined in references [2] and [8], respectively.

4.2.2 AOS/USLP TRANSFER FRAME LENGTH

The length of the AOS or USLP transfer frames shall be a fixed length, controlled by a managed parameter.

4.3 ATTACHED SYNCHRONIZATION MARKER

ASMs shall be inserted before each AOS/USLP transfer frame, in the manner described in 3.3, to form SMTFs.

NOTE – The ASM together with the AOS/USLP transfer frame is called an SMTF. The SMTFs have a fixed length, because the AOS/USLP transfer frame has a fixed length, controlled by a managed parameter.

4.4 SLICER

4.4.1 SLICER LENGTH

The SMTFs shall be sliced into blocks of length $k \in \{64,256,1024\}$, using the method specified in 3.4. k is a managed parameter.

NOTE – The sliced stream of data forms a contiguous sequence of A binary slices (vectors), $\mathbf{a}^0, \mathbf{a}^1, \dots, \mathbf{a}^{A-1}$. Each slice is k binary digits in length. For $i \in \{0, 1, \dots, A-1\}$, the i^{th} slice is denoted

$$\mathbf{a}^i = a_0^i, a_1^i, \dots, a_{k-1}^i,$$

where $a_j^i \in \{0,1\}$ is the j^{th} bit of the i^{th} slice.

4.4.2 ZERO FILL

At transmission closure, the slicer output shall be zero-filled with the minimum number of ‘zeroes’ so that its length is a multiple of k .

4.5 LDPC ENCODER

Each information block \mathbf{a}^i shall be encoded using the (128, 64) or (512, 256) binary LDPC code defined in section 4 of reference [6], or the (2048, 1024) LDPC code defined in section 7 of reference [7].

NOTE – For $i \in \{0, 1, \dots, A-1\}$, the $n = 2k$ binary symbols of the i^{th} LDPC-encoded transfer frame are denoted

$$\mathbf{b}^i = b_0^i, b_1^i, \dots, b_{n-1}^i,$$

where $b_j^i \in \{0, 1\}$ is the j^{th} binary digit of the i^{th} codeword.

4.6 PSEUDO-RANDOMIZER

4.6.1 APPLICATION OF PSEUDO-RANDOMIZER

Each codeword \mathbf{b}^i shall be pseudo-randomized by performing the digit-wise modulo-2 addition with a binary pseudo-random sequence p_0, p_1, p_2, \dots as follows: For $i \in \{0, 1, \dots, A-1\}$, the i^{th} pseudo-randomized codeword is $\mathbf{c}^i = c_0, c_1, \dots, c_{n-1}$ and for $j \in \{0, 1, \dots, n-1\}$, the j^{th} binary symbol is given by

$$c_j^i = b_j^i \oplus p_j,$$

where \oplus represents modulo-2 addition.

4.6.2 SEQUENCE SPECIFICATION

The pseudo-random sequence shall be as defined in 3.5.2.

4.6.3 SEQUENCE INITIALIZATION

The shift register shall be initialized to the ‘all ones’ state at the beginning of each codeword.

4.7 CHANNEL INTERLEAVER

4.7.1 A channel interleaver may be used with AOS transfer frame signaling.

NOTE – Usage is controlled by a managed parameter.

4.7.2 If a channel interleaver is used, it shall operate on pseudo-randomized codewords and be as described in 3.9.

4.7.3 For the purposes of the channel interleaver, the parameter S in 3.9 should be understood to refer to the number of symbols in each AOS transfer frame pseudo-randomized codeword, $S = n = 2k$.

4.7.4 The number of rows in the AOS transfer frame channel interleaver may be denoted N_u , and the shift register increment in the AOS transfer frame channel interleaver may be denoted B_u .

NOTE – The output of the channel interleaver is $\mathbf{d}^0, \dots, \mathbf{d}^{A-1}$.

4.8 CODEWORD SYNCHRONIZATION MARKER

When the (128, 64) or (512, 256) LDPC code is used, a CSM of 16 binary symbols shall be prepended to each pseudo-randomized (and optionally interleaved) codeword. The CSM shall be EB90, in hexadecimal, which is the same marker defined in subsection 5.2.2 of reference [6]. When the (2048, 2014) LDPC code is used, a CSM of 64 binary symbols shall be prepended. The CSM in that case shall be 034776C7272895B0, in hexadecimal, which is the same marker defined in subsection 9.3.4 of reference [7].

NOTE – A CSM together with a pseudo-randomized codeword is called an SMCW. When a 16-symbol CSM is used, the i^{th} SMCW is denoted

$$\mathbf{e}^i = e_0^i, e_1^i, \dots, e_{n+15}^i.$$

4.9 PN SPREADER

Each SMCW shall be PN-spread by a factor of q_u , $q_u \in \{1, 2, 3, 4, 8, 16, 32, 64\}$, by repeating each binary symbol so that it appears q_u times and digit-wise adding it to a binary PN-like sequence $\mathbf{p} = p_0, p_1, \dots, p_{q_u-1}$, as follows: for $i \in \{0, 1, \dots, A-1\}$, the i^{th} PN-spread SMCW is \mathbf{f}^i , and for $j \in \{0, 1, \dots, (n+16)q_u-1\}$, the j^{th} binary symbol is given by

$$f_j^i = e_{j \bmod q_u}^i \oplus p_{j \bmod q_u},$$

where p_0, p_1, p_2, \dots are the binary digits of the PN sequence given in table 4-1 and where $\lfloor x \rfloor$ is the integer part of x .

Table 4-1: PN Sequence

q_u	p
1	0
2	01
3	011
4	0110
8	0111 0010
16	0111 0011 0110 1000
32	0111 0101 0001 1110 1101 1100 1001 0000
64	0100 1110 1101 0011 1010 0001 0101 1101 0110 0101 1100 1100 1100 1111 0000 1000

4.10 2-PPM SLOT MAPPER

4.10.1 For $i \in \{0, 1, \dots, A-1\}$, the i^{th} PN spread SMCW shall be a sequence of binary symbols denoted

$$\mathbf{f}^i = f_0^i, f_1^i, \dots, f_{(n+16)q_u-1}^i.$$

4.10.2 To modulate with 2-PPM, each binary symbol f_j^i shall be mapped to a vector of length 2 by

$$\mathbf{g}_j^i = (g_{j,0}^i, g_{j,1}^i) = \begin{cases} (1,0), & \text{if } f_j^i = 0 \\ (0,1), & \text{otherwise} \end{cases};$$

the length $2(n+16)q_u$ sequence of slots for the i^{th} SMCW is denoted

$$\mathbf{g}^i = g_{0,0}^i, g_{0,1}^i, g_{1,0}^i, g_{1,1}^i, \dots, g_{(n+16)q_u-1,0}^i, g_{(n+16)q_u-1,1}^i.$$

4.11 GUARD SLOT INSERTION

After each 2-PPM symbol comprising two slots, a guard time of two slots shall be inserted. For $i \in \{0, 1, \dots, A-1\}$, the result for the i^{th} SMCW in the slot sequence is denoted

$$\mathbf{h}^i = g_{0,0}^i, g_{0,1}^i, 0, 0, g_{1,0}^i, g_{1,1}^i, 0, 0, \dots, g_{(n+16)q_u-1,0}^i, g_{(n+16)q_u-1,1}^i, 0, 0.$$

4.12 AOS/USLP TRANSFER FRAME VALIDATION AND SEQUENCE INDICATOR

4.12.1 At the receiving end AOS/USLP Transfer Frames shall be validated using the same procedure defined in 3.14.

4.12.2 At the receiving end a Sequence Indicator shall be computed using the same procedure defined in 3.15.

5 MANAGED PARAMETERS

5.1 OVERVIEW

Some parameters associated with synchronization and channel coding are handled by management rather than by an inline communications protocol. The managed parameters are those that tend to be static for long periods of time, and whose change generally signifies a major reconfiguration of the synchronization and channel coding systems associated with a particular mission. Through the use of a management system, management conveys the required information to the channel coding and synchronization systems.

In this section, the managed parameters used by channel coding and synchronization systems are listed. These parameters are defined in an abstract sense and are not intended to imply any particular implementation of a management system.

5.2 MANAGED PARAMETERS FOR TELEMETRY SIGNALING

The managed parameters for a HPE telemetry signaling shall be those specified in table 5-1.

Table 5-1: Managed Parameters for HPE Telemetry Signaling

Managed Parameter	Allowed Values
TM/AOS/USLP transfer frame length (octets)	Integer (max 65536)
PPM order, M	4, 8, 16, 32, 64, 128, 256
Code rate, r	1/3, 1/2, 2/3
Number of rows in channel interleaver, N	BN shall be a multiple of S , which in turn shall be a multiple of N .
Shift register length increment in channel interleaver, B	
Repeat factor, q_d	1, 2, 3, 4, 8, 16, 32

5.3 MANAGED PARAMETERS FOR AOS/USLP TRANSFER FRAME SIGNALING

The managed parameters for a HPE AOS/USLP transfer frame signaling shall be those specified in table 5-2.

Table 5-2: Managed Parameters for HPE AOS/USLP Transfer Frame Signaling

Managed Parameter	Allowed Values
AOS/USLP transfer frame length (octets)	Integer (max 65536)
Input block length, k	64, 256, 1024
PN spreading factor, q_u	1, 2, 3, 4, 8, 16, 32, 64
Channel interleaver	Used, not used
Number of rows in channel interleaver, N_u	$B_u N_u$ shall be a multiple of 128, which in turn shall be a multiple of N_u .
Shift register length increment in channel interleaver, B_u	

ANNEX A

PROTOCOL IMPLEMENTATION CONFORMANCE STATEMENT PROFORMA

(NORMATIVE)

A1 INTRODUCTION

A1.1 OVERVIEW

This annex provides the Protocol Implementation Conformance Statement (PICS) Requirements List (RL) for an implementation of Optical Communications Coding and Synchronization, (CCSDS 142.0-B-1). The PICS for an implementation is generated by completing the RL in accordance with the instructions below. An implementation claiming conformance must satisfy the mandatory requirements referenced in the RL.

The RL support column in this annex is blank. An implementation's completed RL is called the PICS. The PICS states which capabilities and options have been implemented. The following can use the PICS:

- the implementer, as a checklist to reduce the risk of failure to conform to the standard through oversight;
- a supplier or potential acquirer of the implementation, as a detailed indication of the capabilities of the implementation, stated relative to the common basis for understanding provided by the standard PICS proforma;
- a user or potential user of the implementation, as a basis for initially checking the possibility of interworking with another implementation (it should be noted that, while interworking can never be guaranteed, failure to interwork can often be predicted from incompatible PICSes);
- a tester, as the basis for selecting appropriate tests against which to assess the claim for conformance of the implementation.

A1.2 ABBREVIATIONS AND CONVENTIONS

The RL consists of information in tabular form. The status of features is indicated using the abbreviations and conventions described below.

Item Column

The item column contains sequential numbers for items in the table.

Description Column

The description column contains a brief description of the item. It implicitly means ‘Is this item supported by the implementation?’

Reference Column

The reference column indicates the relevant subsection of *Optical Communications Coding and Synchronization*, CCSDS 142.0-B-1 (this document).

Status Column

The status column uses the following notations:

M	mandatory.
O	optional.
C:<status>	indicates that the status applies for the given subordinate item when the parent item is supported, and is not applicable otherwise.
1+	One or more of the allowed values must be supported
N/A	not applicable.

Support Column Symbols

The support column is to be used by the implementer to state whether a feature is supported by entering Y, N, or N/A, indicating:

Y	Yes, supported by the implementation.
N	No, not supported by the implementation.
N/A	Not applicable.

The support column should also be used, when appropriate, to enter values supported for a given capability.

A1.3 INSTRUCTIONS FOR COMPLETING THE RL

An implementer shows the extent of compliance to the Recommended Standard by completing the RL; that is, the state of compliance with all mandatory requirements and the options supported are shown. The resulting completed RL is called an PICS. The implementer shall complete the RL by entering appropriate responses in the support or values supported column, using the notation described in A1.2. If a conditional requirement is inapplicable, N/A should be used. If a mandatory requirement is not satisfied, exception information must be supplied by entering a reference X_i , where i is a unique identifier, to an accompanying rationale for the noncompliance.

A2 PICS PROFORMA FOR OPTICAL COMMUNICATIONS CODING AND SYNCHRONIZATION (CCSDS 142.0-B-1)

A2.1 GENERAL INFORMATION

A2.1.1 Identification of PICS

Date of Statement (DD/MM/YYYY)	
PICS serial number	
System Conformance statement cross-reference	

A2.1.2 Identification of Implementation Under Test (IUT)

Implementation Name	
Implementation Version	
Special Configuration	
Other Information	

A2.1.3 Identification of Supplier

Supplier	
Contact Point for Queries	
Implementation Name(s) and Versions	
Other information necessary for full identification, for example, name(s) and version(s) for machines and/or operating systems; System Name(s)	

A2.1.4 Identification of Specification

CCSDS 142.0-B-1	
Have any exceptions been required? NOTE – A YES answer means that the implementation does not conform to the Recommended Standard. Non-supported mandatory capabilities are to be identified in the PICS, with an explanation of why the implementation is nonconforming.	Yes [] No []

CCSDS RECOMMENDED STANDARD FOR
OPTICAL COMMUNICATIONS CODING AND SYNCHRONIZATION

A2.1.5 Requirements List

HPE Telemetry signaling:

Item	Description	Reference	Status	Values Allowed	Item Supported or Values Supported
HPE-1	CCSDS transfer frames	3.2	M	N/A	
HPE-2	ASM	3.3	M	N/A	
HPE-3	Slicer	3.4	M	N/A	
HPE-4	Pseudo-Randomizer	3.5	M	N/A	
HPE-5	CRC attachment	3.6	M	N/A	
HPE-6	Termination	3.7	M	N/A	
HPE-7	SCPPM encoder	3.8	M	N/A	
HPE-8	Channel interleaver	3.9	M	N/A	
HPE-9	(N , B) parameters for channel interleaver	3.9.3	1+	(See table 5-1.)	
HPE-10	Codeword synchronization marker	3.10	M	N/A	
HPE-11	Repeat factor	3.11	1+	1, 2, 3, 4, 8, 16, 32	
HPE-12	Slot mapper	3.12	M	N/A	
HPE-13	Guard slot insertion	3.13	M	N/A	
HPE-14	Transfer Frame validation	3.14	M	N/A	

CCSDS RECOMMENDED STANDARD FOR
OPTICAL COMMUNICATIONS CODING AND SYNCHRONIZATION

SCPPM encoder features:

Item	Description	Reference	Status	Values Allowed	Item Supported or Values Supported
HPE-14	Convolutional code polynomial	3.8.2.1	M	N/A	
HPE-15	Initialization	3.8.2.2	M	N/A	
HPE-16	Convolutional code rate	3.8.2.3	1+	1/3, 1/2, 2/3	
HPE-17	Puncturing	3.8.2.3	M	N/A	
HPE-18	Code Interleaver	3.8.3	M	N/A	
HPE-19	Accumulator	3.8.4	M	N/A	
HPE-20	PPM order	3.8.5	1+	4, 8, 16, 32, 64, 128, 256	
HPE-21	PPM symbol mapper	3.8.5	M	N/A	

CCSDS RECOMMENDED STANDARD FOR
OPTICAL COMMUNICATIONS CODING AND SYNCHRONIZATION

HPE beacon and optional AOS Transfer Frame signaling:

Item	Description	Reference	Status	Values Allowed	Item Supported or Values Supported
HPE-22.1	AOS/USLP Transfer Frame	4.2	C:M	N/A	
HPE-22.2	Attached Synchronization Marker	4.3	C:M	N/A	
HPE-22.3	Slicer	4.4	C:M	N/A	
HPE-22.4	LDPC Encoder input block length, k	4.5	C:1+	64, 256, 1024	
HPE-22.5	Pseudo-randomizer	4.6	C:M	N/A	
HPE-22.6	Channel interleaver	4.7	C:O	N/A	
HPE-22.6.1	(N, B) parameters for channel interleaver	4.7	C:C:1+	See Table 5.2	
HPE-22.7	Codeword sync marker	4.8	M	N/A	
HPE-22.8	PN spreading factor	4.9	1+	1, 2, 3, 4, 8, 16, 32, 64	
HPE-22.9	2-PPM slot mapper	4.10	M	N/A	
HPE-22.10	Guard slot insertion	4.11	M	N/A	

ANNEX B

SERVICE

(NORMATIVE)

B1 OVERVIEW

B1.1 INTRODUCTION

This annex provides service definition in the form of primitives, which present an abstract model of the logical exchange of data and control information between the service provider and the service user. The definitions of primitives are independent of specific implementation approaches.

The parameters of the primitives are specified in an abstract sense and specify the information to be made available to the user of the primitives. The way in which a specific implementation makes this information available is not constrained by this specification. In addition to the parameters specified in this annex, an implementation can provide other parameters to the service user (e.g., parameters for controlling the service, monitoring performance, facilitating diagnosis, and so on).

B1.2 OVERVIEW OF THE SERVICE

For telemetry signaling, this Recommended Standard provides unidirectional (one way) transfer of a sequence of CCSDS transfer frames (see, e.g., references [1] and [2]) at a constant data rate over a Physical Channel across a space link, using one of a number of specified channel coding and modulation methods.

For AOS transfer frame signaling, the Recommended Standard provides unidirectional (one way) transfer of a sequence of fixed-length AOS transfer frames over a Physical Channel across a space link using a specified channel coding and modulation method.

B2 TELEMETRY SERVICE PARAMETERS

B2.1 OPTICAL TELEMETRY FRAME

B2.1.1 The Optical Telemetry (OTM) Frame parameter is the service data unit of this service and shall be a CCSDS transfer frame as defined in reference [1] or [2].

B2.1.2 The length of any transfer frame transferred on a Physical Channel shall be established by management.

B2.2 QUALITY INDICATOR

The Quality Indicator parameter shall be used to notify the user at the receiving end of the service that the received transfer frame was not able to be successfully decoded.

B2.3 SEQUENCE INDICATOR

The Sequence Indicator parameter shall be used to notify the user at the receiving end of the service that one or more transfer frames of the Physical Channel have been lost as the result of a loss of frame synchronization.

B3 TELEMETRY SERVICE PRIMITIVES

B3.1 GENERAL

B3.1.1 The service primitives associated with this service are

- a) OTM ChannelAccess.request; and
- b) OTM ChannelAccess.indication.

B3.1.2 The OTM ChannelAccess.request primitive shall be passed from the service user at the sending end to the service provider to request that a Frame be transferred through the Physical Channel to the user at the receiving end.

B3.1.3 The OTM ChannelAccess.indication shall be passed from the service provider to the service user at the receiving end to deliver a Frame.

B3.2 OTM CHANNELACCESS.REQUEST

B3.2.1 Function

The OTM ChannelAccess.request primitive is the service request primitive for this service.

B3.2.2 Semantics

The OTM ChannelAccess.request primitive shall provide a parameter as follows:

OTM ChannelAccess.request (OTM Frame)

B3.2.3 When Generated

The ChannelAccess.request primitive shall be passed to the service provider to request it to process and send the Frame.

B3.2.4 Effect on Receipt

Receipt of the OTM ChannelAccess.request primitive shall cause the service provider to perform the functions described in section 3 and to transfer the resulting pulsed slot sequence.

B3.3 OTM CHANNELACCESS.INDICATION

B3.3.1 Function

The OTM ChannelAccess.indication primitive is the service indication primitive for this service.

B3.3.2 Semantics

The OTM ChannelAccess.indication primitive shall provide parameters as follows:

OTM ChannelAccess.indication (OTM Frame, Quality Indicator, Sequence Indicator)

B3.3.3 When Generated

The OTM ChannelAccess.indication primitive shall be passed from the service provider to the service user to deliver a Frame.

B3.3.4 Effect on Receipt

The effect of receipt of the OTM ChannelAccess.indication primitive by the service user is undefined.

B4 AOS/USLP TRANSFER FRAME SERVICE PARAMETER

The AOS/USLP Data Unit (ADU) frame parameter is the service data unit of this service, as defined in reference [2].

B5 AOS/USLP TRANSFER FRAME SERVICE PRIMITIVES

B5.1 GENERAL

B5.1.1 The service primitives associated with this service are

- a) ADU ChannelAccess.request; and
- b) ADU ChannelAccess.indication.

B5.1.2 The ADU ChannelAccess.request primitive shall be passed from the service user at the sending end to the service provider to request that a Frame be transferred through the Physical Channel to the user at the receiving end.

B5.1.3 The ADU ChannelAccess.indication shall be passed from the service provider to the service user at the receiving end to deliver a Frame.

B5.2 ADU CHANNELACCESS.REQUEST

B5.2.1 Function

The ADU ChannelAccess.request primitive is the service request primitive for this service.

B5.2.2 Semantics

The ADU ChannelAccess.request primitive shall provide a parameter as follows:

ADU ChannelAccess.request (ADU Frame)

B5.2.3 When Generated

The ADU ChannelAccess.request primitive shall be passed to the service provider at the sending end to request it to process and send the ADU Frame.

B5.2.4 Effect on Receipt

Receipt of the ADU ChannelAccess.request primitive shall cause the service provider to perform the functions described in section 4 and to transfer the resulting pulsed slot sequence.

B5.3 ADU CHANNELACCESS.INDICATION

B5.3.1 Function

The ADU ChannelAccess.indication primitive is the service indication primitive for this service.

B5.3.2 Semantics

The ADU ChannelAccess.indication primitive shall provide parameters as follows:

ADU ChannelAccess.indication (ADU Frame, Quality Indicator, Sequence Indicator)

B5.3.3 When Generated

The ADU ChannelAccess.indication primitive shall be passed from the service provider to the service user to deliver an ADU Frame.

B5.3.4 Effect on Receipt

The effect of receipt of the ADU ChannelAccess.indication primitive by the service user is undefined.

ANNEX C

SECURITY, SANA, AND PATENT CONSIDERATIONS

(INFORMATIVE)

C1 SECURITY CONSIDERATIONS

C1.1 SECURITY BACKGROUND

It is assumed that security is provided by encryption, authentication methods, and access control to be performed at a layer above the Physical Layer and Coding and Synchronization Sublayer. Mission and service providers are expected to select from recommended security methods, suitable to the specific application profile. Specification of these security methods and other security provisions is outside the scope of this Recommended Standard.

The coding layer has the objective of delivering data with the minimum possible amount of residual errors. An LDPC, Reed-Solomon, or other code with CRC code needs to be used to ensure that residual errors are detected and the frame flagged. There is an extremely low probability of additional undetected errors that may escape this scrutiny. These errors may affect the encryption process in unpredictable ways, possibly affecting the decryption stage and producing data loss, but will not compromise the security of the data.

C1.2 SECURITY CONCERNS

Security concerns in the areas of data privacy, authentication, access control, availability of resources, and auditing are to be addressed in higher layers and are not related to this Recommended Standard.

C1.3 CONSEQUENCES OF NOT APPLYING SECURITY

There are no specific security measures prescribed for the coding layer. Therefore consequences of not applying security are only imputable to the lack of proper security measures in other layers. Residual undetected errors may produce additional data loss when the link carries encrypted data.

C2 SANA CONSIDERATIONS

The recommendations of this document do not require any action from SANA.

C3 PATENT CONSIDERATIONS

No patents are known to relate specifically to this Recommended Standard, and CCSDS member agencies have not filed any patents specific to this Recommended Standard. In particular, CCSDS is not aware of any patents that apply specifically to the (128,64) LDPC codes described in 4.5.

Attention is drawn to the possibility that some of the elements of this document may be the subject of patent rights other than those related to inventions of CCSDS member agencies. Implementers are cautioned that there are many patents filed on the general topics of channel coding and synchronization, including those related to LDPC codes and LDPC decoders.

ANNEX D

ABBREVIATIONS AND TERMS

(INFORMATIVE)

D1 OVERVIEW

This annex lists key acronyms and terms that are used throughout this Recommended Standard to describe synchronization and channel coding.

D2 ABBREVIATIONS

AOS	Advanced Orbiting Systems
ASM	attached synchronization marker
CRC	cyclic redundancy check
CSM	codeword synchronization marker
FECF	frame error control field
HPE	high photon efficiency
LDPC	low-density parity-check
MSB	most significant bit
OSI	Open System Interconnection
OTM	optical telemetry
PN	pseudo-random noise
PPM	pulse position modulation
SCPPM	serially concatenated convolutionally coded pulse position modulation
SMCW	synchronization-marked codeword
SMTF	synchronization-marked transfer frame
TM	telemetry
USLP	Unified Space Data Link Protocol

D3 TERMS

channel symbol: The unit of output of the innermost encoder.

code rate: The average ratio of the number of binary digits at the input of an encoder to the number of binary digits at its output.

codeword: Of an (n,k) block code, a sequence of n channel symbols that are produced by encoding a sequence of k information symbols.

Coding and Synchronization Sublayer: That sublayer of the Data Link Layer used by CCSDS space link protocols, which uses a prescribed coding technique to reliably transfer transfer frames through the potentially noisy Physical Layer.

constraint length: In convolutional coding, the number of consecutive input symbols needed to determine the value of the output symbols at any time.

convolutional code: A code in which a number of output symbols are produced for each input symbol. Each output symbol is a linear combination of the current input bit and some or all of the previous $k-1$ input bits, where k is the constraint length of the code.

slot measurement: Receiver estimate of the intensity of light, number of photons observed, or related statistic in a slot of the received transmission.

synchronization-marked transfer frame, SMTF: The data unit that consists of the ASM and the transfer frame.

ANNEX E

INFORMATIVE REFERENCES

- [E1] B. Moision and J. Hamkins. “Coded Modulation for the Deep-Space Optical Channel: Serially Concatenated Pulse-Position Modulation.” *IPN Progress Report 42-161* (May 15, 2005).

NOTE – Normative references are listed in 1.9.